



### NIPPON THOMPSON CO., LTD. (JAPAN)

Head Office : 7-17 Shiba 2-chome Minato-ku  
Tokyo 105-0014, Japan  
Phone : +81 (0)3-3448-5850  
Fax : +81 (0)3-3447-7637  
E-mail : ntt@ikonet.co.jp  
URL : http://www.ikonet.co.jp/eg/  
Plant : Gifu, Kamakura

### IKO INTERNATIONAL, INC. (U.S.A.)

#### East Coast Operations (Sales Head Office)

91 Walsh Drive  
Parsippany, NJ 07054  
U.S.A.  
Phone : +1 973-402-0254  
Toll Free : 1-800-922-0337  
Fax : +1 973-402-0441  
E-mail : eco@ikonet.co.jp

#### Midwest Operations

101 Mark Street Unit G,  
Wood Dale, IL 60191  
U.S.A.  
Phone : +1 630-766-6464  
Toll Free : 1-800-323-6694  
Fax : +1 630-766-6869  
E-mail : mwo@ikonet.co.jp

#### Minnesota Sales Office

1500 McAndrews Road West, Suite 210  
Burnsville, MN 55337  
U.S.A.  
Phone : +1 952-892-8415  
Toll Free : 1-800-323-6694  
Fax : +1 952-892-1722  
E-mail : mwo@ikonet.co.jp

#### West Coast Operations

9830 Norwalk Boulevard, Suite 198  
Santa Fe Springs, CA 90670  
U.S.A.  
Phone : +1 562-941-1019  
Toll Free : 1-800-252-3665  
Fax : +1 562-941-4027  
E-mail : wco@ikonet.co.jp

#### Silicon Valley Sales Office

1500 Wyatt Drive, Suite 10  
Santa Clara, CA 95054  
U.S.A.  
Phone : +1 408-492-0240  
Toll Free : 1-800-252-3665  
Fax : +1 408-492-0245  
E-mail : wco@ikonet.co.jp

#### Southeast Operations

2150 Boggs Road, Suite 100  
Duluth, GA 30096  
U.S.A.  
Phone : +1 770-418-1904  
Toll Free : 1-800-874-6445  
Fax : +1 770-418-9403  
E-mail : seo@ikonet.co.jp

#### Southwest Operations

8105 N. Beltline Road, Suite 130  
Irving, TX 75063  
U.S.A.  
Phone : +1 972-929-1515  
Toll Free : 1-800-295-7886  
Fax : +1 972-915-0060  
E-mail : swo@ikonet.co.jp

### IKO THOMPSON BEARINGS CANADA, INC.(CANADA)

731-2425 Matheson Boulevard East 7th floor  
Mississauga, Ontario L4W 5K4, Canada  
Phone : +1 905-361-2872  
Fax : +1 905-361-6401  
E-mail : itc@ikonet.co.jp

### IKO THOMPSON BRAZIL SERVICE CO.,LTD. (BRAZIL)

Rua Frei Caneca 1407, Condominio Edifício Barão  
de Monte Cedro, Cjs. 801/802, Consolação,  
01307-909, São Paulo, SP, Brazil  
Phone : +55 (0)11-2366-3033  
E-mail : itb@ikonet.co.jp

### NIPPON THOMPSON EUROPE B.V. (EUROPE)

#### The Netherlands (Sales Head Office)

Sheffieldstraat 35  
3047 AN Rotterdam  
The Netherlands  
Phone : +31 (0)10-462 68 68  
Fax : +31 (0)10-462 60 99  
E-mail : nte@ikonet.co.jp

#### Germany Branch

Mündelheimer Weg 54  
40472 Düsseldorf  
Germany  
Phone : +49 (0)211-41 40 61  
Fax : +49 (0)211-42 76 93  
E-mail : ntd@ikonet.co.jp

#### Regensburg Sales Office

Im Gewerbepark D 30  
93059 Regensburg  
Germany  
Phone : +49 (0)941-20 60 70  
Fax : +49 (0)941-20 60 719  
E-mail : ntdr@iko-nt.de

#### Neunkirchen Sales Office

Gruben Str. 95c  
66540 Neunkirchen  
Germany  
Phone : +49 (0)6821-99 98 60  
Fax : +49 (0)6821-99 98 626  
E-mail : ntdn@iko-nt.de

#### U.K. Branch

2 Vincent Avenue, Crownhill  
Milton Keynes, Bucks, MK8 0AB  
United Kingdom  
Phone : +44 (0)1908-566144  
Fax : +44 (0)1908-565458  
E-mail : sales@iko.co.uk

#### Spain Branch

Autovia Madrid-Barcelona, Km. 43,700  
Polig. Ind. AIDA - Nove A-8, Ofic. 2-1<sup>a</sup>  
19200 Azuqueca de Henares  
(Guadalajara) Spain  
Phone : +34 949-26 33 90  
Fax : +34 949-26 31 13  
E-mail : nts@ikonet.co.jp

#### France Branch

Bâtiment le Raphaël Paris Nord 2  
22 avenue des Nations  
BP54394 Villepinte  
95943 ROISSY C.D.G Cedex  
France  
Phone : +33 (0)1-48 16 57 39  
Fax : +33 (0)1-48 16 57 46  
E-mail : contact@iko-france.com

### IKO THOMPSON KOREA CO.,LTD. (KOREA)

2F, 111, Yeouigongwon-ro,  
Yeongdeungpo-gu, Seoul, Korea  
Phone : +82 (0)2-6337-5851  
Fax : +82 (0)2-6337-5852  
E-mail : itk@ikonet.co.jp

### IKO THOMPSON ASIA CO., LTD. (THAILAND)

1-7 Zuellig House, 3rd Floor  
Silom Road, Silom, Bangrak  
Bangkok 10500, Thailand  
Phone : +66 (0)2-637-5115  
Fax : +66 (0)2-637-5116  
E-mail : ita@ikonet.co.jp

### IKO-THOMPSON (SHANGHAI) LTD. (CHINA)

#### Shanghai (Sales Head Office)

1608-10 MetroPlaza No.555 LouShanGuan  
Road  
ChangNing District Shanghai  
People's Republic of China 200051  
Phone : +86 (0)21-3250-5525  
Fax : +86 (0)21-3250-5526  
E-mail : ntc@ikonet.co.jp

#### Beijing Branch

Room1506, Jingtai Tower,  
NO.24,Jianguomenwai Avenue,  
Chaoyang District, Beijing People's Republic of  
China 100022  
Phone : +86 (0)10-6515-7681  
Fax : +86 (0)10-6515-7681\*106  
E-mail : ntc@ikonet.co.jp

#### Guangzhou Branch

Room 834, Garden Tower, Garden Hotel  
368 Huanshi East Road, Yuexiu District,  
Guangzhou, Guangdong  
People's Republic of China 510064  
Phone : +86 (0)20-8384-0797  
Fax : +86 (0)20-8381-2863  
E-mail : ntc@ikonet.co.jp

#### Wuhan Branch

Room 2300, Truroll Plaza No.72 Wusheng  
Road, Qiao kou District, Wuhan, Hubei  
People's Republic of China 430033  
Phone : +86 (0)27-8556-1610  
Fax : +86 (0)27-8556-1630  
E-mail : ntc@ikonet.co.jp

#### Shenzhen Office

Room 420, Oriental Plaza,  
1072 Jianshe Road, Luohu District,  
Shenzhen, Guangdong  
People's Republic of China 518001  
Phone : +86 (0)755-2265-0553  
Fax : +86 (0)755-2298-0665  
E-mail : ntc@ikonet.co.jp

#### Ningbo Office

Room 3406, Zhongnongxin Building, No.181  
Zhongshan East Road, Haishu Ward, Ningbo,  
Zhejiang  
People's Republic of China 315000  
Phone : +86 (0)574-8718-9535  
Fax : +86 (0)574-8718-9533  
E-mail : ntc@ikonet.co.jp

#### Qingdao Office

2107 Block A, World Trade Center Building,  
No.230  
Changjiang Middle Road, Development Zone  
Qingdao  
People's Republic of China 266555  
Phone : +86 (0)532-8670-2246  
Fax : +86 (0)532-8670-2242  
E-mail : ntc@ikonet.co.jp

#### Shenyang Office

2-1203 Tower I, City Plaza Shenyang, No.206  
Nanjing North Street Heping District,  
Shenyang  
People's Republic of China 110001  
Phone : +86 (0)24-2334-2662  
Fax : +86 (0)24-2334-2442  
E-mail : ntc@ikonet.co.jp

# IKO

New

Precision Positioning Table

# TE...B

Now available with a longer stroke!



\* The specifications and dimensions of products in this catalog are subject to change without prior notice. \* When these products are exported, the exporter should confirm a forwarding country and a use, and, in case of falling under the customer's requirements, take necessary procedures such as export permission application. \* Although all data in this catalog has been carefully compiled to make the information as complete as possible, NIPPON THOMPSON CO., LTD. shall not be liable for any damages whatsoever, direct or indirect, based upon any information in this catalog. NIPPON THOMPSON CO., LTD. makes no warranty, either express or implied, including the implied warranty of merchantability or fitness for a particular purpose. \* Reproduction and conversion without permission are prohibited.



ISO 9001 & 14001 Quality system registration certificate



http://www.ikonet.co.jp/eg/

CAT-2948E

Printed in Japan ©2018.11 (AK)

NIPPON THOMPSON CO., LTD.

# Longer stroke products have been added to the TE series lineup of compact and lightweight precision positioning tables.

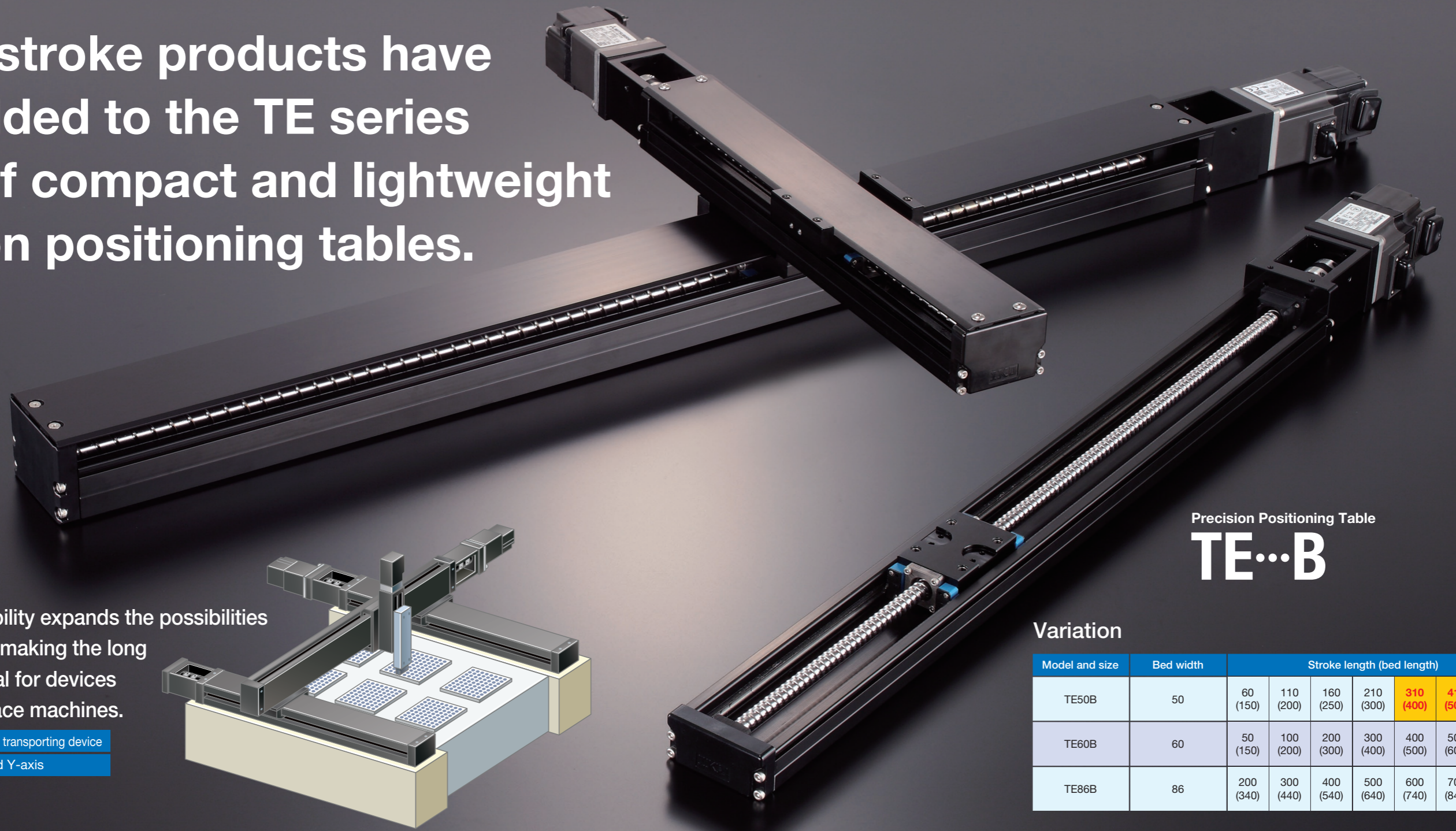

Precision Positioning Table  
**TE...B**

Longer stroke capability expands the possibilities for machine design, making the long stroke TE series ideal for devices such as pick and place machines.

Equipment used	Work piece transporting device
Location used	X-axis and Y-axis

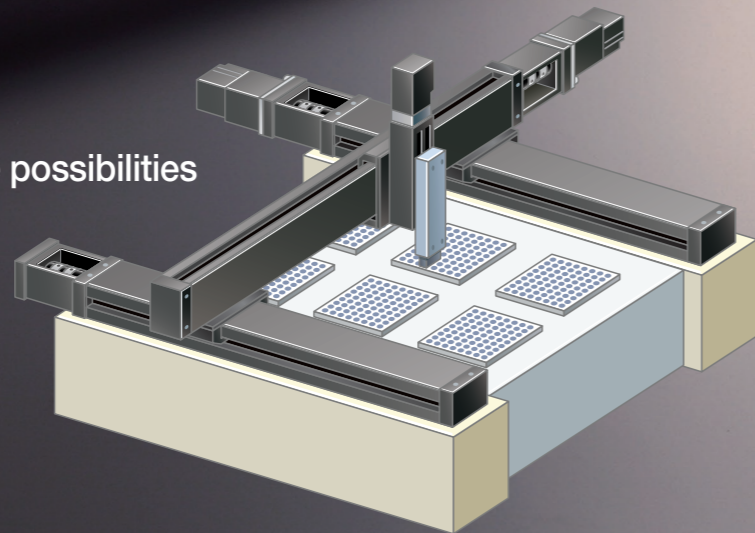

## Variation

Model and size	Bed width	Stroke length (bed length)						
		60 (150)	110 (200)	160 (250)	210 (300)	310 (400)	410 (500)	NEW 600 (700)
TE50B	50							
TE60B	60	50 (150)	100 (200)	200 (300)	300 (400)	400 (500)	500 (600)	600 (700)
TE86B	86	200 (340)	300 (440)	400 (540)	500 (640)	600 (740)	700 (840)	800 (940)

## Features of Precision Positioning Table TE

### 1. Light Weight / Low Profile

Far lighter and with a lower profile than IKO TU series Precision Positioning Tables, the TE series uses a high strength aluminum alloy for its main components with a slide table assembled inside a U-shaped bed. The result: a light weight, compact, precision positioning table.

• Mass unit: kg

Bed width (mm)	TU	TE...B
50	1.8	0.52
60	3.3	1.0
86	10.9	3.7

The value shows the mass of the entire table with 1 standard table.

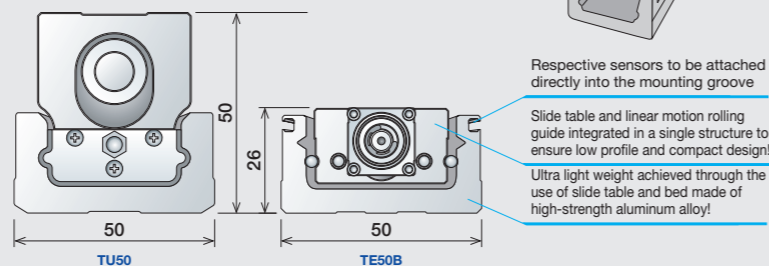

### 2. High Accuracy Positioning

IKO's unique linear motion rolling guide technology utilizes a precision ball screw which enables higher accuracy positioning. For long stroke products, a high lead ball screw is used to achieve high speed and high accuracy positioning in a longer stroke.

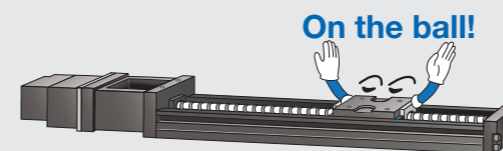

### 3. Long-Term, Maintenance-Free Operation

With built-in **IKO** C-Lube technology, long term maintenance free operation is possible. With C-Lube, lubrication is supplied to the surfaces of the rolling elements, reducing the need for lubrication maintenance and improving machine reliability.

**C-Lube integrated**

Lubrication oil is directly supplied to surfaces of the rolling elements

The surface of C-Lube is always covered with the lubrication oil. Lubrication oil is continuously supplied to the surface of the rolling elements by surface tension in the contact of C-Lube surface and rolling elements.

On the C-Lube surface with which the rolling elements make contact, new lubrication oil is always supplied from the other sections.

# Identification Number and Specification

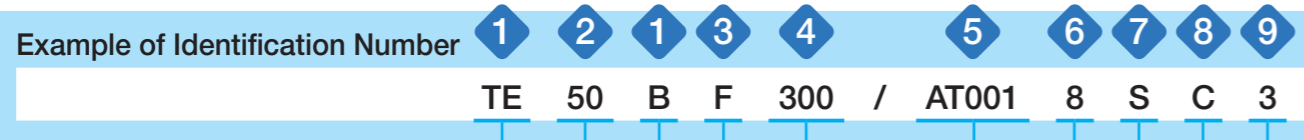

- 1 **Model** TE...B: Precision Positioning Table TE
- 2 **Size** Size indicates bed width. Select a size from the list in Table 1.
- 3 **Shape of slide table** S: Standard table  
F: Flange type standard table
- 4 **Bed length** Select a bed length from the list in Table 1.

Table 1 Sizes and bed lengths unit: mm

Model and size	Bed width	Bed length
TE50B	50	150, 200, 250, 300, 400, 500
TE60B	60	150, 200, 300, 400, 500, 600, 700
TE86B	86	340, 440, 540, 640, 740, 840, 940

Remark: For stroke length, please see the dimension tables shown on page 12 and on.

## 5 Designation of motor folding back specification/motor attachment

- AT000 : Motor inline specification without motor attachment
- AT001~AT011 : Motor inline specification with motor attachment
- AR000 : Motor folding back specification without motor attachment
- AR001~AR008 : Motor folding back specification with motor attachment

To specify the motor attachment, select it from the lists in Table 3.1 and Table 3.2.

- Please specify motor attachment applicable to motor for use.
- If motor inline specification with motor attachment is specified, the main body is shipped with the coupling indicated in Table 4 mounted. However, the final position adjustment should be made by customer since it is only temporarily fixed. For a product without motor attachment (AT000), no coupling is attached.
- If motor folding back specification with motor attachment is specified, housing applicable to the specified motor, pulley (on motor side and ball screw side), cover, motor bracket, belt and bolts necessary for assembly are supplied. Motor mounting bolts should be prepared by customer.

## 6 Ball screw lead Select from among ball screw leads applicable to the sizes and bed lengths shown in Table 2.

Table 2 Application of ball screw lead

Model and size	Bed length mm	Ball screw lead mm				
		4	5	8	10	20
TE50B	300 or less	○	-	○	-	-
	400 or more	-	-	○	-	-
TE60B	600 or less	-	○	-	○	-
	700	-	-	-	-	○
TE86B	All	-	-	-	○	○

- 7 **Number of slide tables** S: One unit  
C: Two units
- 8 **Cover specification** 0: Without cover  
C: With bridge cover (applied to TE...BF)
- 9 **Sensor specification**

- 0: Without sensor
- 2: Two units of sensor mounted (limit)
- 3: Three units of sensor mounted (limit, pre-origin)
- 4: Four units of sensor mounted (limit, pre-origin, origin)
- 5: Two sensors attached (limit)
- 6: Three sensors attached (limit, pre-origin)
- 7: Four sensors attached (limit, pre-origin, origin)

If sensor mounting (symbol 2, 3, or 4) is specified, the sensor is mounted into the mounting groove on the side of the bed, and two detecting plates are mounted on the slide table.

If sensor attachment (symbol 5, 6, or 7) is specified, the specified number of sensors are attached, including mounting screws for sensors, nuts, two detecting plates, and mounting screws for the detecting plates.

# Identification Number and Specification

Table 3.1 Application of motor attachment (motor inline specification)

Type	Motor to be used				Flange size mm	Motor attachment			
	Manufacturer	Series	Model	Rated output W		TE50B	TE60B	TE86B	
AC servo motor	YASKAWA ELECTRIC CORPORATION	Σ-V	SGMJV-A5A	50	□40	AT001	AT002	-	
			SGMAV-A5A			AT001	AT002	-	
			SGMJV-01A	100		-	AT002	-	
			SGMAV-01A			-	AT002	-	
			SGMJV-02A	200		-	-	AT003	
			SGMAV-02A			-	-	AT003	
	Mitsubishi Electric Corporation	J3, J4	HF-MP053, HG-MR053	50	□40	AT001	AT002	-	
			HF-KP053, HG-KR053			AT001	AT002	-	
			HF-MP13, HG-MR13	100		-	AT002	-	
			HF-KP13, HG-KR13			-	AT002	-	
			HF-MP23, HG-MR23	200		-	-	AT003	
			HF-KP23, HG-KR23			-	-	AT003	
	Panasonic Corporation	MINAS A5	MSMD5A	50	□38	AT004	AT005	-	
			MSME5A			AT004	AT005	-	
			MSMD01	100		-	AT005	-	
			MSME01			-	AT005	-	
MSMD02			200	-		-	AT006		
MSME02				-		-	AT006		
Hitachi Industrial Equipment Systems Co., Ltd	AD	ADMA-R5L	50	□40	AT001	AT002	-		
		ADMA-01L	100		-	AT002	-		
		ADMA-02L	200		-	-	AT003		
Stepper motor	ORIENTAL MOTOR Co., Ltd.	α step	AR46	-	□42	AT007	-	-	
			AR66			-	-	AT008	
			AR69			-	-	AT008	
		RK CRK	RK54 · CRK54	-		□42	AT009	-	-
			RK56 · CRK56 (¹)				-	-	-
			-				□60	-	AT010

Note (¹) Applicable to the outer diameter φ8 of motor output shaft.

Remark: For detailed motor specifications, please see respective motor manufacturer's catalog.

Table 3.2 Application of NEMA motor attachment (motor inline specification)

Type	Motor to be used				Flange size inch	Motor attachment		
	Manufacturer	Series	Model	Rated output W		TE50B	TE60B	TE86B
AC servo motor	Allen-Bradley	TLY(metric)	TLY-A110(AA type)	41	□40	AT001	AT002	-
			TLY-A120(AA type)	86	□40	AT001	AT002	-
			TLY-A130(AA type)	140	□40	AT001	AT002	-
			TLY-A220(AA type)	350	□60	-	-	AT003 (²)
			TLY-A230(AA type)	440	□60	-	-	AT003 (²)
		TLY(NEMA)	TLY-A120(AN type)	86	□42	TAE9043-ATE137 (¹)	-	-
			TLY-A130(AN type)	140	□42	TAE9043-ATE137 (¹)	-	-
			TLY-A220(AN type)	350	□56.4	-	-	TAE9017-ATE135 (¹)
			TLY-A230(AN type)	440	□56.4	-	-	TAE9017-ATE135 (¹)
			TLY-A2530(AN type)	690	□86	-	-	TAE9056-ATE134 (¹)
			TLY-A2540(AN type)	860	□86	-	-	TAE9056-ATE134 (¹)
			-	-	-	-	-	-
Servo or Stepper	NEMA17C	-	-	-	TAE9043-ATE110 (¹)(²)	-	-	
	NEMA23D	-	-	-	TAE9017-ATE096 (¹)(²)	TAE9017-ATE096 (¹)(²)	-	
		-	-	-	TAE9017-ATE096 (¹)(²)	TAE9017-ATE097 (¹)(²)	-	
NEMA34D	-	-	-	-	-	TAE9056-ATE095 (¹)(²)		

Note (¹) The TAE part numbers are the part number of motor attachment component sold separately. In the TE part number, please choose motor attachment code AT000. No Coupling is included. It is required to consider customer's operation patterns for these motor attachment.

(²) Please confirm the length and the diameter of the motor shaft etc., and check the usability of the motor attachment with your motor beforehand.

(³) It is required to change the delivered coupling to XGS-30C-8x12 which is for the 12mm motor shaft by customer.

Remark: For detailed motor specifications, please see respective motor manufacturer's catalog.

## Identification Number and Specification

Table 3.3 Application of motor attachment (motor folding back specification)

Type	Motor to be used				Flange size mm	Motor attachment		
	Manufacturer	Series	Model	Rated output W		TE50B	TE60B	TE86B
AC servo motor	YASKAWA ELECTRIC CORPORATION	Σ-V	SGMJV-A5A	50	□40	AR001	AR002	-
			SGMAV-A5A			AR001	AR002	-
			SGMJV-01A			-	AR002	-
			SGMAV-01A	100		-	AR002	-
			SGMJV-02A			-	-	AR003
			SGMAV-02A			-	-	AR003
	Mitsubishi Electric Corporation	J3, J4	HF-MP053, HG-MR053	50	□40	AR001	AR002	-
			HF-KP053, HG-KR053			AR001	AR002	-
			HF-MP13, HG-MR13			-	AR002	-
			HF-KP13, HG-KR13	100		-	AR002	-
			HF-MP23, HG-MR23			-	-	AR003
			HF-KP23, HG-KR23			-	-	AR003
	Panasonic Corporation	MINAS A5	MSMD5A	50	□38	AR004	AR005	-
			MSME5A			AR004	AR005	-
			MSMD01			-	AR005	-
			MSME01	100		-	AR005	-
			MSMD02			-	-	AR006
			MSME02			-	-	AR006
Hitachi Industrial Equipment Systems Co., Ltd	AD	ADMA-R5L	50	□40	AR001	AR002	-	
		ADMA-01L	100		-	AR002	-	
		ADMA-02L	200		-	-	AR003	
Stepper motor	ORIENTAL MOTOR Co., Ltd.	α step	AR46		□42	AR007	-	-
		RK CRK	RK54 · CRK54			AR008	-	-

Remark: For detailed motor specifications, please see respective motor manufacturer's catalog.

Table 4 Coupling models (motor inline specification)

Motor attachment	Coupling models	Manufacturer	Coupling inertia $J_c$ $\times 10^{-6} \text{kg} \cdot \text{m}^2$
AT001	XGS-19C- 5× 8	Nabeya Bi-tech Kaisha	0.062
AT002	XGS-19C- 5× 8	Nabeya Bi-tech Kaisha	0.062
AT003	XGS-30C- 8×14	Nabeya Bi-tech Kaisha	0.55
AT004	XGS-19C- 5× 8	Nabeya Bi-tech Kaisha	0.062
AT005	XGS-19C- 5× 8	Nabeya Bi-tech Kaisha	0.062
AT006	XGS-30C- 8×11	Nabeya Bi-tech Kaisha	0.55
AT007	XGS-19C- 5× 6	Nabeya Bi-tech Kaisha	0.062
AT008	XGS-30C- 8×10	Nabeya Bi-tech Kaisha	0.55
AT009	XGS-19C- 5× 5	Nabeya Bi-tech Kaisha	0.062
AT010	XGS-19C- 5× 8	Nabeya Bi-tech Kaisha	0.062
AT011	XGS-30C- 8× 8	Nabeya Bi-tech Kaisha	0.55
TAE9043-ATE137	XGS-19C- 5× 6.35	Nabeya Bi-tech Kaisha	0.062
TAE9017-ATE135	XGS-30C- 8×12.7	Nabeya Bi-tech Kaisha	0.55
TAE9056-ATE134	XGS-34C- 8×15.875	Nabeya Bi-tech Kaisha	1.0

Remark: For detailed coupling specification, please see the manufacturer's catalog.

## Specifications

Table 5 Accuracy

Model and size	Bed length	Positioning repeatability	Positioning accuracy (°)	Parallelism in table motion B	Backlash (°)
TE50B	150	±0.002 (±0.020)	0.035	0.008	0.005
	200				
	250				
	300				
	400				
TE60B	500	±0.002 (±0.020)	0.045	0.008	0.005
	150				
	200				
	300				
	400				
	500				
TE86B	600	±0.002 (±0.020)	0.050	0.010	0.005
	700				
	340				
	440				
	540				
	640				
	740				
TE86B	840	±0.002 (±0.020)	0.055	0.012	0.005
	940				
	0.065		0.014		

Note (°) This does not apply to tables of motor folding back specification.

Remarks The values in ( ) are reference values provided that the timing belt tension is properly adjusted in motor folding back specification table.

## Specifications

Table 6 Maximum speed

Motor type	Model and size	Bed length mm	Maximum speed mm/s				
			Lead 4mm	Lead 5mm	Lead 8mm	Lead 10mm	Lead 20mm
AC servomotor	TE50B	300 or less	400	-	800	-	-
		400	-	-	800	-	-
		500	-	-	620	-	-
	TE60B	500 or less	-	500	-	1 000	-
		600	-	350	-	710	-
		700	-	-	-	-	960
	TE86B	540 or less	-	-	-	930	1 860
		640	-	-	-	830	1 630
		740	-	-	-	590	1 170
		840	-	-	-	440	880
Stepper motor	TE50B	300 or less	120	-	240	-	-
		400	-	-	240	-	-
		500	-	-	240	-	-
	TE60B	600 or less	-	150	-	300	-
		700	-	-	-	-	600
	TE86B	940 or less	-	-	-	300	600

Remark: To measure the practical maximum speed, it is required to consider operation patterns based on the motor to be used and load conditions.

Table 7 Allowable moment

Model and size	Allowable moment N·m		
	$T_o$	$T_x$	$T_y$
TE50B	9.8		
TE60B	16.7		
TE86B	49.0		

Remark: The value is for one slide table.

Table 8 Maximum carrying mass

Model and size	Ball screw lead mm	Maximum carrying mass kg	
		Horizontal	Vertical
TE50B	4	12	11
	8	12	7
TE60B	5	17	13
	10	17	8
	20	17	7
TE86B	10	36	18
	20	29	10

Remark: The value is for one flange type standard table.

Specifications

Table 9 Table inertia and starting torque

Model and size	Bed length mm	Table inertia $J_T$ (°) $\times 10^{-5} \text{kg}\cdot\text{m}^2$										Starting torque $T_s$ (°) N·m
		Standard table					Flange type standard table					
		Lead					Lead					
4mm	5mm	8mm	10mm	20mm	4mm	5mm	8mm	10mm	20mm			
TE50B	150	0.057	-	0.071	-	-	0.060	-	0.084	-	-	0.03
	200	0.069	-	0.083	-	-	0.072	-	0.096	-	-	
	250	0.085	-	0.099	-	-	0.088	-	0.112	-	-	
	300	0.097	-	0.111	-	-	0.100	-	0.124	-	-	
	400	-	-	0.139	-	-	-	-	0.152	-	-	
500	-	-	0.167	-	-	-	-	0.180	-	-		
TE60B	150	-	0.13	-	0.17	-	-	0.14	-	0.20	-	0.03
	200	-	0.19	-	0.23	-	-	0.20	-	0.26	-	
	300	-	0.26	-	0.30	-	-	0.27	-	0.33	-	
	400	-	0.33	-	0.36	-	-	0.34	-	0.40	-	
	500	-	0.40	-	0.44	-	-	0.41	-	0.47	-	
	600	-	0.47	-	0.51	-	-	0.48	-	0.54	-	
700	-	-	-	-	0.76	-	-	-	-	0.88		
TE86B	340	-	-	-	0.73	1.19	-	-	-	0.81	1.50	0.05
	440	-	-	-	0.88	1.35	-	-	-	0.95	1.64	
	540	-	-	-	1.03	1.50	-	-	-	1.11	1.80	
	640	-	-	-	1.18	1.64	-	-	-	1.25	1.95	
	740	-	-	-	1.33	1.79	-	-	-	1.41	2.10	
	840	-	-	-	1.48	1.94	-	-	-	1.56	2.25	
940	-	-	-	1.63	2.10	-	-	-	1.71	2.40		

Note (°) When two units of slide table are used, it is about 1.5 times as long as that of one unit, and when table of motor folding back specification is used, it is about twice.

(°) For motor folding back specification, please add the following value to the value in the table.

TE50B:  $0.17 \times 10^{-5} \text{kg}\cdot\text{m}^2$ , TE60B:  $0.39 \times 10^{-5} \text{kg}\cdot\text{m}^2$ , TE86B:  $0.86 \times 10^{-5} \text{kg}\cdot\text{m}^2$

Sensor specification

Table 10 Sensor timing chart

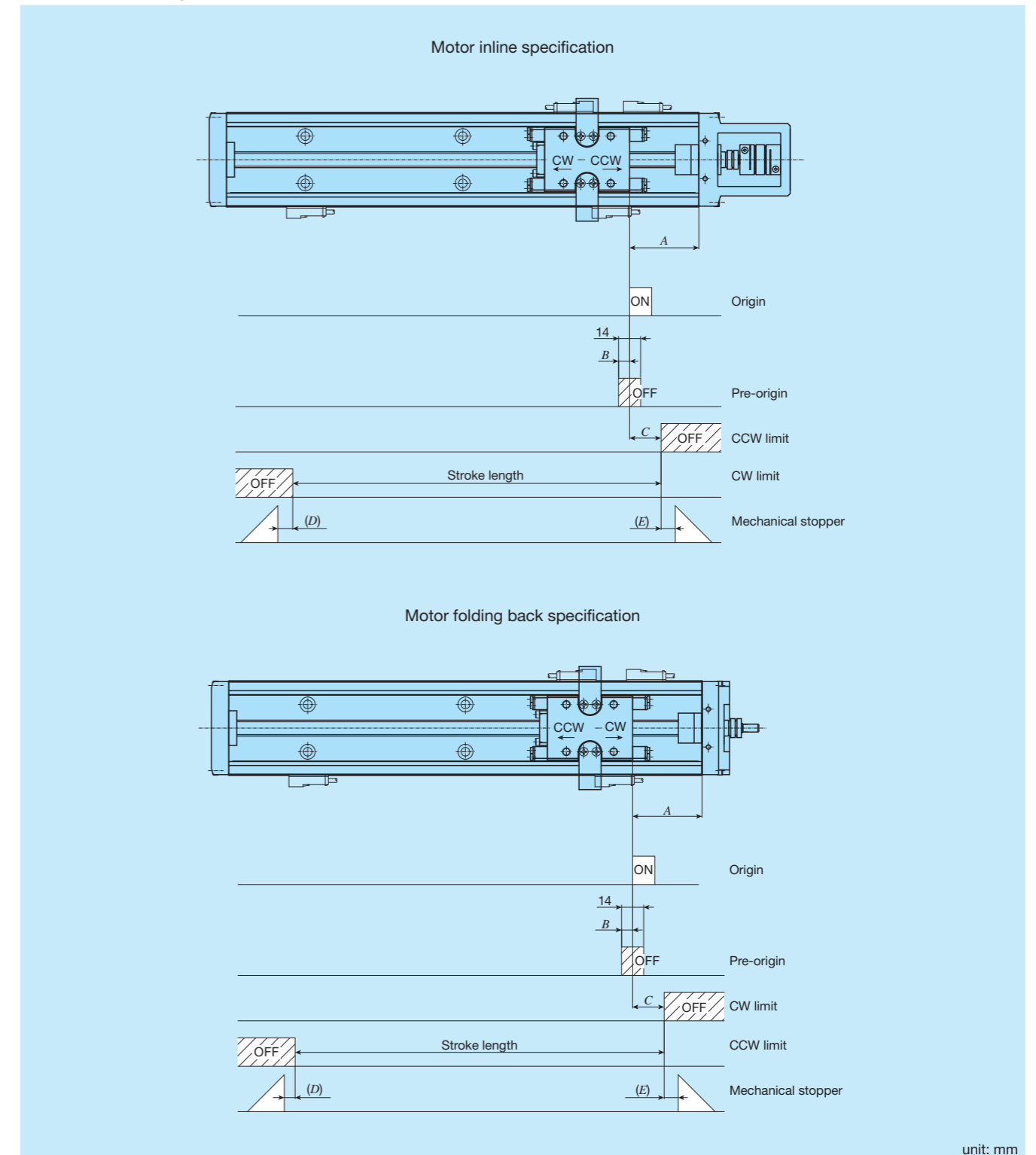

Model and size	Ball screw lead	A	B	C	D(°)	E
TE50B	4	33	2	10	6 ( 9 )	5
	8		6			
TE60B	5	44	3	20	9.5( 8.5)	9
	10		7			
TE86B	10	50	7	20	11 ( 11 )	10
	20		12			

Note (°) The value in ( ) represents dimensions for two slide tables.

Remarks 1. Mounting a sensor is specified using the corresponding identification number.

2. For the specifications of respective sensors, please see the sensor specifications in Table 11.

3. For the motor folding back specification, CW and CCW will invert.

## Sensor specification

Table 11 Sensor specification

Target models		TE...B
Item		
Manufacturer		Azbil Corporation
Model (1)	Pre-origin	APM-D3B1-S APM-D3B1F-S
	CW limit	APM-D3B1-S
	CCW limit	APM-D3B1-S
	Origin	APM-D3A1-S
Shape mm		
Power supply voltage	DC12~24V ±10%	
Current consumption	10mA or less	
Output	NPN open collector · Maximum input current : 30mA or less (resistance load) · Applied voltage : 26.4VDC or less · Residual voltage : 1V or less at input current of 30mA	
Output operation	Pre-origin	OFF in proximity
	Limit	OFF in proximity
	Origin	ON in proximity
Operation indication	Pre-origin	Orange LED (OFF upon detection)
	Limit	Orange LED (OFF upon detection)
	Origin	Orange LED (ON upon detection)
Circuit diagram		

Remarks 1. Wire the sensor cords on your own.

2. Lead runs off by at least 200mm from the table end. Actual length varies depending on stroke length.

Note (1) Model numbers apply to manufacturer standard products. Depending on the total length of the relevant product, the cable length may be different from that of standard products.

## Mounting

### ■ Machining precision of mounting surface

As the accuracy and performance of the table are effective by the precision of the mounting surface of the stand, the parallelism of the stand mounting surface should be 30 μm or less as a guideline for general conditions. However, it must be in accordance with operating conditions such as required motion performance and positioning accuracy. Be sure to remove dirt and harmful protrusions on the mounting surface.

### ■ Tightening torque for fixing screw

Typical tightening torque for fixing the Precision Positioning Table is indicated in the following table. If sudden acceleration / deceleration occurs frequently or moment is applied, it is recommended to tighten them to 1.3 times higher torque than that indicated in the table. In addition, when high accuracy is required with no vibration and shock, it is recommended to tighten the screws to torque smaller than that indicated in the table and use adhesive agent to prevent looseness of screws.

Screw tightening torque

unit: N·m

Bolt size	Female thread component	
	Steel	Aluminum alloy
M4 ×0.7	4.0	About 60% of steel value
M5 ×0.8	7.9	
M6 ×1	13.3	
		Screw insert
		About 80% of steel value

## Dimensions of Motor Attachment

### ■ Motor inline specification

Remark: Motor attachment for NEMA, please see pages III-31 or later of the general catalog.

#### TE50B

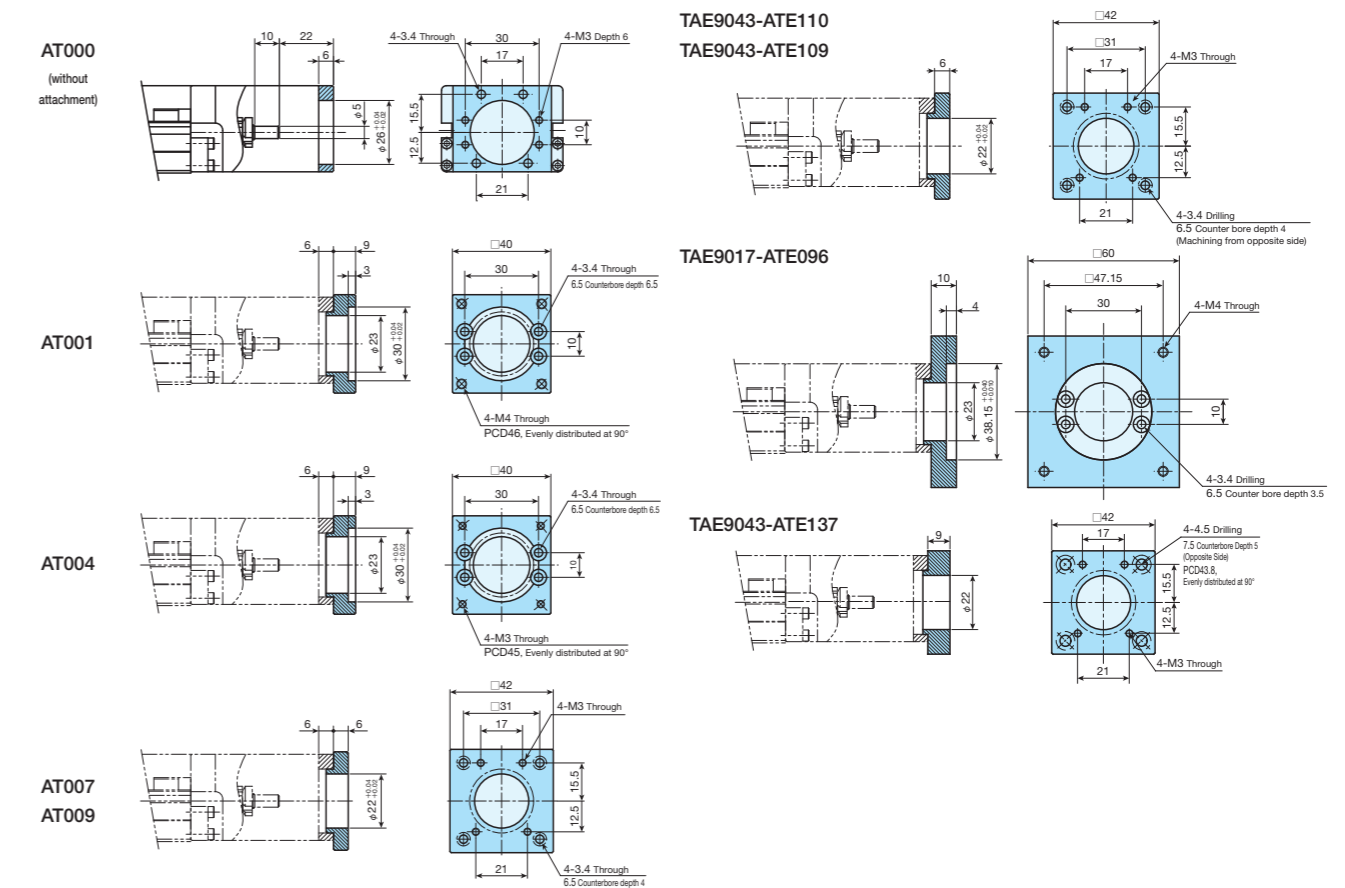

# Dimensions of Motor Attachment

## TE60B

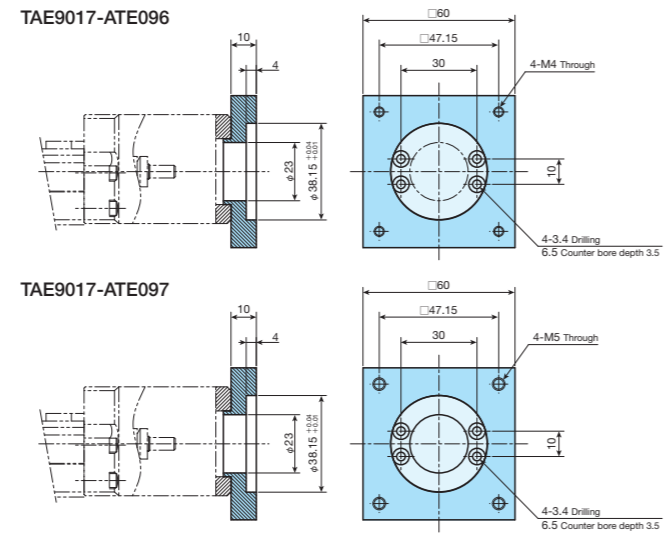
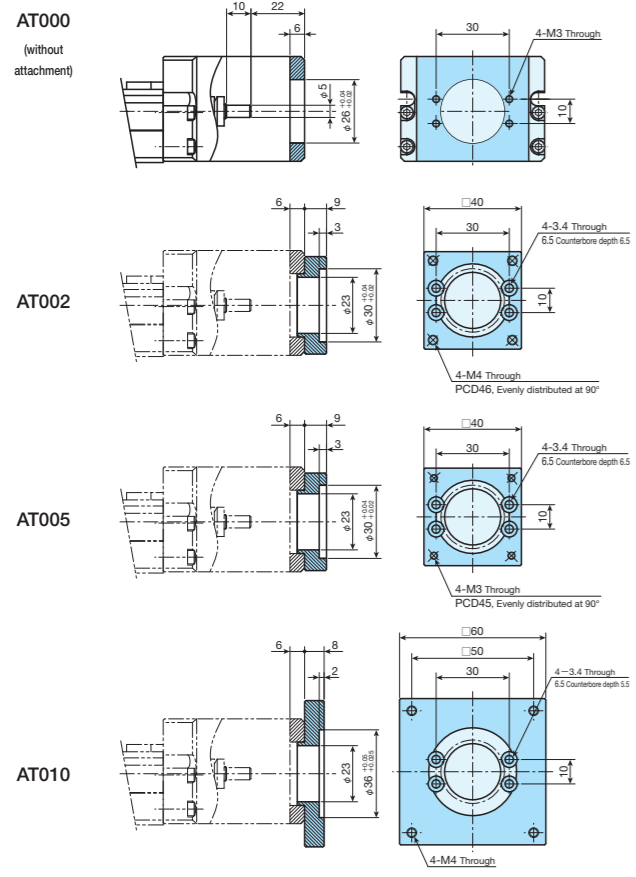

# Dimensions of Motor Attachment

## TE86B

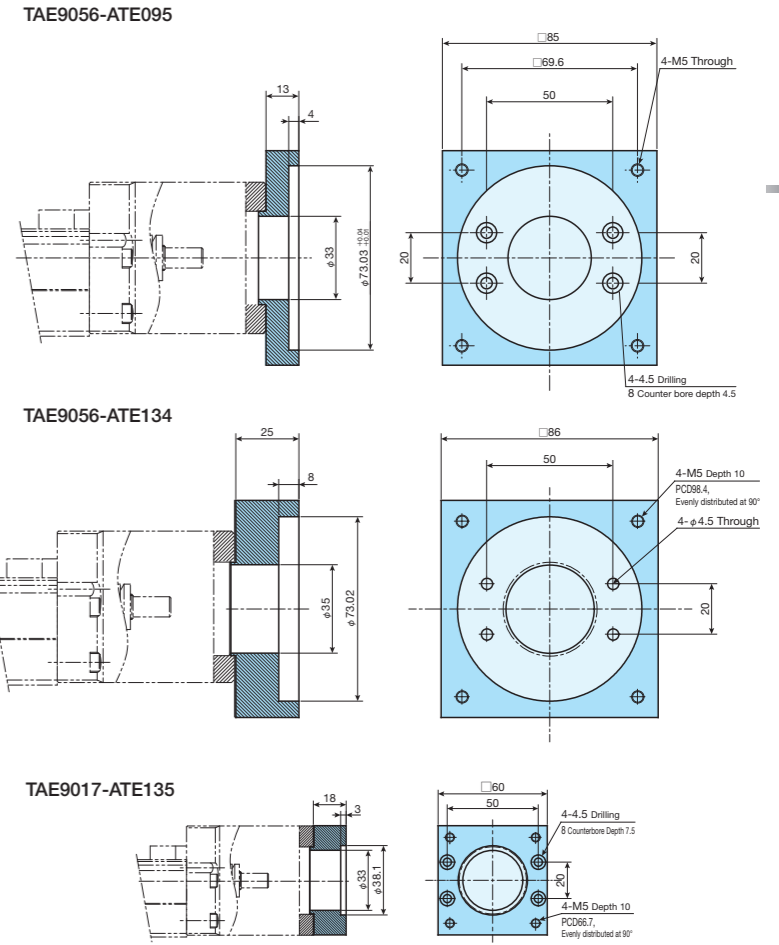
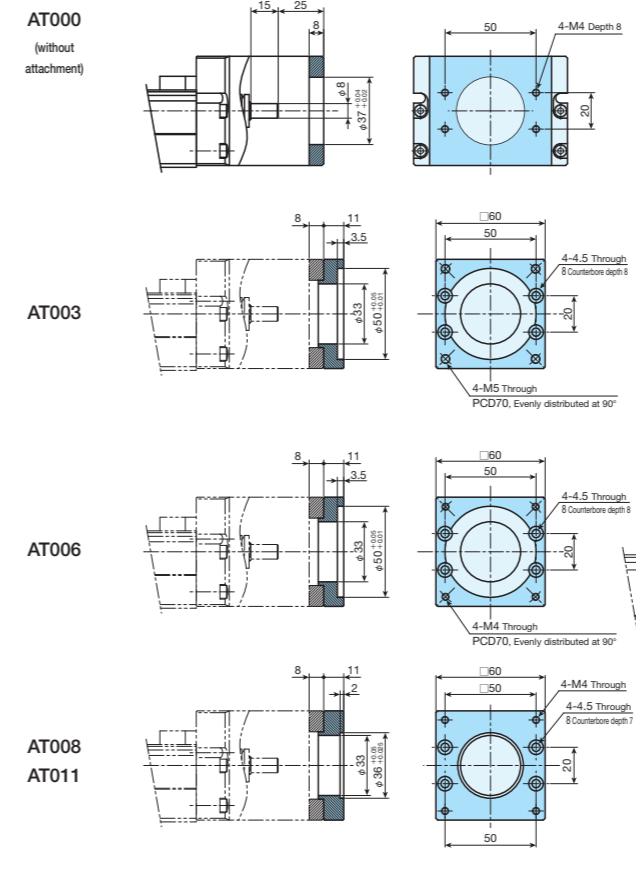

# Dimensions of Motor Attachment

## Motor folding back specification

### TE50B

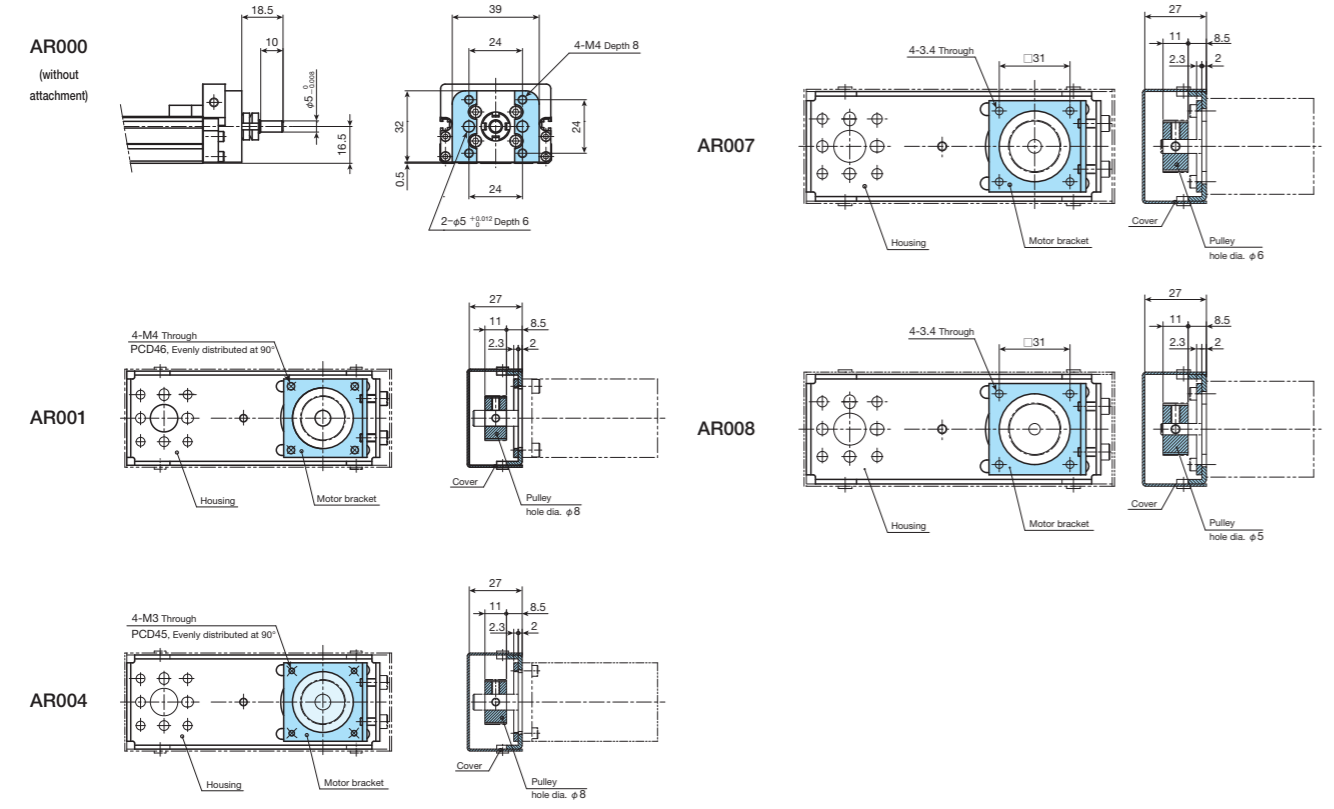

# Dimensions of Motor Attachment

### TE60B

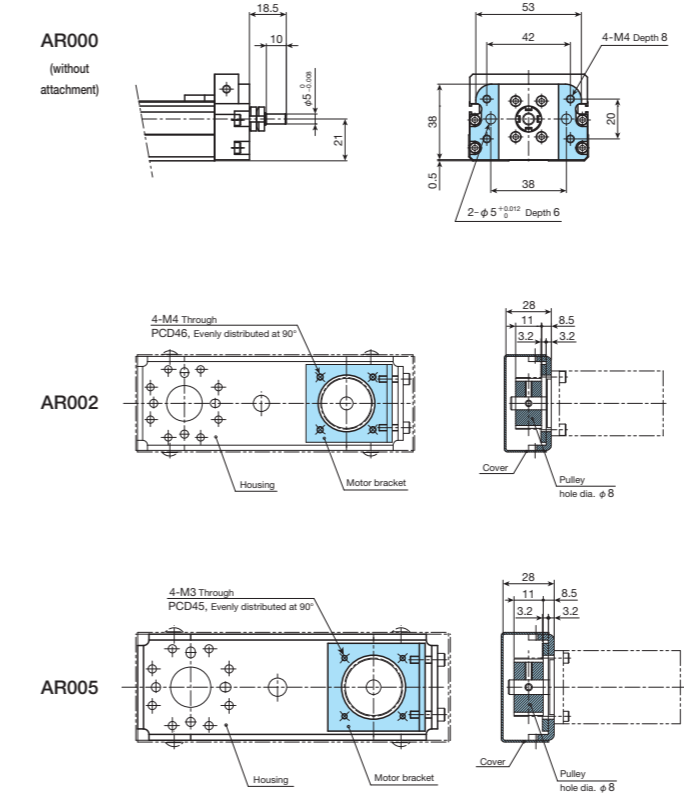

### TE86B

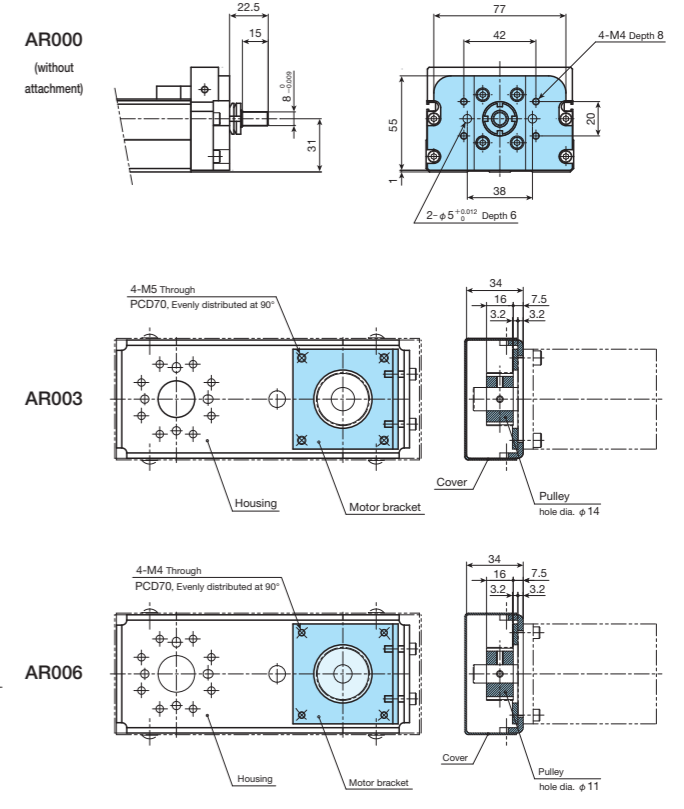



# IKO Precision Positioning Table TE

## TE50BS (Motor inline specification)

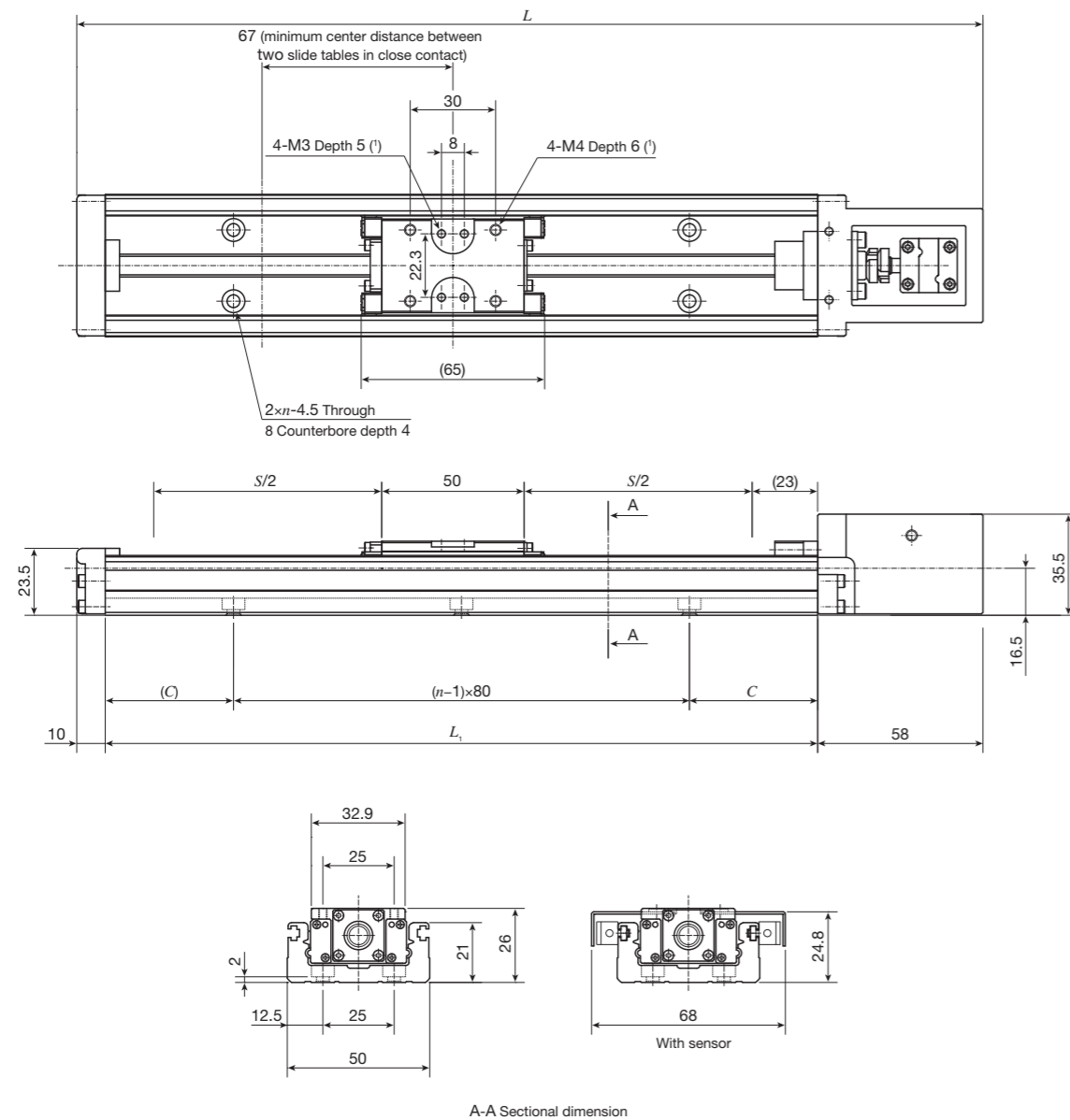

A-A Sectional dimension

unit: mm

Bed length	Overall length	Stroke length	Mounting holes of bed		Mass (Ref.)
$L_1$	$L$	$S^{(1)}$	$C$	$n$	kg <sup>(2)</sup>
150	218	60( - )	35	2	0.52
200	268	110( 40)	20	3	0.62
250	318	160( 90)	45	3	0.72
300	368	210(140)	30	4	0.82
400	468	310(240)	40	5	1.02
500	568	410(340)	10	7	1.22

Note (1) Too deep insertion depth of the mounting bolt may affect the running performance of the slide table, so never insert a bolt longer than the depth of the through hole.

(2) The value indicates the allowable stroke when limit sensors are mounted. The value in ( ) represents dimension for two slide tables in close contact.

(3) The value shows the mass of the entire table with one slide table, and it is 0.07kg heavier with two slide tables.

- Remarks 1. Motor attachment for AC Servomotor is 3.5mm lower than the bottom of the bed.  
2. Motor attachment for stepper motor is 4.5mm lower than the bottom of the bed.

## TE50BF (Motor inline specification)

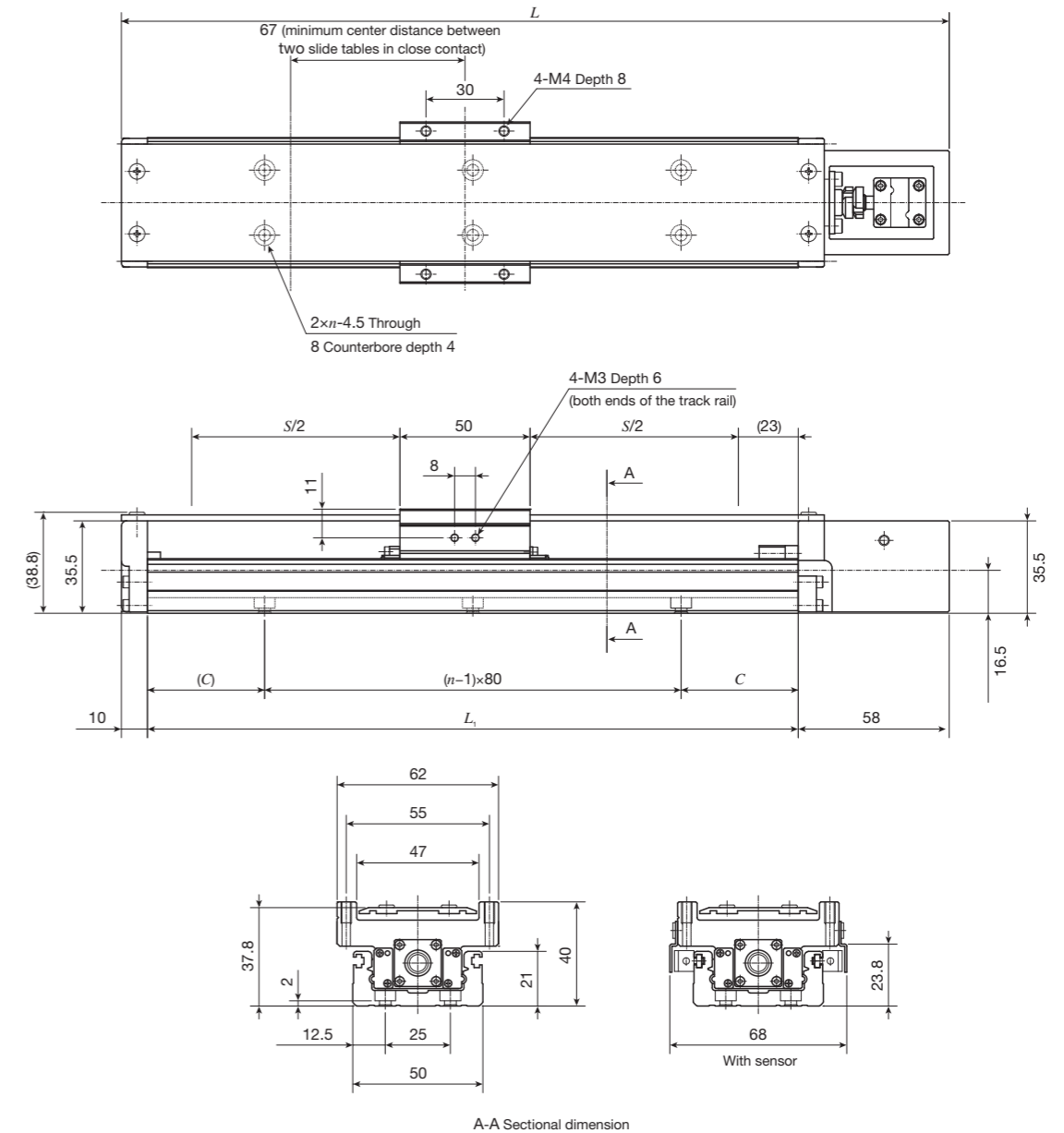

A-A Sectional dimension

unit: mm

Bed length	Overall length	Stroke length	Mounting holes of bed		Mass (Ref.)
$L_1$	$L$	$S^{(1)}$	$C$	$n$	kg <sup>(2)</sup>
150	218	60( - )	35	2	0.65
200	268	110( 40)	20	3	0.75
250	318	160( 90)	45	3	0.85
300	368	210(140)	30	4	0.94
400	468	310(240)	40	5	1.14
500	568	410(340)	10	7	1.33

Note (1) The value indicates the allowable stroke when limit sensors are mounted. The value in ( ) represents dimension for two slide tables in close contact.

(2) The value shows the mass of the entire table with one slide table, and it is 0.16kg heavier with two slide tables.

- Remarks 1. Motor attachment for AC Servomotor is 3.5mm lower than the bottom of the bed.  
2. Motor attachment for stepper motor is 4.5mm lower than the bottom of the bed.

# IKO Precision Positioning Table TE

## TE60BS (Motor inline specification)

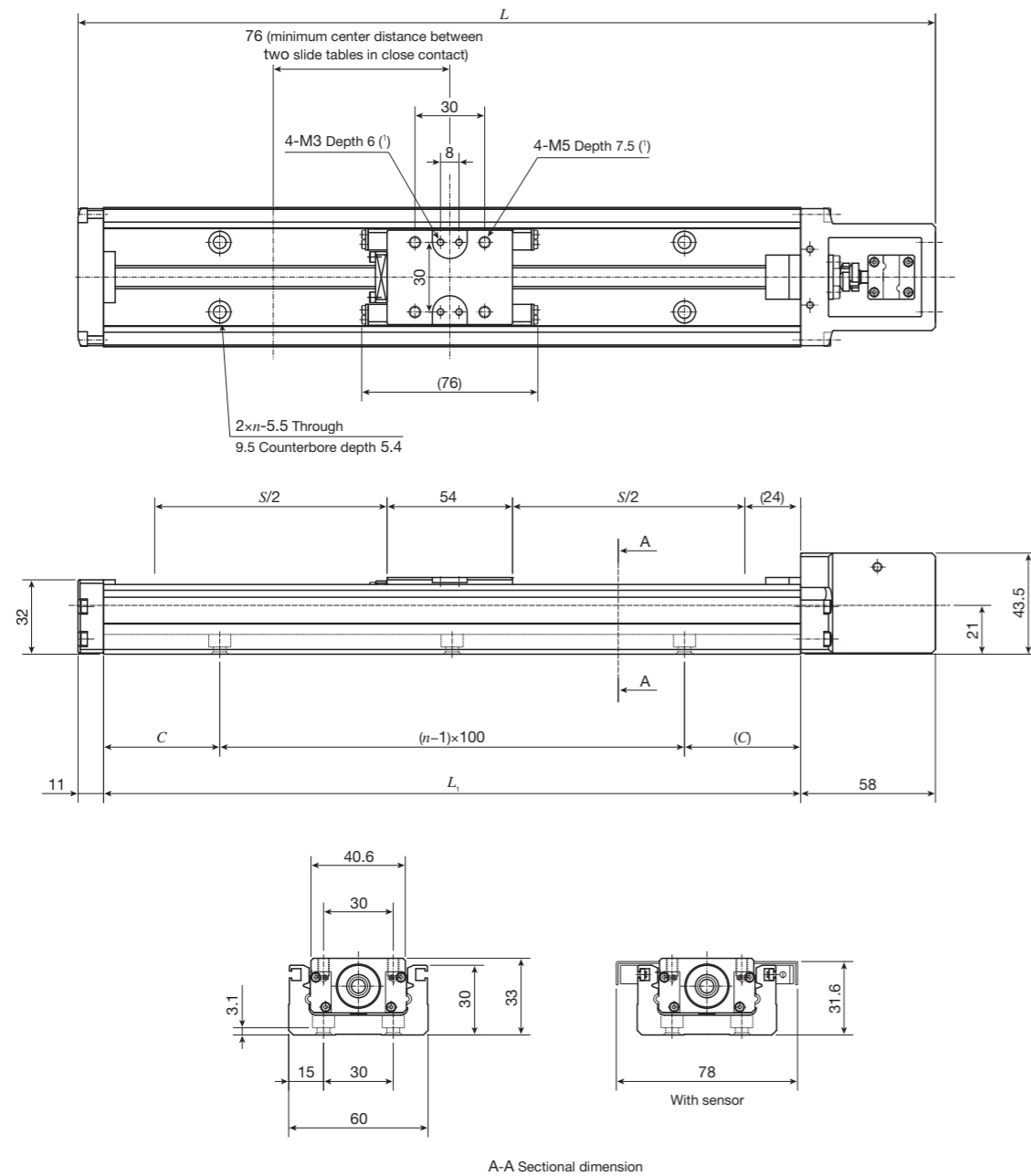

unit: mm

Bed length	Overall length	Stroke length	Mounting holes of bed		Mass (Ref.)
$L_1$	$L$	$S^{(1)}$	$C$	$n$	kg <sup>(2)</sup>
150	219	50( - )	25	2	0.9
200	269	100( - )	50	2	1.0
300	369	200(125)	50	3	1.3
400	469	300(225)	50	4	1.6
500	569	400(325)	50	5	1.9
600	669	500(425)	50	6	2.2
700	769	600(525)	50	7	2.5

Note (1) Too deep insertion depth of the mounting bolt may affect the running performance of the slide table, so never insert a bolt longer than the depth of the through hole.

(2) The value indicates the allowable stroke when limit sensors are mounted. The value in ( ) represents dimension for two slide tables in close contact.

(3) The value shows the mass of the entire table with one slide table, and it is 0.1kg heavier with two slide tables.

Remarks Motor attachment for stepper motor is 9mm lower than the bottom of the bed.

## TE60BF (Motor inline specification)

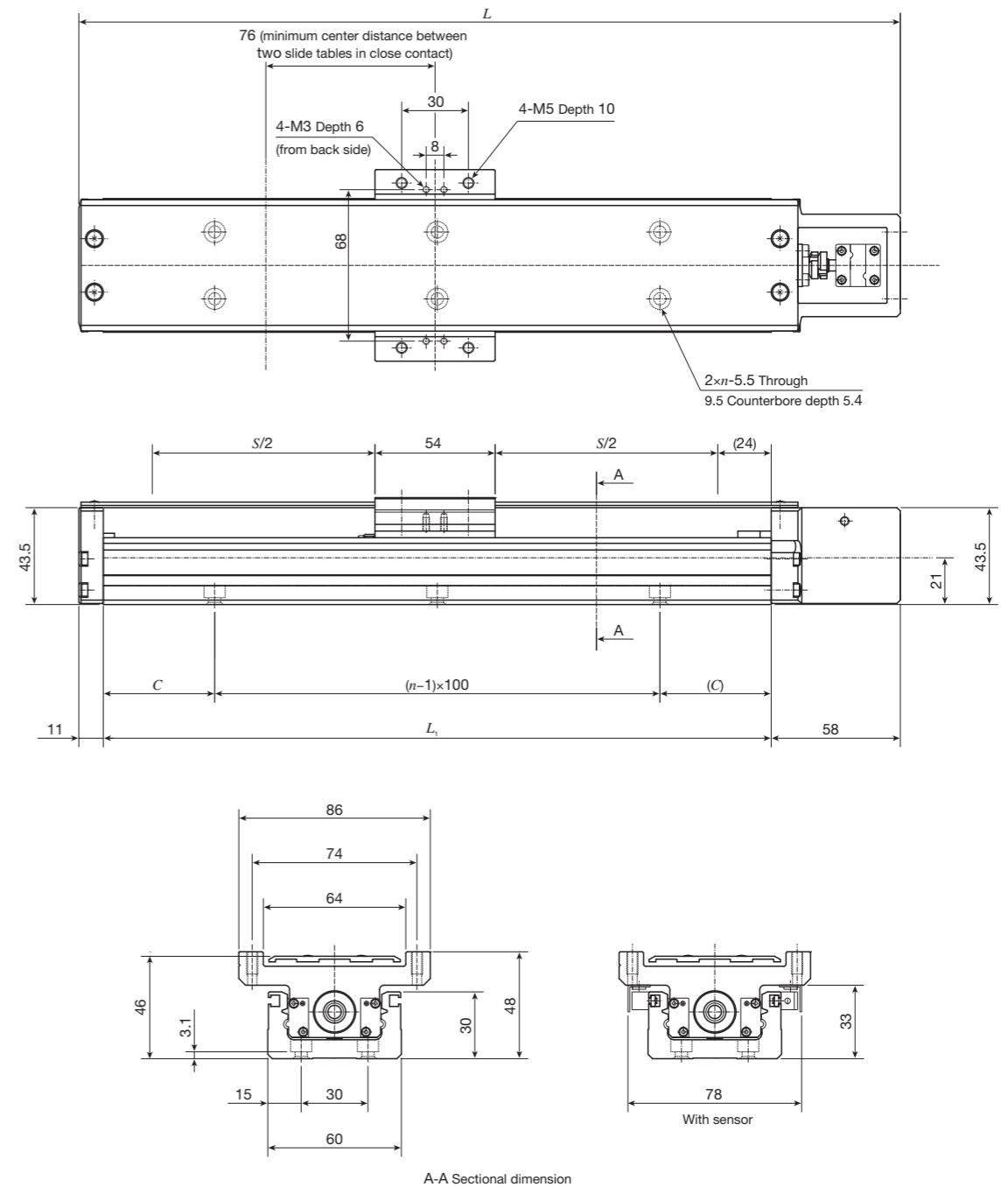

unit: mm

Bed length	Overall length	Stroke length	Mounting holes of bed		Mass (Ref.)
$L_1$	$L$	$S^{(1)}$	$C$	$n$	kg <sup>(2)</sup>
150	219	50( - )	25	2	1.1
200	269	100( - )	50	2	1.2
300	369	200(125)	50	3	1.5
400	469	300(225)	50	4	1.9
500	569	400(325)	50	5	2.2
600	669	500(425)	50	6	2.5
700	769	600(525)	50	7	2.8

Note (1) The value indicates the allowable stroke when limit sensors are mounted. The value in ( ) represents dimension for two slide tables in close contact.

(2) The value shows the mass of the entire table with one slide table, and it is 0.2kg heavier with two slide tables.

Remarks Motor attachment for stepper motor is 9mm lower than the bottom of the bed.

1N=0.102kgf=0.2248lbs.  
1mm=0.03937inch

# IKO Precision Positioning Table TE

## TE86BS (Motor inline specification)

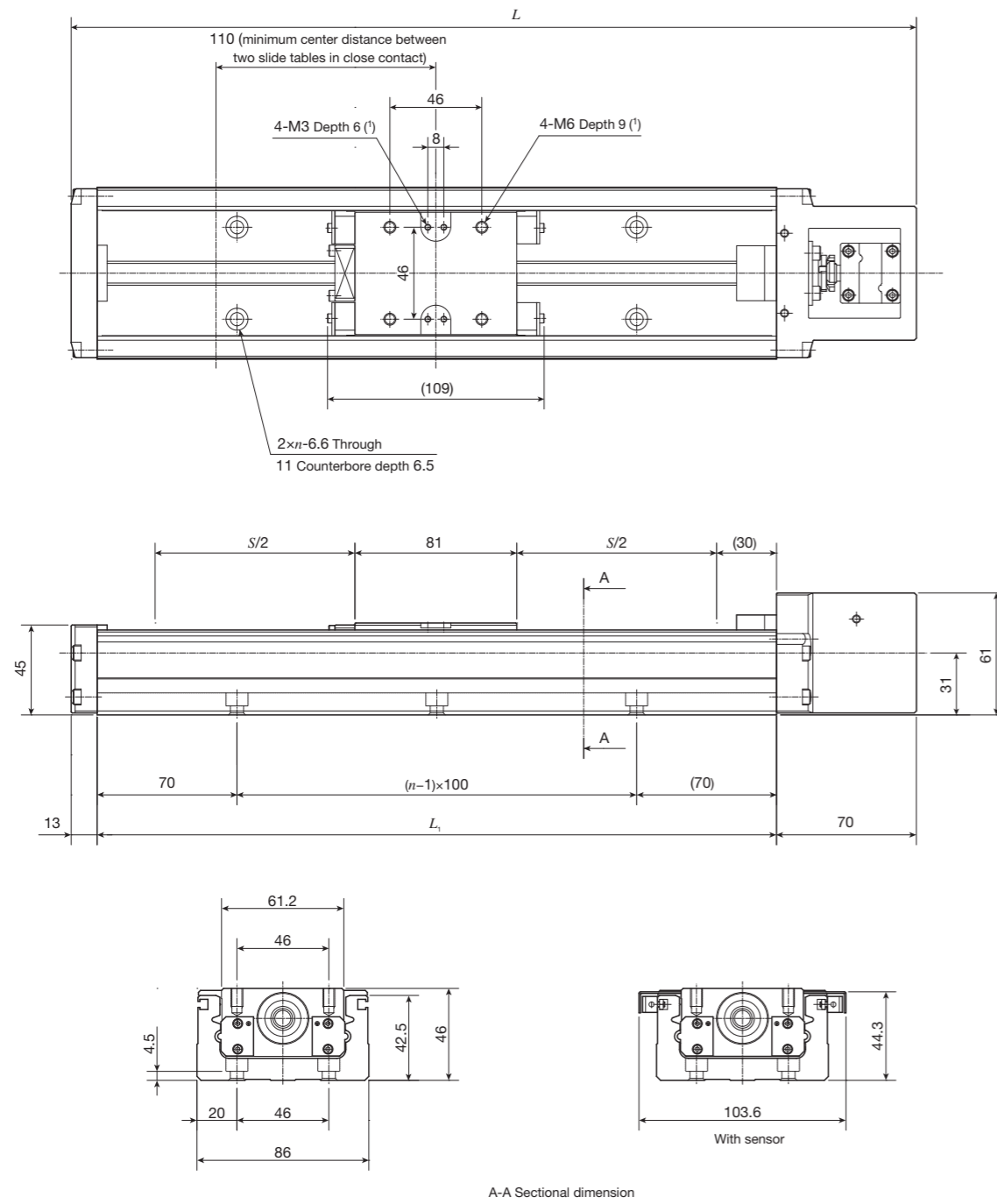

unit: mm

Bed length	Overall length	Stroke length	Mounting holes of bed	Mass(Ref.)
$L_1$	$L$	$S^{(2)}$	$n$	kg <sup>(3)</sup>
340	423	200( 90)	3	3.1
440	523	300(190)	4	3.7
540	623	400(290)	5	4.2
640	723	500(390)	6	4.7
740	823	600(490)	7	5.2
840	923	700(590)	8	5.7
940	1 023	800(690)	9	6.3

Notes (1) Too deep a fixing thread depth of the mounting bolt may affect the running performance of the slide table, so never insert a bolt longer than the depth of the tapped hole.

(2) The value indicates the allowable stroke when limit sensors are mounted. The value in ( ) represents dimension for two slide tables in close contact.

(3) The value shows the mass of the entire table with one slide table, and it is 0.3kg heavier with two slide tables.

## TE86BF (Motor inline specification)

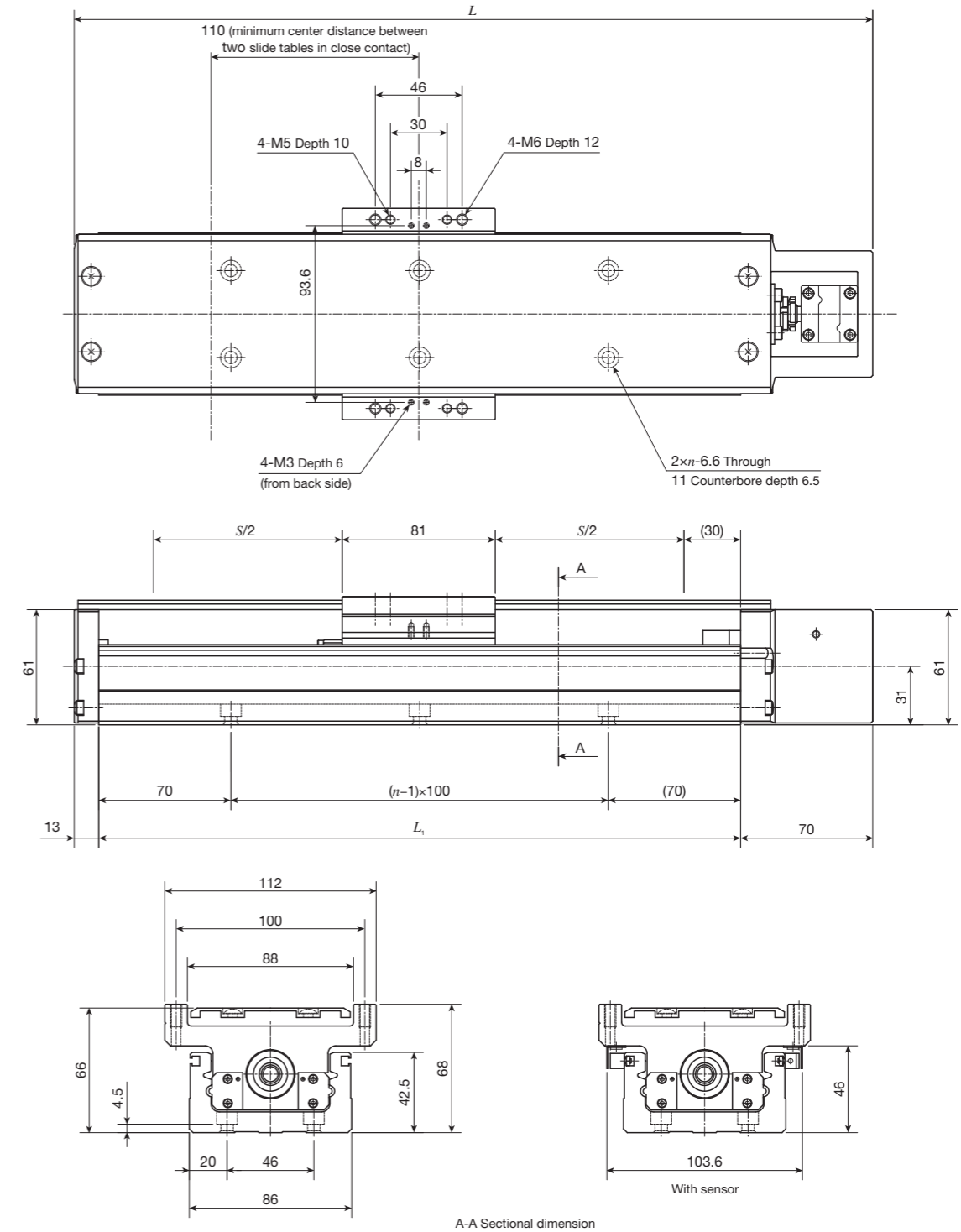

A-A Sectional dimension

unit: mm

Bed length	Overall length	Stroke length	Mounting holes of bed	Mass(Ref.)
$L_1$	$L$	$S^{(1)}$	$n$	kg <sup>(2)</sup>
340	423	200( 90)	3	3.7
440	523	300(190)	4	4.3
540	623	400(290)	5	4.9
640	723	500(390)	6	5.5
740	823	600(490)	7	6.1
840	923	700(590)	8	6.7
940	1 023	800(690)	9	7.2

Notes (1) The value indicates the allowable stroke when limit sensors are mounted. The value in ( ) represents dimension for two slide tables in close contact.

(2) The value shows the mass of the entire table with one slide table, and it is 0.6kg heavier with two slide tables.

# IKO Precision Positioning Table TE

## TE50BS (Motor folding back specification)

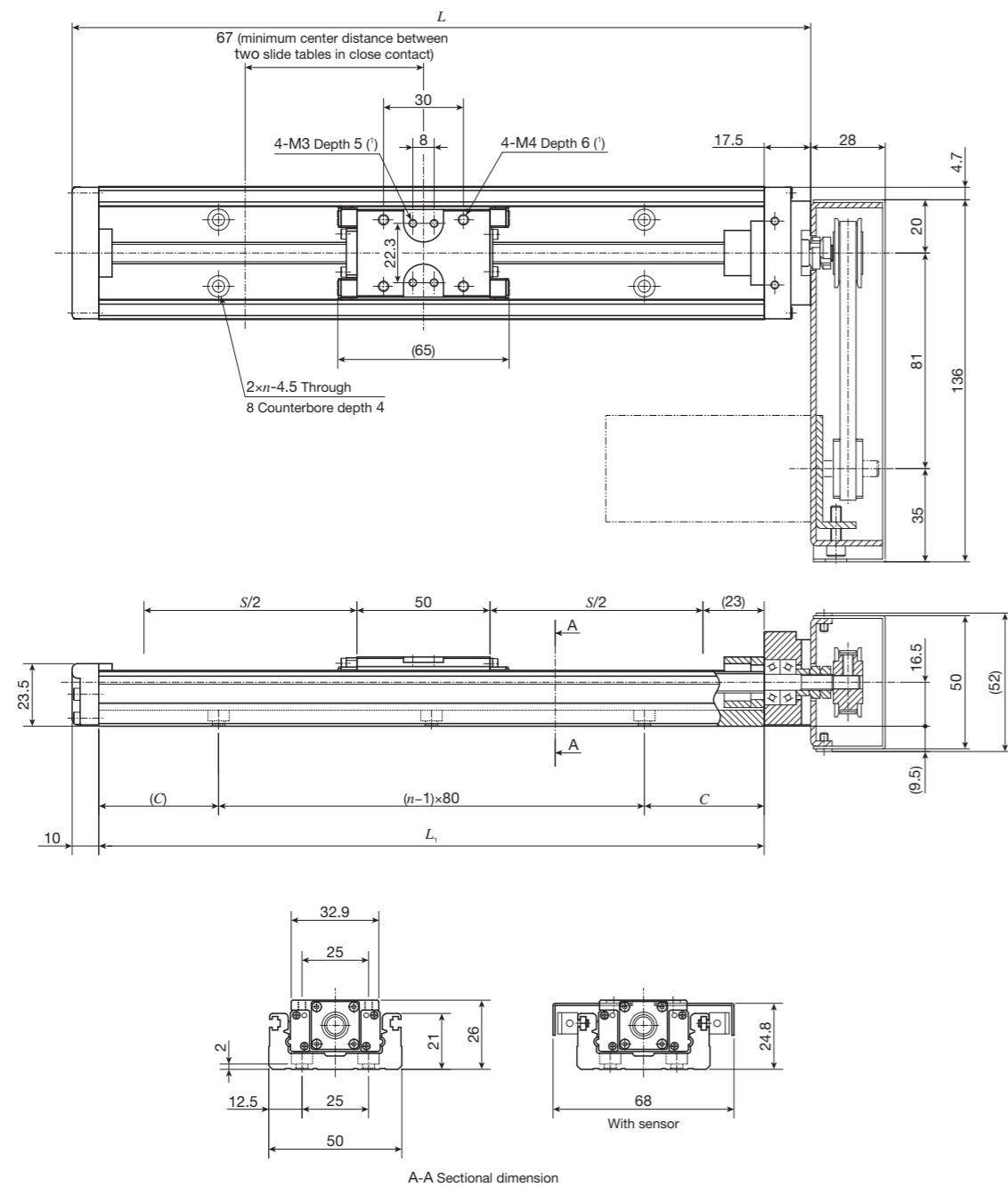

unit: mm

Bed length	Overall length	Stroke length	Mounting holes of bed		Mass (Ref.)
$L_1$	$L$	$S^{(1)}$	$C$	$n$	kg <sup>(2)</sup>
150	177.5	60( - )	35	2	0.72
200	227.5	110( 40)	20	3	0.82
250	277.5	160( 90)	45	3	0.92
300	327.5	210(140)	30	4	1.02
400	427.5	310(240)	40	5	1.22
500	527.5	410(340)	10	7	1.42

Note (1) Too deep insertion depth of the mounting bolt may affect the running performance of the slide table, so never insert a bolt longer than the depth of the through hole.

(2) The value indicates the allowable stroke when limit sensors are mounted. The value in ( ) represents dimension for two slide tables in close contact.

(3) The value shows the mass of the entire table with one slide table, and it is 0.07kg heavier with two slide tables.

Remarks 1. Parts for motor attachment are appended, and this figure indicates a finished state after assembled by the customer.

2. If folded back to right and left, motor attachment is about 9.5mm lower than the bottom of the bed. In addition, it is about 2.5 to 3.5mm lower than the bottom of the bed if AC Servomotor is mounted by customers, and about 4.5mm lower if stepper motor is mounted.

3. If folded back upward, motor attachment is about 3.5mm lower than the bottom of the bed.

## TE50BF (Motor folding back specification)

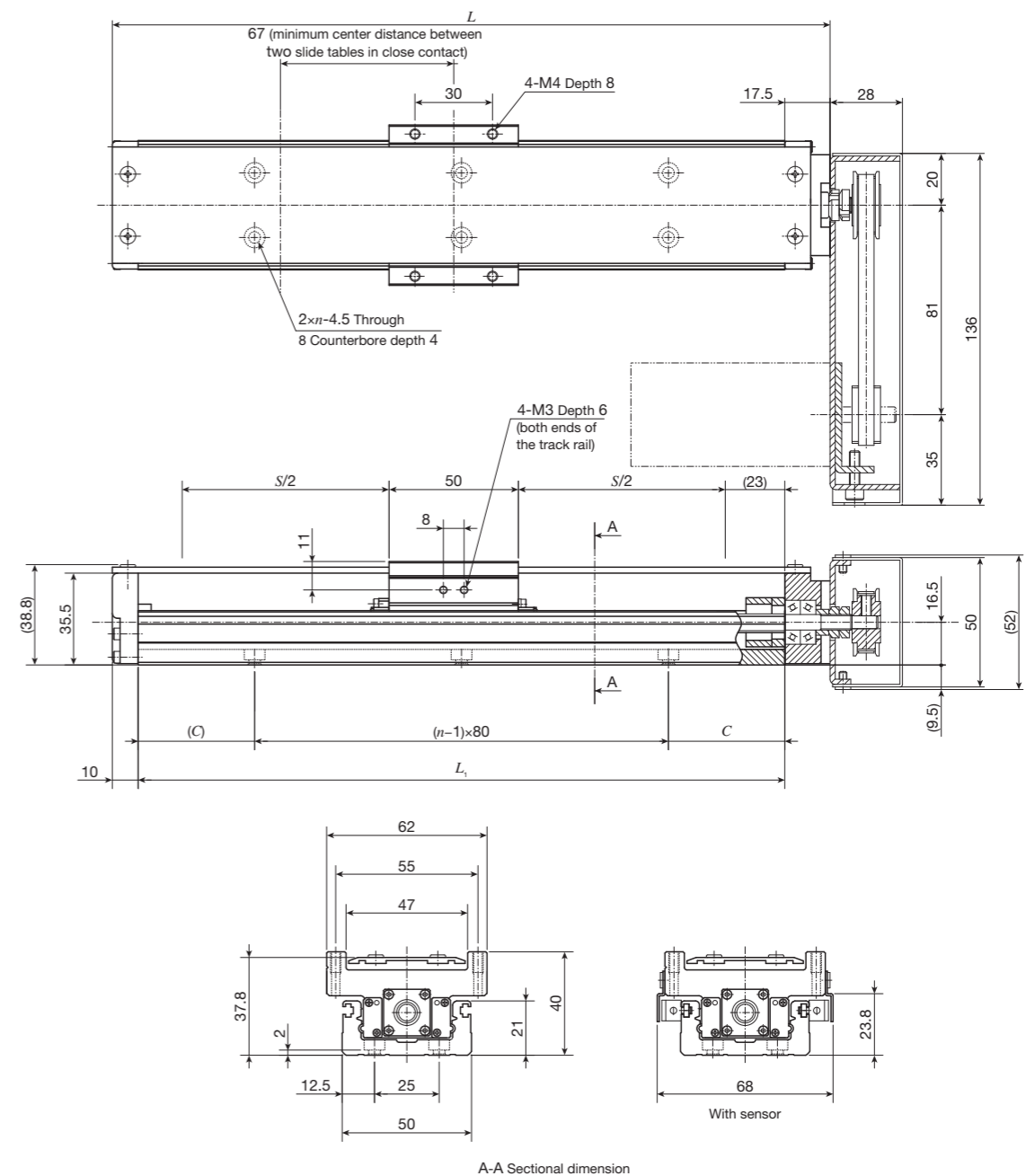

unit: mm

Bed length	Overall length	Stroke length	Mounting holes of bed		Mass (Ref.)
$L_1$	$L$	$S^{(1)}$	$C$	$n$	kg <sup>(2)</sup>
150	177.5	60( - )	35	2	0.85
200	227.5	110( 40)	20	3	0.95
250	277.5	160( 90)	45	3	1.05
300	327.5	210(140)	30	4	1.15
400	427.5	310(240)	40	5	1.35
500	527.5	410(340)	10	7	1.55

Note (1) The value indicates the allowable stroke when limit sensors are mounted. The value in ( ) represents dimension for two slide tables in close contact.

(2) The value shows the mass of the entire table with one slide table, and it is 0.16kg heavier with two slide tables.

Remarks 1. Parts for motor attachment are appended, and this figure indicates a finished state after assembled by the customer.

2. If folded back to right and left, motor attachment is about 9.5mm lower than the bottom of the bed. In addition, it is about 2.5 to 3.5mm lower than the bottom of the bed if AC Servomotor is mounted by customers, and about 4.5mm lower if stepper motor is mounted.

3. If folded back upward, motor attachment is about 3.5mm lower than the bottom of the bed.

# IKO Precision Positioning Table TE

## TE60BS (Motor folding back specification)

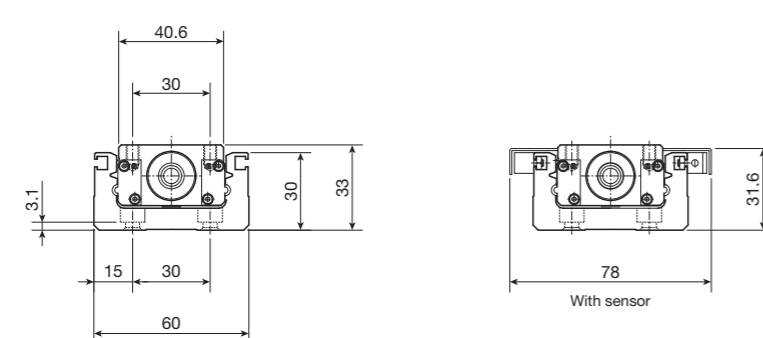
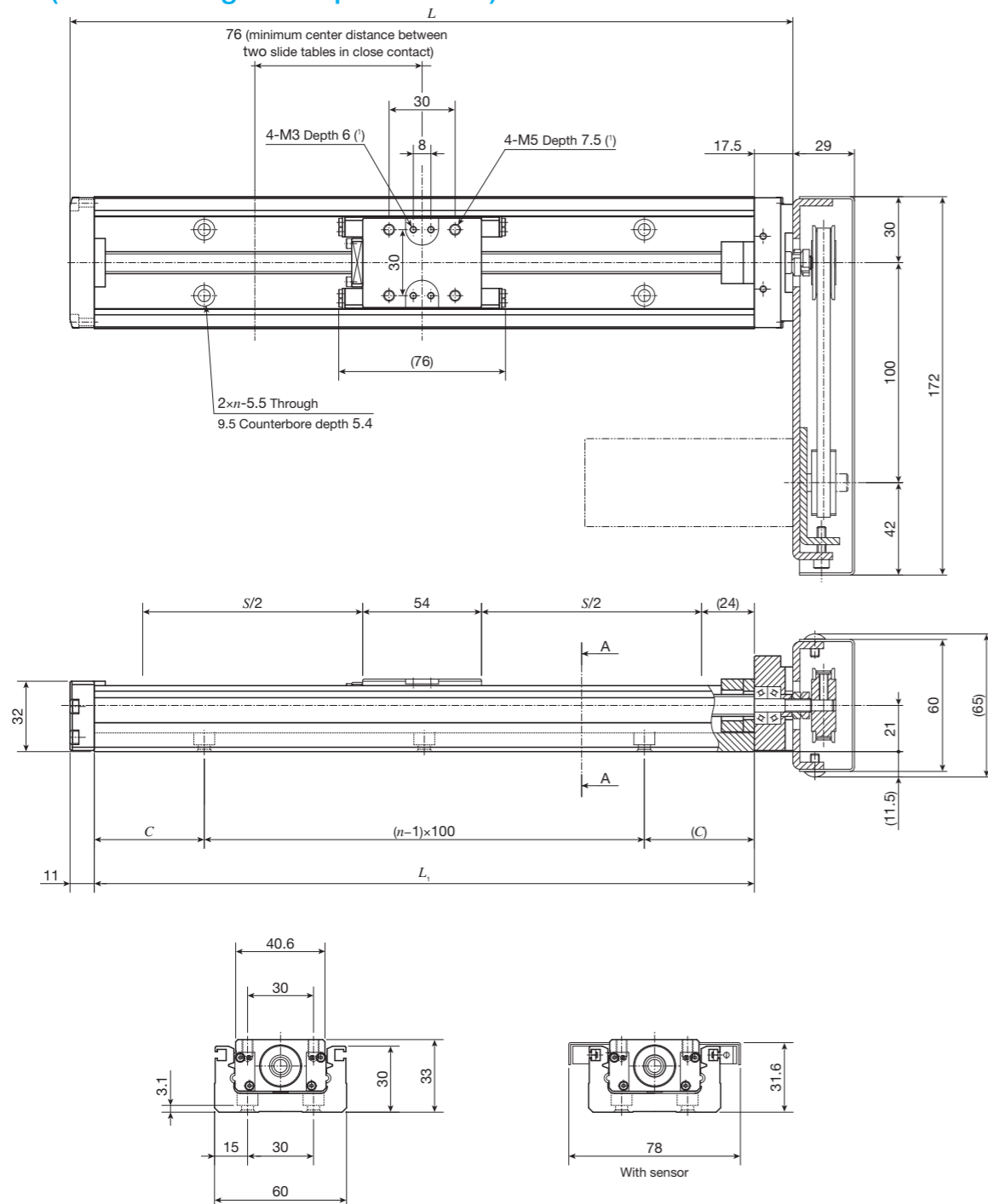

A-A Sectional dimension unit: mm

Bed length	Overall length	Stroke length	Mounting holes of bed		Mass (Ref.)
$L_1$	$L$	$S^{(2)}$	$C$	$n$	kg <sup>(3)</sup>
150	178.5	50( - )	25	2	1.2
200	228.5	100( - )	50	2	1.3
300	328.5	200(125)	50	3	1.6
400	428.5	300(225)	50	4	1.9
500	528.5	400(325)	50	5	2.2
600	628.5	500(425)	50	6	2.5
700	728.5	600(525)	50	7	2.8

Note (1) Too deep insertion depth of the mounting bolt may affect the running performance of the slide table, so never insert a bolt longer than the depth of the through hole.  
 (2) The value indicates the allowable stroke when limit sensors are mounted. The value in ( ) represents dimension for two slide tables in close contact.  
 (3) The value shows the mass of the entire table with one slide table, and it is 0.1kg heavier with two slide tables.

Remarks 1. Parts for motor attachment are appended, and this figure indicates a finished state after assembled by the customer.  
 2. If folded back to right and left, motor attachment is about 11.5mm lower than the bottom of the bed.  
 3. If folded back upward, motor attachment is about 9mm lower than the bottom of the bed.

## TE60BF (Motor folding back specification)

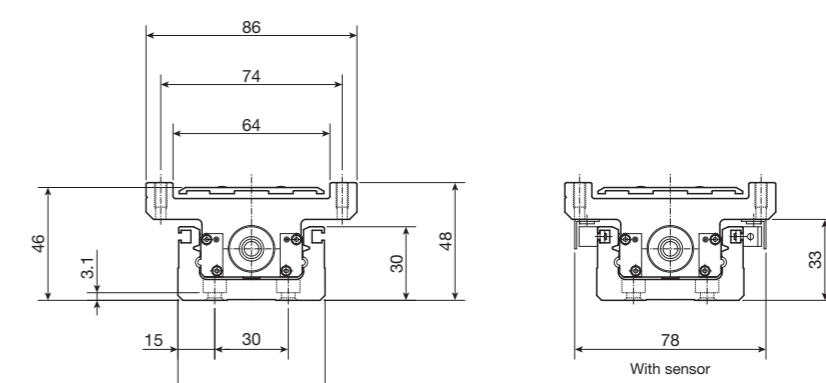
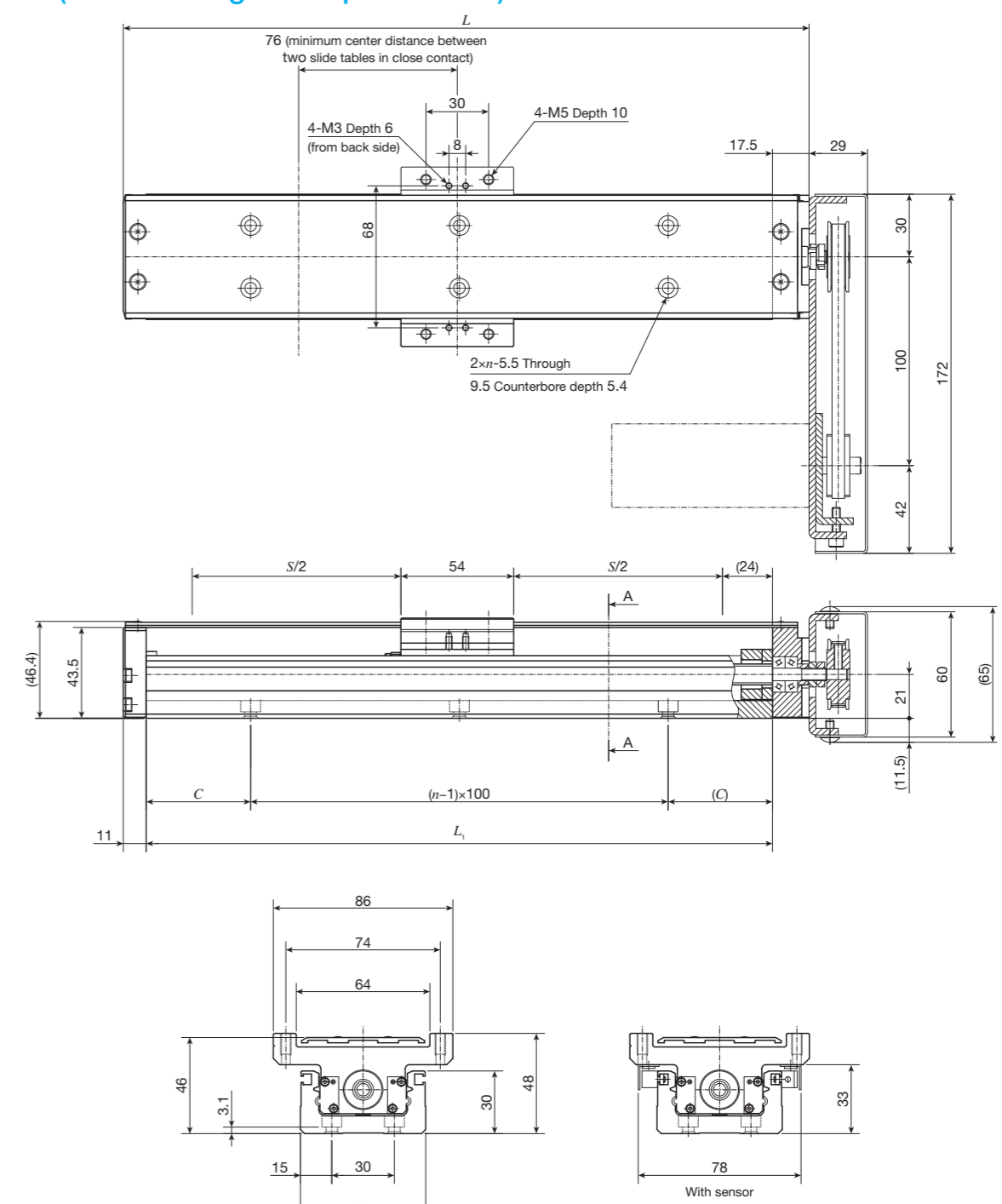

A-A Sectional dimension unit: mm

Bed length	Overall length	Stroke length	Mounting holes of bed		Mass (Ref.)
$L_1$	$L$	$S^{(1)}$	$C$	$n$	kg <sup>(2)</sup>
150	178.5	50( - )	25	2	1.4
200	228.5	100( - )	50	2	1.5
300	328.5	200(125)	50	3	1.8
400	428.5	300(225)	50	4	2.2
500	528.5	400(325)	50	5	2.5
600	628.5	500(425)	50	6	2.8
700	728.5	600(525)	50	7	3.1

Note (1) The value indicates the allowable stroke when limit sensors are mounted. The value in ( ) represents dimension for two slide tables in close contact.  
 (2) The value shows the mass of the entire table with one slide table, and it is 0.2kg heavier with two slide tables.

Remarks 1. Parts for motor attachment are appended, and this figure indicates a finished state after assembled by the customer.  
 2. If folded back to right and left, motor attachment is about 11.5mm lower than the bottom of the bed.  
 3. If folded back upward, motor attachment is about 9mm lower than the bottom of the bed.

# IKO Precision Positioning Table TE

## TE86BS (Motor folding back specification)

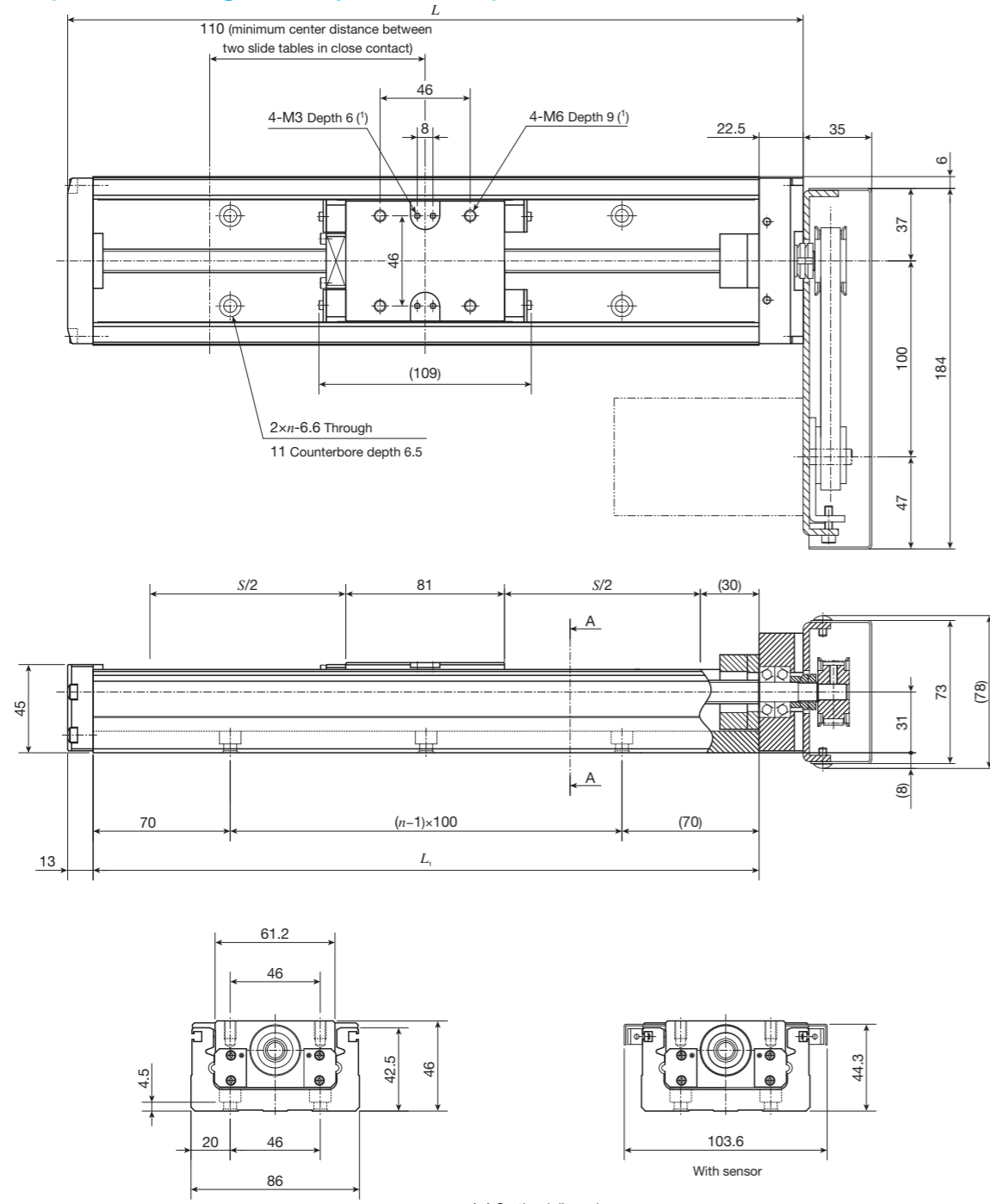

A-A Sectional dimension

unit: mm

Bed length	Overall length	Stroke length	Mounting holes of bed	Mass(Ref.)
$L_1$	$L$	$S^{(2)}$	$n$	kg <sup>(3)</sup>
340	375.5	200( 90)	3	4.0
440	475.5	300(190)	4	4.6
540	575.5	400(290)	5	5.1
640	675.5	500(390)	6	5.6
740	775.5	600(490)	7	6.1
840	875.5	700(590)	8	6.6
940	975.5	800(690)	9	7.2

Notes (1) Too deep a fixing thread depth of the mounting bolt may affect the running performance of the slide table, so never insert a bolt longer than the depth of the tapped hole.

(2) The value indicates the allowable stroke when limit sensors are mounted. The value in ( ) represents dimension for two slide tables in close contact.

(3) The value shows the mass of the entire table with one slide table, and it is 0.3kg heavier with two slide tables.

Remarks 1. Parts for motor attachment are appended, and this figure indicates a finished state after assembled by the customer.

2. If folded back to right and left, motor attachment is about 8mm lower than the bottom of the bed.

3. If folded back upward, motor attachment is about 6mm lower than the bottom of the bed.

## TE86BF (Motor folding back specification)

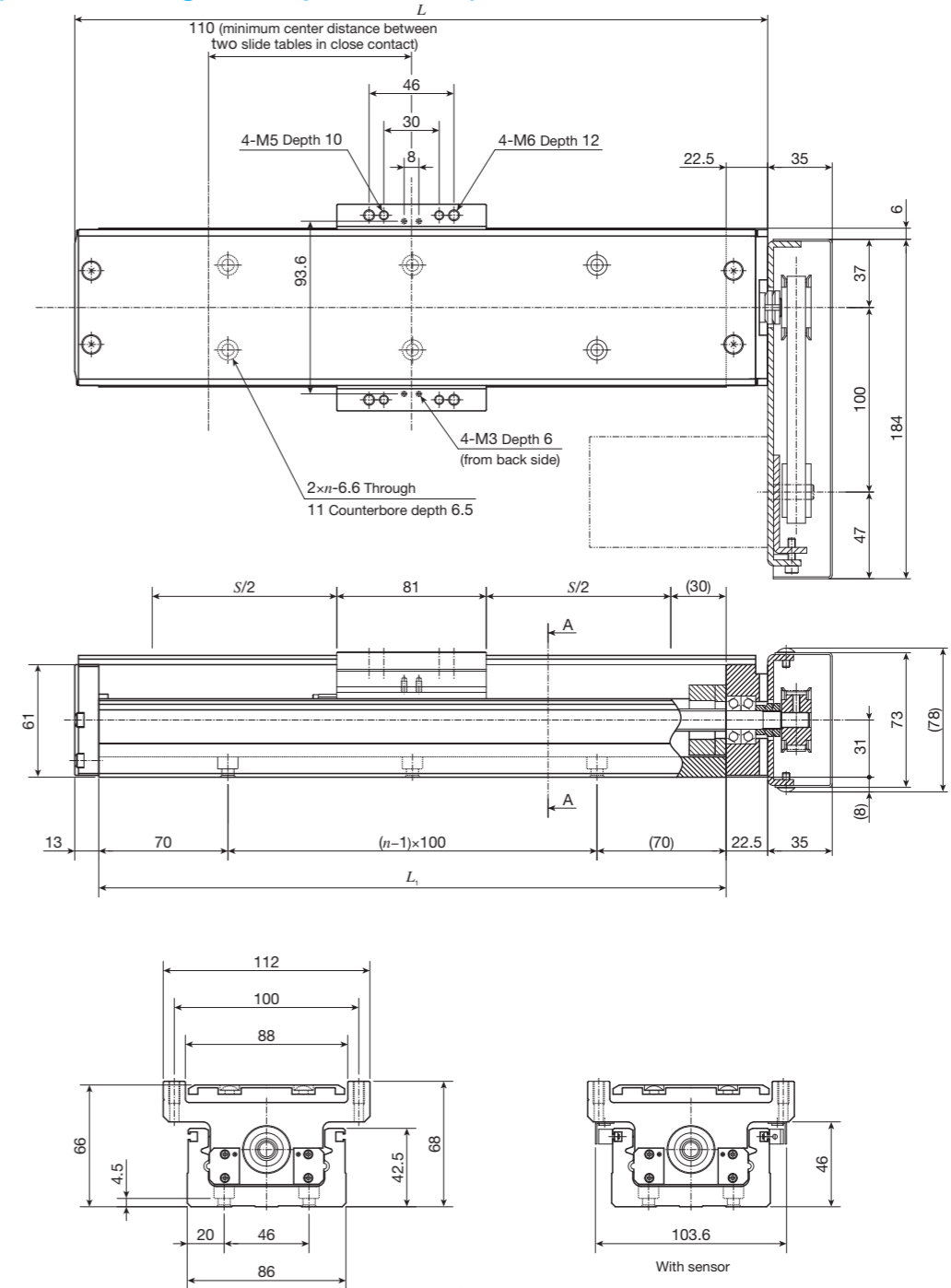

A-A Sectional dimension

unit: mm

Bed length	Overall length	Stroke length	Mounting holes of bed	Mass(Ref.)
$L_1$	$L$	$S^{(1)}$	$n$	kg <sup>(2)</sup>
340	375.5	200( 90)	3	4.6
440	475.5	300(190)	4	5.2
540	575.5	400(290)	5	5.8
640	675.5	500(390)	6	6.4
740	775.5	600(490)	7	7.0
840	875.5	700(590)	8	7.6
940	975.5	800(690)	9	8.1

Notes (1) The value indicates the allowable stroke when limit sensors are mounted. The value in ( ) represents dimension for two slide tables in close contact.

(2) The value shows the mass of the entire table with one slide table, and it is 0.6kg heavier with two slide tables.

Remarks 1. Parts for motor attachment are appended, and this figure indicates a finished state after assembled by the customer.

2. If folded back to right and left, motor attachment is about 8mm lower than the bottom of the bed.

3. If folded back upward, motor attachment is about 6mm lower than the bottom of the bed.