

U.S. PATENTED

IKO

Precision Positioning Table

TU

The Solution for various automation needs...

IKO NIPPON THOMPSON CO., LTD.

CAT-57174



See you again at
IKO Website
<http://www.ikont.co.jp/eg/>

U-Shaped track rail

Large increase in rigidity and stable high accuracy have been realized!

IKO

Precision Positioning Table



INDEX

Specification	Feature of TU	A-3 ~	A
	Identification Number and Specification	A-7 ~	
	Accuracy	A-12 ~	
	Maximum speed	A-14 ~	
	Maximum Load Mass	A-16 ~	
	Specification of Linear Motion Rolling Guide	A-22 ~	
	Specification of Ball Screw	A-23 ~	
	Rigidity	A-25 ~	
	Table Inertia and Starting Torque	A-26 ~	
	Cover Specification	A-29 ~	
	Sensor Specification	A-31 ~	
	Motor Folding Back Specification	A-37 ~	
	C-Lube Plate Specification	A-38 ~	
Dimension	Dimension Table of TU 25	B-1 ~	B
	Dimension Table of TU 30	B-2 ~	
	Dimension Table of TU 40	B-3 ~	
	Dimension Table of TU 50	B-5 ~	
	Dimension Table of TU 60	B-9 ~	
	Dimension Table of TU 86	B-13 ~	
	Dimension Table of TU 100	B-18 ~	
	Dimension Table of TU 130	B-19 ~	
Electric devices	Dimension of Motor and Attachment	C-1 ~	C
	Motor attachment for NEMA specification	C-5 ~	
	Specification of Motor and Driver	C-7 ~	
	System configuration	C-17 ~	
	Specification of Controller	C-20 ~	
How to use	Examination of operating pattern	D-1 ~	D
	Installation of TU	D-4 ~	
	XY Bracket	D-5 ~	
	Lubrication	D-7 ~	
	Precaution on use	D-8 ~	
	Type and Classification of IKO Precision Positioning Tables	D-9 ~	
	Selection of IKO Precision Positioning Tables	D-15 ~	
	Application	D-24 ~	
Application sheet	D-35 ~		

High Rigidity



TU (Standard type)

IKO Precision Positioning Table **TU**

IKO Precision Positioning Table TU is a compact and slim type positioning table with a slide table assembled inside a U-shaped track rail.

The slide table is an integral part of a linear motion rolling guide mechanism, in which large diameter steel balls are arranged in two rows and make four-point contact with the raceways. Stable high accuracy and rigidity can thus be obtained even under loads fluctuating in direction and magnitude or complex loads. Also, by adopting a U-shaped structure, the rigidity of the track rail under moment load and torsion is greatly increased.

IKO Precision Positioning Table TU comes in eight sizes, with a track rail width ranging from 25 mm to 130 mm. For each of them, slide tables with different lengths are available. Also, the type and lead of ball screw, motor type, sensor installation specifications, etc. can be selected to obtain the optimal positioning table for each specific application.



Low profile

TU...Y (Low profile type)

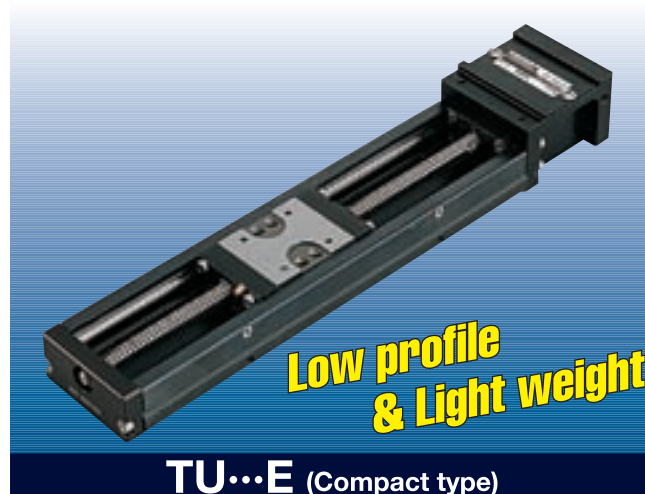

Low profile & Light weight

TU...E (Compact type)

Features of **IKO** Precision Positioning Table **TU**

- 1 Extra rigid U-shaped track rail is adopted.**
By adopting a U-shaped track rail, the rigidity of the track rail under moment load and torsion is greatly increased.
- 2 Abundant sizes**
IKO precision positioning Table TU comes in eight sizes, with a track rail width ranging from 25 mm to 130 mm.
- 3 Abundant options**
The type and lead of ball screw, motor type, sensor installation specifications, surface treatment specifications, bellows specification, etc. can be selected. Thus, IKO Positioning Table TU can be used for a variety of applications, or many kinds of usage.
- 4 Lubrication part C-Lube plate can be applied.**
By adopting C-Lube plate to slide unit and ball screw, re-lubrication interval can be made longer, and maintenance and inspection time can be reduced.

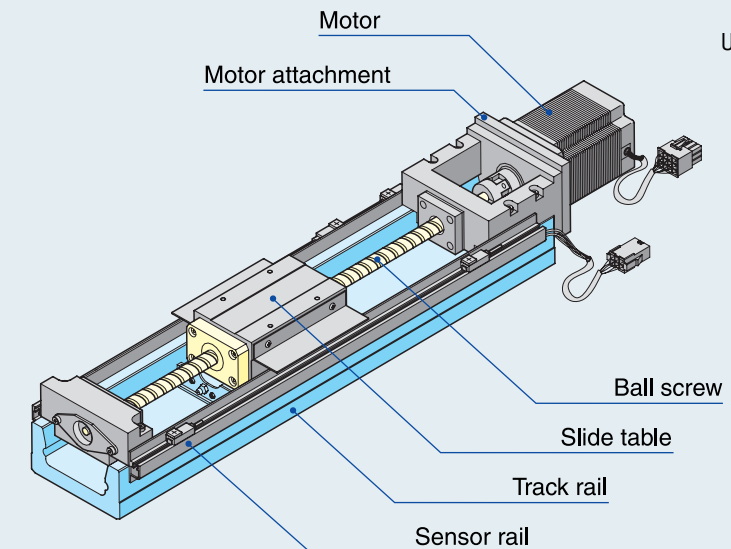

U.S. PATENT No. 5,967,667
No. 6,082,899
No. 6,176,617
No. 6,240,796
No. 6,517,244
No. 6,634,246

Structure of Precision Positioning Table TU

Note: The specifications and dimensions of products in this catalog are subject to change without prior notice.

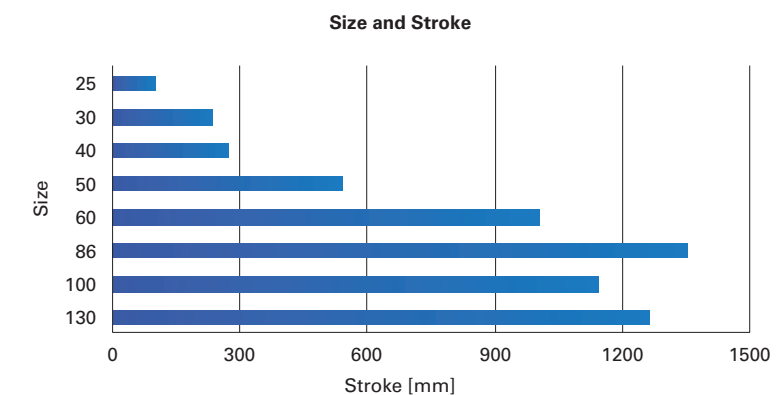

1N=0.102kgf=0.2248lbs.
1mm=0.03937inch

Simple and easy ordering

Just specify the identification number for the required functions and performance.



Slide table types and lengths

Slide tables with three different lengths, namely, short, standard, and long, are available with the same sectional shape. A bridge cover and/or X-Y bracket can be attached to the flange type table.

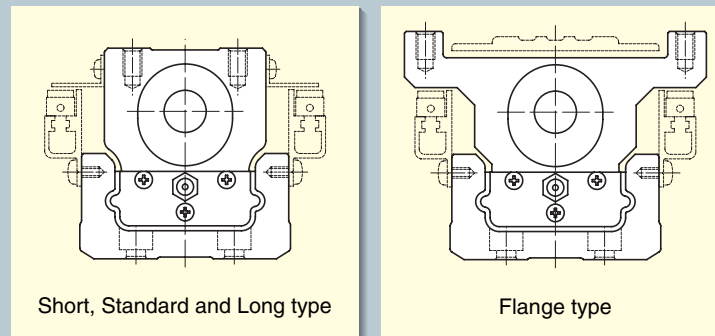

Motor folding back specification

The table with a motor folding back specification is effective in space-saving because the overall length of the table can be shortened.

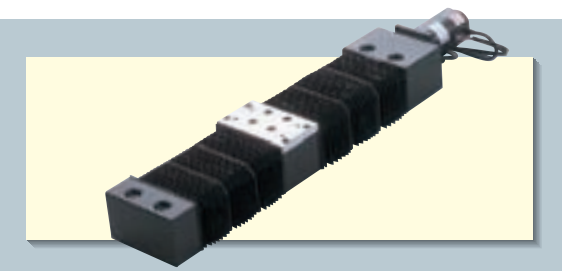

Table with bridge cover

A bridge cover can be attached to the flange type tables.

Table with bellows

A series of tables with bellows is available for preventing foreign matter from intruding into the table.



Precision Positioning Table with C-Lube plate

When C-Lube plates that apply lubrication oil are attached, re-lubrication interval of ball screw and Linear Motion Rolling Guide can be made longer, and maintenance and inspection time can be reduced.



Black chrome surface treatment

A black permeable film is applied on the surfaces of slide table, track rail, and ball screw to improve corrosion resistance.

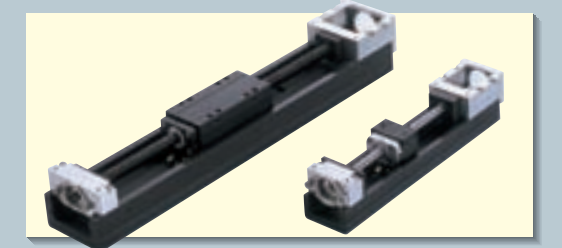

X-Y bracket

A series of X-Y brackets is prepared. The X-Y brackets can be used for assembling X-Y tables in any desired configuration.

Number of slide tables

Two slide tables can be mounted on a track rail in applications where the magnitude of applied load/or moment is large.

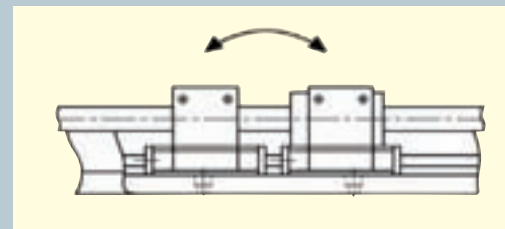

Motor types

Either stepping motor or AC servo motor can be selected. A motor with brake can also be specified for a vertical shaft application.

Ball screw types and leads

Either rolled screw or ground screw can be selected according to the accuracy requirement. The ball screw lead can also be specified. A table without a ball screw can be used as a follower table within a set of two parallel positioning tables.

Sensor installation specifications

Various sensors including limit sensors and origin sensors are available for installation.

A

Identification Number and Specification

Example of identification number

TU 86 FG 89 A / Y029 G 10 S 0 0 R Q

Type

- ① Model
- ② Slide table shape

Size

- ③ Size

Part code

- ④ Track rail length
- ⑤ Number of slide tables

Motor code

- ⑥ With or without motor
- ⑦ Motor type

Ball screw code

- ⑧ Ball screw type
- ⑨ Ball screw lead

Cover code

- ⑩ Cover specification

Sensor code

- ⑪ Sensor installation specification

Surface treatment code

- ⑫ Surface treatment specification

Motor folding back code

- ⑬ Motor folding back specification

C-Lube plate code

- ⑭ C-Lube plate specification

Type

① Model	TU : Precision Positioning Table TU TU...Y : Low Profile Type Precision Positioning Table TU TU...E : Compact Type Precision Positioning Table TU
② Slide table shape For applications, see Table 1.	C : Short table S : Standard table G : Long table FC : Flange type short table F : Flange type standard table FG : Flange type long table

Size

③ Table size For applications, see Table 1.	25, 30, 40, 50, 60, 86, 100, 130
--	----------------------------------

Table 1 Combination of slide table shapes and sizes

Model	Shape								
	TU...C	TU...S	TU...G	TU...FC	TU...F	TU...FG	TU...YF	TU...ES	TU...EF
TU 25	—	○	—	—	○	—	—	—	—
TU 30	—	○	—	—	○	—	—	—	—
TU 40	○	○	○	—	○	—	—	—	—
TU 50	○	○	○	—	○	—	○	○	○
TU 60	○	○	○	○	○	○	○	○	○
TU 86	○	○	○	○	○	○	○	—	—
TU100	—	○	—	—	○	—	—	—	—
TU130	—	○	—	—	○	—	—	—	—

Part code

④ Track rail length For applications, see Table 2.1, and Table 2.2.	Specify the track rail length in cm.	
⑤ Number of slide tables	S : 1 C : 2	Specify the number of tables. For Low profile type, only code "S" is available.

Table 2.1 Track rail length

unit : mm
[] : Length code

Model	Track rail length [Length code]										
TU 25	[13] 130	[16] 165	[20] 200	—	—	—	—	—	—	—	—
TU 30	[14] 140	[18] 180	[22] 220	[26] 260	[30] 300	[34] 340	—	—	—	—	—
TU 40	[18] 180	[24] 240	[30] 300	[36] 360	[42] 420	—	—	—	—	—	—
TU 50	[22] 220	[30] 300	[38] 380	[46] 460	[54] 540	[62] 620	[70] 700	—	—	—	—
TU 60	[29] 290	[39] 390	[49] 490	[59] 590	[69] 690	[79] 790	[99] 990	[119] 1190	—	—	—
TU 86	[49] 490	[59] 590	[69] 690	[79] 790	[89] 890	[99] 990	[109] 1090	[119] 1190	[139] 1390	[159] 1590	—
TU100	[101] 1010	[116] 1160	[131] 1310	[146] 1460	—	—	—	—	—	—	—
TU130	[101] 1010	[116] 1160	[131] 1310	[146] 1460	[161] 1610	—	—	—	—	—	—
TU50Y	[24] 240	[32] 320	[40] 400	—	—	—	—	—	—	—	—
TU60Y	[40] 400	[50] 500	[60] 600	—	—	—	—	—	—	—	—
TU86Y	[40] 400	[60] 600	[80] 800	—	—	—	—	—	—	—	—
TU50E	[15] 150	[20] 200	[25] 250	[30] 300	—	—	—	—	—	—	—
TU60E	[15] 150	[20] 200	[30] 300	[40] 400	[50] 500	[60] 600	[70] 700	[75] 750	—	—	—

Remarks 1 : For the stroke length, see the dimension table on and after page B-1.

2 : For the motor folding back specification, see Table 2.2.

Table 2.2 Track rail length of TU (Motor folding back specification)

unit : mm
[] : Length code

Model	Track rail length [Length code]									
TU 40	[14] 140	[20] 200	[26] 260	[32] 320	[38] 380	—	—	—	—	—
TU 50	[18] 180	[26] 260	[34] 340	[42] 420	[50] 500	[58] 580	[66] 660	—	—	—
TU 60	[24] 244	[34] 344	[44] 444	[54] 544	[64] 644	[74] 744	—	—	—	—
TU 86	[44] 442	[54] 542	[64] 642	[74] 742	[84] 842	[94] 942	[104] 1042	[114] 1142	—	—

Remark : For the stroke length, see the dimension table on and after page B-1.

Motor code

Electric Device⇒P.C-1

⑥With or without motor	No symbol : Without motor A : With motor	If the motor is prepared on the customer side, specify "Without motor". (no symbol)
⑦Motor type For applications, see Table 3.	No symbol : Without motor attachment and coupling	When "Without motor" (no symbol) is selected in item ⑥, · Motor attachment and coupling applicable to the selected motor are mounted at delivery. · When Motor attachment and coupling are not necessary, please specify "No symbol". (See specification after C-1)

Table 3 Motor code

Type of motor	TU Size	Without brake		With brake		Motor brand	
		Motor code	Motor part number	Motor code	Motor part number		
AC servo motor	TU 25 TU 30	AL6	SGMM-A2C312	AL6B	SGMM-A2C312C	Yasukawa Electric	
		HL6	HC-AQ0235D	HL6B	HC-AQ0235BD	Mitsubishi Electric	
	TU 40 TU 50	Y027	SGMAH-A5AAA21-E	Y032	SGMAH-A5AAA2C-E	Yasukawa Electric	
		P001	MSMA5AZA1A	P006	MSMA5AZA1B	Panasonic	
	TU 60	J001	HC-KFS053	J006	HC-KFS053B	Mitsubishi Electric	
		Y028	SGMAH-01AAA21-E	Y033	SGMAH-01AAA2C-E	Yasukawa Electric	
		P002	MSMA012A1A	P007	MSMA012A1B	Panasonic	
	TU 86	J002	HC-KFS13	J007	HC-KFS13B	Mitsubishi Electric	
		Y029	SGMAH-02AAA21-E	Y034	SGMAH-02AAA2C-E	Yasukawa Electric	
		P003	MSMA022A1A	P008	MSMA022A1B	Panasonic	
	TU100	J003	HC-KFS23	J008	HC-KFS23B	Mitsubishi Electric	
		Y030	SGMAH-04AAA21-E	Y035	SGMAH-04AAA2C-E	Yasukawa Electric	
		P004	MSMA042A1A	P009	MSMA042A1B	Panasonic	
	TU130	J004	HC-KFS43	J009	HC-KFS43B	Mitsubishi Electric	
		Y031	SGMAH-08AAA21-E	Y036	SGMAH-08AAA2C-E	Yasukawa Electric	
		P005	MSMA082A1A	P010	MSMA082A1B	Panasonic	
	Stepper motor	TU 25 TU 30	V004	PK523PA	—	—	Oriental motor
		TU 40 TU 50	V005	PK545AW	V006	PK545AWM	
		TU 60 TU 86	V011	PK569AE	V012	PK569AEM	
		TU100 TU130	V015	PK599AE	V016	PK599AEM	

Ball screw code

Ball screw specifications⇒P.A-23

③Ball screw type For applications, see Table 4.	No symbol : Rolled screw G : Ground screw N : Without ball screw	When N is selected, · Select "No symbol" in items ③, ⑦, ⑨, and ⑩. · For sensor installation specification in ⑪, select "Without sensor" (select 0). · "With bellows" cannot be selected in item ⑩. For Low profile type, and Compact type, only "Rolled screw" (No symbol) is available.
⑨Ball screw lead	4, 5, 8, 10, 20, 25	

Table 4 Ball screw leads

Model	Ball screw type	Ball screw lead mm													
		TU						TU...Y			TU...E				
		4	5	8	10	20	25	5	10	20	2	4	10		
TU 25	Ground screw	○	—	—	—	—	—	—	—	—	—	—	—	—	—
TU 30	Ground screw	—	○	—	—	—	—	—	—	—	—	—	—	—	—
TU 40	Ground screw	○	—	○	—	—	—	—	—	—	—	—	—	—	—
TU 50	Rolled screw	—	○	—	○	—	—	○	○	—	○	—	—	—	—
	Ground screw	—	○	—	○	—	—	—	—	—	—	—	—	—	—
TU 60	Rolled screw	—	○	—	○	—	—	○	○	—	—	○	○	—	—
	Ground screw	—	○ ⁽¹⁾	—	○ ⁽¹⁾	○ ⁽¹⁾	—	—	—	—	—	—	—	—	—
TU 86	Rolled screw	—	—	—	○ ⁽²⁾	○ ⁽²⁾	—	—	○	○	—	—	—	—	—
	Ground screw	—	—	—	○ ⁽²⁾	○	—	—	—	—	—	—	—	—	—
TU100	Ground screw	—	—	—	—	○	—	—	—	—	—	—	—	—	—
TU130	Ground screw	—	—	—	—	—	○	—	—	—	—	—	—	—	—

Note⁽¹⁾ : Not applicable to track rail lengths 990mm and 1190mm.
⁽²⁾ : Not applicable to track rail lengths 1390mm and 1590mm.

Cover code

Cover specification⇒P.A-29

⑩Cover	0 : Without cover C : With bridge cover (Applicable to TU...FC, TU...F, TU...FG, TU...YF, and TU...EF) J : With bellows (Applicable to TU60S and TU86S)	When "With bellows" (select J) is selected, · Select code S (one side unit) for Number of slide tables in item ⑤. For track rail lengths 1190mm of TU60 and 1590mm of TU86, "With bridge cover" is not available. For Low profile type, only "With bridge cover" (code "C") is available. And black chrome surface treatment is applied to its bridge cover.
---------------	---	---

Sensor code

Sensor specification⇒P.A-31

⑪Sensor	0 : Without sensor and without sensor rail 2 : Two sensors (limit sensors) and with sensor rails 3 : Three sensors (limit and pre-origin sensors) and with sensor rails 4 : Four sensors (limit, pre-origin, and origin sensors) and with sensor rails 9 : Without sensor and with sensor rails	Specify the number of sensors and whether or not to attach the sensor rail to fix the sensors. For Low profile type, four sensors specification (code "4") is not available.
----------------	---	---

Surface treatment code

⑫Surface treatment	No symbol : No treatment R : Black chrome surface treatment "R" Black chrome surface treatment is applied to the surface of the slide table and the track rail. L : Black chrome surface treatment "L" In addition to black chrome surface treatment "R", the treatment is applied to the ball screw shaft and the nut.	Specify the surface treatment specification. A black permeable film is applied to the surface to increase corrosion resistance. For Compact type, only "No symbol" is available. For Compact type, Black oxide surface treatment is already applied to the surface of slide table and the track rail with "No symbol".
---------------------------	---	--

Motor folding back code

Motor folding back specification⇒P.A-37

Motor folding back For applications, see Table 5	No symbol : Without motor folding back U : Upward Motor folding back S : Downward Motor folding back M : Motor folding back to right H : Motor folding back to left T : Without Motor folding back unit	When the Motor folding back is selected (U, S, M or H is selected), · Specify “With motor” (specify A) in item ⑥ · Only AC servo motor is applicable to sizes 60 and 86. When “Without Motor folding back unit” is selected (code : T), · Specify “No symbol” in items ⑥ and ⑦. For Low profile type, and Compact type, only “No symbol” is available.
--	--	---

Table 5 Motor folding back specification

Model	Motor folding back specification ⁽¹⁾		Without motor folding back unit ⁽²⁾
	AC servo motor	Stepping motor	
TU 25	—	—	—
TU 30	—	—	—
TU 40	○	○	○
TU 50	○	○	○
TU 60	○	—	○
TU 86	○	—	○
TU100	—	—	—
TU130	—	—	—

Note⁽¹⁾ : Applicable to symbols U, S, M, and H.
 Note⁽²⁾ : Applicable to symbol T.

C-Lube plate code

C-Lube plate specification⇒P.A-38

C-Lube plate For applications, see Table 6	No symbol : Without Capillary plate Q : With Capillary plate	When Q is selected, · Specify “Ground screw” (G) or “Without ball screw” (N) in item ③. For Low profile type, and Compact type, “With Capillary plate” (Q) is not available.
--	---	--

Table 6 Applicable size of C-Lube plate

Model	Rolled ball screw	Ground ball screw	Without ball screw
TU 25	—	—	—
TU 30	—	—	—
TU 40	—	○	○
TU 50	—	○	○
TU 60 ⁽¹⁾	—	○	○
TU 86 ⁽²⁾	—	○	○
TU100	—	○	○
TU130	—	○	○

Note⁽¹⁾ : Not applicable to track rail length 990mm and 1190mm of TU60.
 Note⁽²⁾ : In TU86, when track rail length 1390mm or 1590mm is required, please consult  for further information.

Accuracy

Accuracy of  Precision Positioning Table TU depends on the types of ball screw specified. Accuracy of TU with ground ball screw is shown in Table 7.1. Accuracies of TU with rolled ball screw are shown in Table 7.2 and 7.3. Definition of accuracy and measuring method are shown in Table 8.

Table 7.1 Accuracy of TU (Ground type ball screw)

unit : mm

Track rail length		Repeatability		Positioning accuracy ⁽¹⁾		Parallelism in table operation B		Backlash ⁽¹⁾
Over	Incl.	Short table	Standard table and long table	Short table	Standard table and long table	Short table	Standard table and long table	
—	400 (350)	±0.004 (±0.020)	±0.002 (±0.020)	0.030	0.020	0.015	0.008	0.003
400 (350)	500 (500)			0.035	0.025		0.020	
500 (500)	600 (550)					0.040		
600 (550)	700 (700)			0.045	0.035		0.025	
700 (700)	800 (800)					0.050		
800 (800)	900 (900)			—	0.045		—	
900 (900)	1000 (1000)					—		
1000 (1000)	1100 (1100)			—	—		—	
1100 (1100)	1200					—		
1200	1400			—	—		—	
1400	1500					—		
1500	1610	—	—	—	—			

Note⁽¹⁾ : Not applicable to tables of motor folding back specification.

Remarks 1 : The values in () are applicable to tables of motor folding back specification.

2 : The accuracy for tables of motor folding back specification are applicable provided that the tension in the timing belt is appropriately adjusted.

Table 7.2 Accuracy of TU and TU...Y (Rolled type ball screw)

unit : mm

Track rail length		Repeatability	Parallelism in table operation B	Backlash ⁽¹⁾
Over	Incl.			
—	500	±0.025 (±0.040)	0.015	0.050
500	800		0.020	
800	1200		0.025	

Note⁽¹⁾ : Not applicable to tables of motor folding back specification.

Remarks 1 : The values in () are applicable to tables of motor folding back specification.

2 : The accuracy for tables of motor folding back specification are applicable provided that the tension in the timing belt is appropriately adjusted.

Table 7.3 Accuracy of TU...E (Rolled type ball screw)

unit : mm

Track rail length	Repeatability	Parallelism in table operation B	Backlash
150	±0.010	0.015	0.020
200			
300			
400			
500			
600	0.025	0.025	0.020
700			
750			

Maximum Speed

Table 8 Definition of accuracy and measuring method

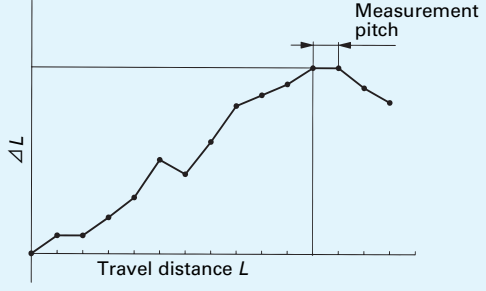
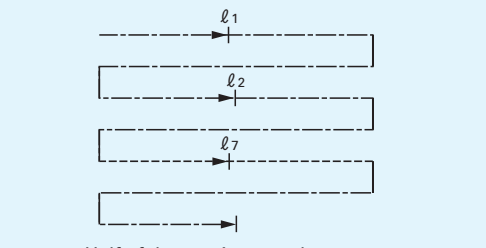
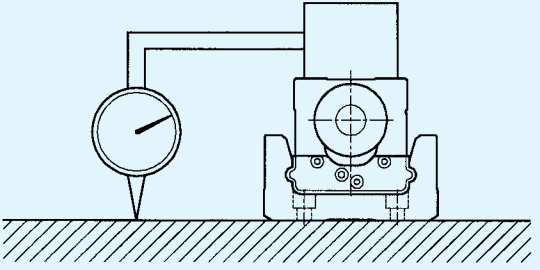
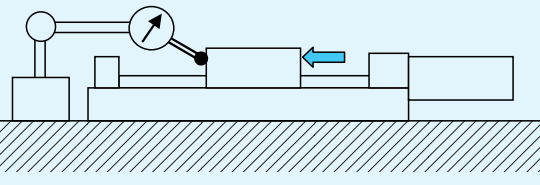
<p>Positioning accuracy</p> <p>Perform positioning in sequence from the reference position in a certain direction. Measure a difference between the actual travel distance and the specified travel distance at each position. The maximum difference among measured distances within the stroke length is indicated in an absolute value.</p>	 <p>Reference position</p> <p>$\Delta L = (\text{actual travel distance}) - (\text{command value of travel distance})$</p>
<p>Repeatability</p> <p>Perform positioning 7 times repeatedly from the same direction for an optional point and measure the stop position. Obtain a half of the maximum difference in reading. On the basis of the above measurement, perform positioning in the center of the stroke length and each of the ends. Adopt the maximum value among obtained values as the measured value. The sign ± is attached to the half of the maximum difference.</p>	 <p>Half of the maximum value among measured values l_1, l_2, \dots, l_7</p>
<p>Parallelism in operation B</p> <p>This means the parallelism (indicator movement) between slide table operation and plane (table mounting surface). Fix the indicator in the center of the slide table. Apply the test indicator onto the surface of the mounting base and perform a measurement over almost all the range of stroke length. Then, adopt the maximum difference in reading as the measured value.</p>	 <p>Parallelism in table operation B (In full stroke length)</p>
<p>Backlash</p> <p>Apply a feed to the slide table. Read the test indicator at a slight travel. Adopt this value as the reference value. Move the slide table with the specified load in the same direction in this status without using any feed unit and obtain a difference from the reference value when the load is removed. Perform this measurement at the center and each of the ends of the stroke, and adopt the maximum value among obtained values as the measured value.</p>	

The maximum speeds of Precision Positioning Table TU are shown in Table 9.1 and Table 9.2. The actual maximum speeds must be determined by examining the operating pattern considering the motor type used, load conditions, etc. Note that the ball screw drive type may be limited by the allowable rotation speed of the ball screw depending on the stroke length.

$$\text{Maximum speed (mm/s)} = \text{Ball screw lead (mm)} \times \frac{\text{Maximum rotation speed of motor (r/min)}}{60}$$

To obtain the actual positioning time, it is necessary to examine the operation pattern according to conditions such as acceleration/deceleration time and stroke length. Refer to "Examination of operation pattern." shown in page E-1.

Table 9.1 Maximum speed (AC servo motor)

Motor type	Model	Track rail length mm	Motor speed r/min	Maximum speed mm/s						
				Lead 2mm	Lead 4mm	Lead 5mm	Lead 8mm	Lead 10mm	Lead 20mm	Lead 25mm
AC servo motor	TU 25	200 or less	3000	—	200	—	—	—	—	—
	TU 30	340 or less	3000	—	—	250	—	—	—	—
	TU 40	—	3000	—	200	—	400	—	—	—
	TU 50 (Y)	—	3000	—	—	250	—	500	—	—
	TU 60 (Y)	690 or less	3000	—	—	250	—	500	1000	—
		790	2910	—	—	243	—	485	970	—
		990	1940	—	—	162	—	323	—	—
	TU 86 (Y)	1190	1290	—	—	108	—	215	—	—
		790 or less	3000	—	—	—	—	500	1000	—
		890	2760	—	—	—	—	460	920	—
		990	2180	—	—	—	—	363	727	—
		1090	1770	—	—	—	—	295	590	—
	TU100	1190	1460	—	—	—	—	243	487	—
		1390	1610	—	—	—	—	—	537	—
		1590	1200	—	—	—	—	—	400	—
		1010	3000	—	—	—	—	—	1000	—
	TU130	1160	2320	—	—	—	—	—	773	—
		1310	1780	—	—	—	—	—	593	—
		1460	1400	—	—	—	—	—	467	—
		1010	2690	—	—	—	—	—	—	1121
1160		2690	—	—	—	—	—	—	1121	
TU50E	1310	2190	—	—	—	—	—	—	913	
	1460	1720	—	—	—	—	—	—	717	
	1610	1390	—	—	—	—	—	—	579	
TU60E	300 or less	3000	100	—	—	—	—	—	—	
	600 or less	3000	—	200	—	—	500	—	—	
	700	2550	—	170	—	—	425	—	—	
	750	2280	—	—	—	—	380	—	—	



Maximum Load Mass

Table 9.2 Maximum speed (Stepper motor)

Motor type	Model	Track rail length mm	Motor speed r/min	Maximum speed mm/s						
				Lead 2mm	Lead 4mm	Lead 5mm	Lead 8mm	Lead 10mm	Lead 20mm	Lead 25mm
Stepper motor	TU 25	200 or less	1800	—	120	—	—	—	—	—
	TU 30	340 or less	1800	—	—	150	—	—	—	—
	TU 40	—	1800	—	120	—	240	—	—	—
	TU 50	—	1800	—	—	150	—	300	—	—
	TU 60	790 or less	1800	—	—	—	—	—	600	—
		990 or less	1800	—	—	150	—	300	—	—
		1190	1290	—	—	108	—	215	—	—
	TU 86	990 or less	1800	—	—	—	—	300	600	—
		1090	1770	—	—	—	—	295	590	—
		1190	1460	—	—	—	—	243	487	—
		1390	1610	—	—	—	—	—	537	—
		1590	1200	—	—	—	—	—	400	—
	TU100	1160 or less	1800	—	—	—	—	—	600	—
		1310	1780	—	—	—	—	—	593	—
		1460	1400	—	—	—	—	—	467	—
	TU130	1310 or less	1800	—	—	—	—	—	—	750
		1460	1720	—	—	—	—	—	—	717
		1610	1390	—	—	—	—	—	—	579
	TU50E	300 or less	1800	100	—	—	—	—	—	—
	TU60E	750 or less	1800	—	120	—	—	300	—	—

Maximum load masses of JKO Precision Positioning Table TU are shown in following Tables. The maximum load mass is a reference value for the maximum mass that can be mounted on a table used in a horizontal position and varies very much depending on the load mass position (Height and length). The maximum load masses are obtained by calculating the mass for which the rating life of the ball screw or linear motion rolling guide becomes 18,000 hours when the table is operated continuously at the maximum speed (for each size), and 0.2s each, at acceleration, and at deceleration.

Table 10.1 Maximum load mass

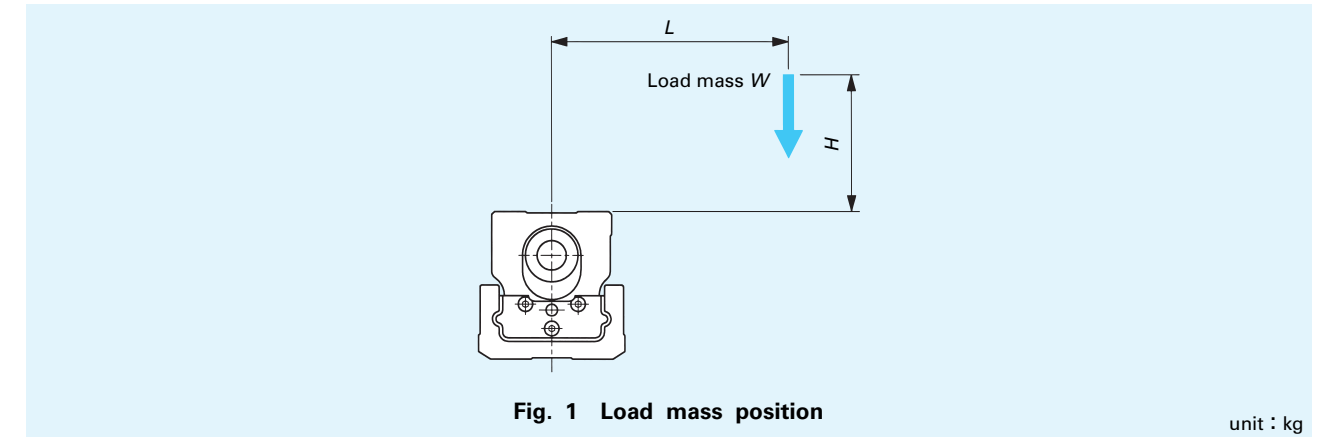

Model	Type of screw	Lead of screw mm	Slide table length	Height H mm	Length L mm									
					0	100	200	300	400	500	600	800	1000	
TU25	Ground screw	4	Standard	0	17	1.3	0.68	—	—	—	—	—	—	—
				200	3.8	1.1	0.62	—	—	—	—	—	—	
				400	2.1	0.90	0.56	—	—	—	—	—	—	
				600	1.5	0.76	0.50	—	—	—	—	—	—	
TU30	Ground screw	5	Standard	0	21	1.9	1.0	0.69	0.52	—	—	—	—	
				200	4.5	1.5	0.89	0.63	—	—	—	—	—	
				400	2.5	1.2	0.78	0.58	—	—	—	—	—	
				600	1.7	1.0	0.70	0.53	—	—	—	—	—	
TU40	Ground screw	4	Short	0	58	7.8	4.2	2.8	2.2	1.7	1.5	1.1	—	
				200	13	5.6	3.5	2.5	2.0	1.6	1.4	1.0	—	
				400	7.5	4.3	2.9	2.2	1.8	1.5	1.3	1.0	—	
				600	5.2	3.4	2.5	2.0	1.6	1.4	1.2	1.0	—	
			Standard	0	87	11	6.0	4.1	3.1	2.5	2.1	1.6	1.3	—
				200	25	8.9	5.3	3.8	2.9	2.4	2.0	1.5	1.2	—
				400	15	7.2	4.7	3.5	2.7	2.3	1.9	1.5	1.2	—
				600	10	6.0	4.2	3.2	2.6	2.1	1.8	1.4	1.2	—
			Long	0	120	15	8.2	5.6	4.3	3.4	2.9	2.2	1.7	—
				200	44	13	7.5	5.3	4.1	3.3	2.8	2.1	1.7	—
				400	26	11	6.9	5.0	3.9	3.2	2.7	2.1	1.7	—
				600	19	9.6	6.3	4.7	3.7	3.1	2.6	2.0	1.6	—
		8	Short	0	37	5.4	2.9	2.0	1.5	1.2	1.0	—	—	
				200	5.7	3.1	2.1	1.6	1.3	1.1	—	—	—	
				400	3.1	2.1	1.6	1.3	1.1	—	—	—	—	
				600	2.1	1.6	1.3	1.1	—	—	—	—	—	
			Standard	0	46	8.1	4.4	3.0	2.3	1.8	1.5	1.2	—	
				200	11	5.3	3.4	2.5	2.0	1.6	1.4	1.1	—	
				400	6.1	3.9	2.8	2.2	1.8	1.5	1.3	1.0	—	
				600	4.2	3.0	2.3	1.9	1.6	1.4	1.2	1.0	—	
Long	0	46	11	6.1	4.2	3.2	2.6	2.1	1.6	1.3				
	200	20	8.3	5.1	3.7	2.9	2.4	2.0	1.5	1.3				
	400	11	6.4	4.4	3.3	2.6	2.2	1.9	1.5	1.2				
	600	7.8	5.1	3.8	3.0	2.4	2.1	1.8	1.4	1.2				

Table 10.2 Maximum load mass

unit : kg

Model	Type of screw	Lead of screw mm	Slide table length	Height H mm	Length L mm								
					0	100	200	300	400	500	600	800	1000
TU50	Ground screw	5	Short	0	75	13	6.9	4.8	3.6	2.9	2.5	1.9	1.5
				200	17	8.4	5.5	4.0	3.2	2.6	2.3	1.7	1.4
				400	9.8	6.2	4.5	3.5	2.8	2.4	2.1	1.6	1.3
				600	6.8	4.9	3.7	3.0	2.5	2.2	1.9	1.5	1.3
			Standard	0	130	21	11	7.7	5.8	4.7	4.0	3.0	2.4
				200	39	16	9.6	6.9	5.4	4.4	3.7	2.9	2.3
		400		23	12	8.3	6.2	5.0	4.2	3.6	2.8	2.3	
		600		16	10	7.3	5.7	4.6	3.9	3.4	2.6	2.2	
		Long	0	140	29	16	11	8.2	6.6	5.6	4.2	3.4	
			200	71	24	14	10	7.8	6.4	5.4	4.1	3.3	
			400	43	20	13	9.4	7.4	6.1	5.2	4.0	3.2	
			600	31	17	12	8.8	7.0	5.8	5.0	3.9	3.2	
	10	Short	0	44	8.4	4.6	3.2	2.4	2.0	1.7	1.2	1.0	
			200	7.4	4.4	3.1	2.4	1.9	1.6	1.4	1.1	—	
			400	4.0	2.9	2.3	1.9	1.6	1.4	1.2	1.0	—	
			600	2.8	2.2	1.8	1.6	1.4	1.2	1.1	—	—	
		Standard	0	44	15	8.0	5.5	4.2	3.4	2.8	2.1	1.7	
			200	17	9.0	6.0	4.5	3.6	3.0	2.5	2.0	1.6	
	Long	0	44	21	12	8.0	6.1	4.9	4.1	3.1	2.5		
		200	33	15	9.5	6.9	5.5	4.5	3.8	2.9	2.4		
		400	19	11	7.9	6.1	4.9	4.1	3.6	2.8	2.3		
		600	13	8.9	6.7	5.4	4.5	3.8	3.3	2.6	2.2		
	Rolled screw	5	Short	0	75	13	6.9	4.8	3.6	2.9	2.5	1.9	1.5
				200	17	8.4	5.5	4.0	3.2	2.6	2.3	1.7	1.4
400				9.8	6.2	4.5	3.5	2.8	2.4	2.1	1.6	1.3	
600				6.8	4.9	3.7	3.0	2.5	2.2	1.9	1.5	1.3	
Standard			0	120	21	11	7.7	5.8	4.7	4.0	3.0	2.4	
			200	39	16	9.6	6.9	5.4	4.4	3.7	2.9	2.3	
		400	23	12	8.3	6.2	5.0	4.2	3.6	2.8	2.3		
		600	16	10	7.3	5.7	4.6	3.9	3.4	2.6	2.2		
Long		0	120	29	16	11	8.2	6.6	5.6	4.2	3.4		
		200	71	24	14	10	7.8	6.4	5.4	4.1	3.3		
		400	43	20	13	9.4	7.4	6.1	5.2	4.0	3.2		
		600	31	17	12	8.8	7.0	5.8	5.0	3.9	3.2		
10	Short	0	45	8.4	4.6	3.2	2.4	2.0	1.7	1.2	1.0		
		200	7.4	4.4	3.1	2.4	1.9	1.6	1.4	1.1	—		
		400	4.0	2.9	2.3	1.9	1.6	1.4	1.2	1.0	—		
		600	2.8	2.2	1.8	1.6	1.4	1.2	1.1	—	—		
	Standard	0	47	15	8.0	5.5	4.2	3.4	2.8	2.1	1.7		
		200	17	9.0	6.0	4.5	3.6	3.0	2.5	2.0	1.6		
Long	0	47	21	12	8.0	6.1	4.9	4.1	3.1	2.5			
	200	33	15	9.5	6.9	5.5	4.5	3.8	2.9	2.4			
	400	19	11	7.9	6.1	4.9	4.1	3.6	2.8	2.3			
	600	13	8.9	6.7	5.4	4.5	3.8	3.3	2.6	2.2			

Table 10.3 Maximum load mass

unit : kg

Model	Type of screw	Lead of screw mm	Slide table length	Height H mm	Length L mm									
					0	100	200	300	400	500	600	800	1000	
TU60	Ground screw	5	Short	0	100	19	11	7.3	5.6	4.5	3.8	2.9	2.3	
				200	27	13	8.5	6.3	5.0	4.1	3.5	2.7	2.2	
				400	16	9.7	7.0	5.4	4.4	3.7	3.2	2.5	2.1	
				600	11	7.7	5.9	4.8	4.0	3.4	3.0	2.4	2.0	
			Standard	0	160	31	17	12	9.0	7.3	6.1	4.6	3.7	
				200	61	24	15	11	8.4	6.9	5.8	4.5	3.6	
		400		36	19	13	9.7	7.8	6.5	5.5	4.3	3.5		
		600		25	16	11	8.9	7.2	6.1	5.3	4.1	3.4		
		Long	0	160	47	25	18	13	11	9.1	6.9	5.5		
			200	120	39	23	16	13	10	8.8	6.7	5.4		
			400	75	34	21	15	12	10	8.5	6.5	5.3		
			600	54	29	19	15	12	10	9.6	8.2	6.4	5.2	
	10	Short	0	58	13	7.1	4.9	3.8	3.0	2.6	1.9	1.6		
			200	12	6.9	4.9	3.7	3.0	2.6	2.2	1.7	1.4		
			400	6.4	4.7	3.6	3.0	2.5	2.2	1.9	1.6	1.3		
			600	4.4	3.5	2.9	2.5	2.2	1.9	1.7	1.4	1.2		
		Standard	0	58	22	12	8.5	6.5	5.2	4.4	3.3	2.7		
			200	27	14	9.4	7.0	5.6	4.6	4.0	3.1	2.5		
	Long	0	58	34	19	13	9.9	8.0	6.8	5.1	4.1			
		200	57	25	16	12	9.0	7.4	6.3	4.9	3.9			
		400	33	19	13	10	8.2	6.9	5.9	4.6	3.8			
		600	23	15	12	9.1	7.5	6.4	5.6	4.4	3.6			
	20	Short	0	29	7.3	3.9	2.7	2.0	1.6	1.4	1.0	—		
			200	4.8	3.2	2.4	1.9	1.6	1.4	1.2	—	—		
400			2.6	2.0	1.7	1.4	1.3	1.1	1.0	—	—			
600			1.8	1.5	1.3	1.1	1.0	—	—	—	—			
Standard		0	29	14	7.9	5.5	4.2	3.4	2.8	2.1	1.7			
		200	11	7.1	5.1	4.0	3.3	2.8	2.4	1.9	1.6			
Long	0	29	24	13	9.1	6.9	5.6	4.7	3.6	2.9				
	200	25	14	9.5	7.2	5.8	4.9	4.2	3.3	2.7				
	400	14	9.6	7.3	5.9	4.9	4.2	3.7	3.0	2.5				
	600	9.5	7.3	5.9	5.0	4.3	3.8	3.3	2.7	2.3				



Table 10.4 Maximum load mass

unit : kg

Model	Type of screw	Lead of screw mm	Slide table length	Height H mm	Length L mm								
					0	100	200	300	400	500	600	800	1000
TU60	Rolled screw	5	Short	0	100	19	11	7.3	5.6	4.5	3.8	2.9	2.3
				200	27	13	8.5	6.3	5.0	4.1	3.5	2.7	2.2
				400	16	9.7	7.0	5.4	4.4	3.7	3.2	2.5	2.1
				600	11	7.7	5.9	4.8	4.0	3.4	3.0	2.4	2.0
			Standard	0	140	31	17	12	9.0	7.3	6.1	4.6	3.7
				200	61	24	15	11	8.4	6.9	5.8	4.5	3.6
				400	36	19	13	9.7	7.8	6.5	5.5	4.3	3.5
				600	25	16	11	8.9	7.2	6.1	5.3	4.1	3.4
			Long	0	140	47	25	18	13	11	9.1	6.9	5.5
				200	120	39	23	16	13	10	8.8	6.7	5.4
				400	75	34	21	15	12	10	8.5	6.5	5.3
				600	54	29	19	15	12	9.6	8.2	6.4	5.2
		10	Short	0	46	13	7.1	4.9	3.8	3.0	2.6	1.9	1.6
				200	12	6.9	4.9	3.7	3.0	2.6	2.2	1.7	1.4
				400	6.4	4.7	3.6	3.0	2.5	2.2	1.9	1.6	1.3
				600	4.4	3.5	2.9	2.5	2.2	1.9	1.7	1.4	1.2
			Standard	0	46	22	12	8.5	6.5	5.2	4.4	3.3	2.7
				200	27	14	9.4	7.0	5.6	4.6	4.0	3.1	2.5
				400	15	10	7.5	5.9	4.9	4.2	3.6	2.9	2.4
				600	11	7.8	6.2	5.1	4.3	3.7	3.3	2.7	2.2
			Long	0	46	34	19	13	9.9	8.0	6.8	5.1	4.1
				200	46	25	16	12	9.0	7.4	6.3	4.9	3.9
				400	33	19	13	10	8.2	6.9	5.9	4.6	3.8
				600	23	15	12	9.1	7.5	6.4	5.6	4.4	3.6

Table 10.5 Maximum load mass

unit : kg

Model	Type of screw	Lead of screw mm	Slide table length	Height H mm	Length L mm										
					0	100	200	300	400	500	600	800	1000		
TU86	Ground screw	10	Short	0	130	33	19	13	10	8.4	7.1	6.1	5.4	4.3	
				200	31	19	13	10	8.4	7.1	6.1	4.8	4.0		
				400	18	13	10	8.3	7.0	6.1	5.4	4.3	3.6		
				600	12	9.8	8.1	6.9	6.0	5.3	4.8	3.9	3.4		
			Standard	0	150	68	39	27	21	17	14	11	8.8		
				200	93	47	31	23	19	15	13	10	8.3		
				400	55	35	26	20	17	14	12	9.6	7.9		
				600	39	28	22	18	15	13	11	9.0	7.5		
			Long	0	150	86	49	34	26	21	18	14	11		
				200	140	64	41	30	24	20	17	13	11		
				400	82	49	35	27	22	18	16	12	10		
				600	59	40	30	24	20	17	15	12	9.7		
		20	Short	0	56	19	11	7.4	5.6	4.6	3.8	2.9	2.3		
				200	13	8.8	6.6	5.3	4.5	3.8	3.4	2.6	2.1		
				400	7.1	5.6	4.7	4.0	3.5	3.1	2.8	2.3	2.0		
				600	4.9	4.1	3.6	3.2	2.9	2.6	2.4	2.0	1.8		
			Standard	0	56	45	26	18	14	11	9.6	7.3	5.9		
				200	41	25	18	14	11	9.6	8.3	6.5	5.4		
				400	23	17	14	11	9.4	8.2	7.2	5.9	4.9		
				600	16	13	11	9.2	8.1	7.1	6.4	5.3	4.5		
			Long	0	56	56	34	24	18	15	12	9.5	7.6		
				200	56	35	25	19	15	13	11	8.6	7.1		
				400	35	25	19	15	13	11	9.8	7.9	6.6		
				600	25	19	16	13	11	9.9	8.8	7.2	6.1		
		Rolled screw	10	Short	0	120	33	19	13	10	8.4	7.1	6.1	5.4	4.3
					200	31	19	13	10	8.4	7.1	6.1	4.8	4.0	
					400	18	13	10	8.3	7.0	6.1	5.4	4.3	3.6	
					600	12	9.8	8.1	6.9	6.0	5.3	4.8	3.9	3.4	
				Standard	0	120	68	39	27	21	17	14	11	8.8	
					200	93	47	31	23	19	15	13	10	8.3	
					400	55	35	26	20	17	14	12	9.6	7.9	
					600	39	28	22	18	15	13	11	9.0	7.5	
				Long	0	120	86	49	34	26	21	18	14	11	
					200	120	64	41	30	24	20	17	13	11	
					400	82	49	35	27	22	18	16	12	10	
					600	59	40	30	24	20	17	15	12	9.7	
		20	Short	0	48	19	11	7.4	5.6	4.6	3.8	2.9	2.3		
				200	13	8.8	6.6	5.3	4.5	3.8	3.4	2.6	2.1		
				400	7.1	5.6	4.7	4.0	3.5	3.1	2.8	2.3	2.0		
				600	4.9	4.1	3.6	3.2	2.9	2.6	2.4	2.0	1.8		
			Standard	0	48	45	26	18	14	11	9.6	7.3	5.9		
				200	41	25	18	14	11	9.6	8.3	6.5	5.4		
				400	23	17	14	11	9.4	8.2	7.2	5.9	4.9		
				600	16	13	11	9.2	8.1	7.1	6.4	5.3	4.5		
			Long	0	48	48	34	24	18	15	12	9.5	7.6		
				200	48	35	25	19	15	13	11	8.6	7.1		
				400	35	25	19	15	13	11	9.8	7.9	6.6		
				600	25	19	16	13	11	9.9	8.8	7.2	6.1		



Specification of Linear Motion Rolling Guide

Load rating of the linear motion rolling guide of Precision Positioning Table TU are shown in Table 11.

Table 10.6 Maximum load mass

unit : kg

Model	Type of screw	Lead of screw mm	Slide table length	Height H mm	Length L mm								
					0	100	200	300	400	500	600	800	1000
TU100	Ground screw	20	Standard	0	80	65	38	27	21	17	14	11	8.7
				200	61	37	27	21	17	14	12	9.7	8.0
				400	35	26	20	17	14	12	11	8.7	7.3
				600	25	20	16	14	12	11	9.6	7.9	6.8
TU130	Ground screw	25	Standard	0	90	84	51	36	28	23	19	15	12
				200	66	44	33	26	22	19	16	13	11
				400	38	30	24	20	18	16	14	11	9.7
				600	27	22	19	17	15	13	12	10	8.8
TU50Y	Rolloed screw	5	Standard	0	120	21	11	7.7	5.8	4.7	4.0	3.0	2.4
				200	39	16	9.6	6.9	5.4	4.4	3.7	2.9	2.3
				400	23	12	8.3	6.2	5.0	4.1	3.6	2.8	2.2
				600	16	10	7.3	5.7	4.6	3.9	3.4	2.6	2.2
	10	Standard	0	47	15	8.0	5.5	4.2	3.4	2.8	2.1	1.7	
			200	17	9.0	6.0	4.5	3.6	3.0	2.5	2.0	1.6	
			400	9.6	6.4	4.7	3.8	3.1	2.6	2.3	1.8	1.5	
			600	6.6	4.9	3.9	3.2	2.7	2.4	2.1	1.7	1.4	
TU60Y	Rolloed screw	5	Standard	0	140	31	17	12	9.0	7.3	6.1	4.6	3.7
				200	60	24	15	11	8.3	6.8	5.8	4.4	3.6
				400	36	19	13	9.7	7.7	6.4	5.5	4.3	3.5
				600	25	16	11	8.8	7.2	6.1	5.2	4.1	3.4
	10	Standard	0	45	22	12	8.4	6.4	5.2	4.4	3.3	2.7	
			200	27	14	9.3	7.0	5.6	4.6	4.0	3.1	2.5	
			400	15	10	7.4	5.9	4.9	4.1	3.6	2.9	2.4	
			600	11	7.8	6.2	5.1	4.3	3.7	3.3	2.7	2.2	
TU86Y	Rolloed screw	10	Standard	0	120	67	39	27	21	17	14	11	8.7
				200	91	47	31	23	18	15	13	10	8.3
				400	55	35	26	20	16	14	12	9.5	7.9
				600	39	28	22	18	15	13	11	9.0	7.5
	20	Standard	0	47	44	26	18	14	11	9.5	7.3	5.9	
			200	40	25	18	14	11	9.5	8.2	6.5	5.3	
			400	23	17	13	11	9.3	8.1	7.2	5.8	4.9	
			600	16	13	11	9.1	8.0	7.1	6.4	5.3	4.5	
TU50E	Rolloed screw	2	Standard	0	61	10	5.5	3.8	2.9	2.3	2.0	1.5	1.2
				200	30	8.9	5.1	3.6	2.8	2.3	1.9	1.5	1.2
				400	19	7.8	4.8	3.4	2.7	2.2	1.9	1.4	1.2
				600	14	6.9	4.5	3.3	2.6	2.1	1.8	1.4	1.1
TU60E	Rolloed screw	4	Standard	0	73	14	7.8	5.4	4.1	3.3	2.8	2.1	1.7
				200	29	11	6.9	5.0	3.9	3.2	2.7	2.1	1.7
				400	18	9.2	6.1	4.6	3.6	3.0	2.6	2.0	1.6
				600	13	7.7	5.5	4.2	3.4	2.8	2.5	1.9	1.6
	10	Standard	0	43	9.1	5.1	3.5	2.7	2.2	1.8	1.4	1.1	
			200	10	5.6	3.8	2.9	2.3	1.9	1.7	1.3	1.1	
			400	5.8	4.0	3.0	2.4	2.0	1.7	1.5	1.2	1.0	
			600	4.0	3.1	2.5	2.0	1.7	1.5	1.4	1.1	—	

Table 11 Load rating of linear motion rolling guide

Size	Length of slide table	Basic dynamic load rating C N	Basic static load rating Co N	Rated moment ⁽¹⁾ N · m		
				T ₀	T _x	T _y
TU 25	Standard	1770	2840	20.3 (40.6)	10.1 (53.7)	8.4 (45.0)
TU 30	Standard	2280	3810	34.9 (69.8)	16.9 (87.5)	14.2 (73.4)
TU 40	Short	6050	6110	83.8 (167.6)	22.8 (185)	22.8 (185)
	Standard	8410	9780	134 (268)	53.0 (351)	53.0 (351)
TU 50	Long	11200	14700	201 (402)	113 (649)	113 (649)
	Short	8930	8800	156 (312)	39.5 (315)	39.5 (315)
TU 50	Standard	13500	15800	280 (560)	114 (711)	114 (711)
	Long	18400	24600	436 (872)	260 (1420)	260 (1420)
TU 60	Short	12400	12000	236 (472)	62.7 (486)	62.7 (486)
	Standard	18800	21600	425 (850)	181 (1150)	181 (1150)
	Long	26800	35900	708 (1416)	472 (2470)	472 (2470)
TU 86	Short	24100	23800	677 (1354)	183 (1280)	183 (1280)
	Standard	41400	51500	1470 (2940)	764 (4120)	764 (4120)
	Long	49900	67300	1920 (3840)	1270 (6290)	1270 (6290)
TU100	Standard	54600	68500	2230 (4460)	1210 (6460)	1210 (6460)
TU130	Standard	70300	88800	3920 (7840)	1830 (9630)	1830 (9630)
TU50Y	Standard	12000	16400	291 (—)	118 (—)	118 (—)
TU60Y	Standard	16600	22400	441 (—)	187 (—)	187 (—)
TU86Y	Standard	35900	53400	1520 (—)	792 (—)	792 (—)
TU50E	Standard	4300	7000	134 (268)	46.0 (276)	51.0 (306)
TU60E	Standard	7000	11800	260 (520)	101 (606)	120 (720)

Note⁽¹⁾ : Directions are shown in the following figures, the values in the lower row are for two slide tables in close contact.

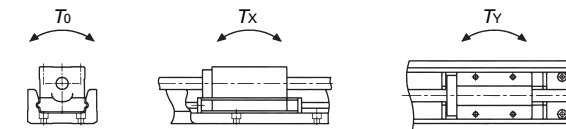

Specification of Ball Screw

In **IKK0** Precision Positioning Table TU, three types of ball screw specifications which are ground screw, rolled screw, and without ball screw can be selected. Table 12 shows load rating, axial clearance and lead of ball screw.

The table without ball screw can be used as a guide track rail in the use of two parallel tables.
Please see Table 13.

Table 12 Specification of ball screw

Size	Type of screw	Lead mm	Shaft dia. mm	Axial clearance mm	Basic dynamic load rating C N	Basic static load rating C ₀ N
TU 25	Ground screw	4	6	0.005 or less	950	1630
TU 30	Ground screw	5	8	0.005 or less	1080	2160
TU 40	Ground screw	4	8	0.005 or less	2290	3575
		8			1450	2155
TU 50	Rolled screw	5	10	0.05 or less	2300	4800
		10			1850	3200
	Ground screw	5	10	0.005 or less	2730	4410
		10			1720	2745
TU 60	Rolled screw	5	12	0.05 or less	2800	5000
		10			1800	3200
	Ground screw ⁽¹⁾	5	12	0.005 or less	3230	6320
		10			2300	3920
TU 86	Rolled screw ⁽²⁾	10	15	0.05 or less	4900	9100
		20			3900	5050
	Ground screw	10	15	0.005 or less	6080	12500
		20			4510	7840
	Ground screw ⁽³⁾	20	20	0.005 or less	6620	12600
	TU100	Ground screw	20	20	0.005 or less	6960
TU130	Ground screw	25	25	0.005 or less	10100	20000
TU50Y	Rolled screw	5	12	0.05 or less	2300	4800
		10			1850	3200
TU60Y	Rolled screw	5	12	0.05 or less	2800	5000
		10			1800	3200
TU86Y	Rolled screw	10	15	0.05 or less	4900	9100
		20			3900	5050
TU50E	Rolled screw	2	8	0.020 or less	1800	3200
TU60E	Rolled screw	4	10	0.020 or less	3000	5300
		10	10		2000	3200

Note⁽¹⁾ : Not applicable for track rail length 990mm and 1190mm.

⁽²⁾ : Not applicable for track rail length 1390mm and 1590mm.

⁽³⁾ : Applicable for track rail length 1390mm and 1590mm.

Table 13 Specifications of the type without ball screw

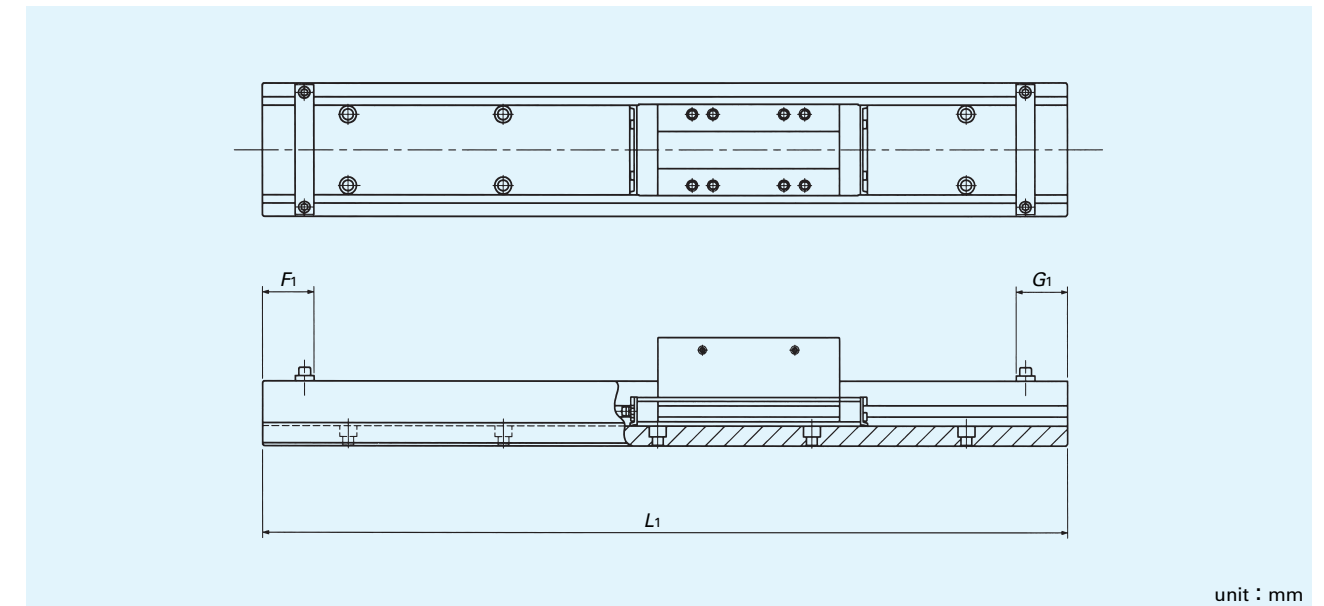

unit : mm

Model	Track rail specification	Track rail length L ₁	Without bridge cover		With bridge cover	
			F ₁	G ₁	F ₁	G ₁
TU 25	For without motor folding back	130, 165, 200	14	14	14	14
TU 30	For without motor folding back	140, 180, 220, 260, 300, 340	14	14	14	14
TU 40	For without motor folding back	180, 240, 300, 360, 420	20	18	20	18
	For with motor folding back	140, 200, 260, 320, 380	20	18	20	18
TU 50	For without motor folding back	220, 300, 380, 460, 540, 620, 700	20	18	20	18
	For with motor folding back	180, 260, 340, 420, 500, 580, 660	20	18	20	18
TU 60	For without motor folding back	290, 390, 490, 590, 690, 790, 990	32	17	35	29
	For with motor folding back	1190	32	17	—	—
TU 86	For without motor folding back	244, 344, 444, 544, 644, 744	32	28	35	29
	For with motor folding back	490, 590, 690, 790, 890, 990, 1090, 1190, 1390	32	19	—	—
TU 100	For without motor folding back	1590	32	19	—	—
	For with motor folding back	442, 542, 642, 742, 842, 942, 1042, 1142	32	28	35	29
TU130	For without motor folding back	1010, 1160, 1310, 1460	35	34	35	34
TU130	For without motor folding back	1010, 1160, 1310, 1460, 1610	35	38	35	38

Remark : For dimensions of the slide table and track rail, see the dimension tables after page B-1.

Rigidity

 Precision Positioning Table TU is designed to achieve high rigidity by adopting extra rigid U-shaped track rail. Moment of inertia of sectional area of the track rail is shown in Table 14. The deformation characteristics of the tables under downward load (actual measurements) are shown in Fig. 2.

Table 14 Moment of inertia of sectional area of track rail



Model	Moment of inertia of sectional area mm ⁴		Center of gravity e mm
	I _x	I _y	
TU 25	3.7×10 ²	7.5×10 ³	2.6
TU 30	9.3×10 ²	1.7×10 ⁴	3.3
TU 40	1.0×10 ⁴	6.8×10 ⁴	6.6
TU 50	2.8×10 ⁴	1.7×10 ⁵	8.7
TU 60	6.4×10 ⁴	3.8×10 ⁵	10.9
TU 86	2.4×10 ⁵	1.6×10 ⁶	14.6
TU100	5.9×10 ⁵	3.3×10 ⁶	18.8
TU130	1.4×10 ⁶	8.8×10 ⁶	23.0
TU50E	1.4×10 ⁴	1.4×10 ⁵	6.7
TU60E	3.9×10 ⁴	3.1×10 ⁵	8.8

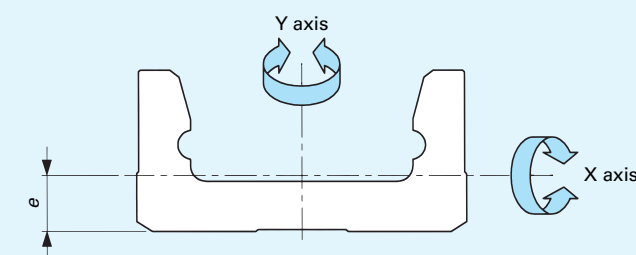
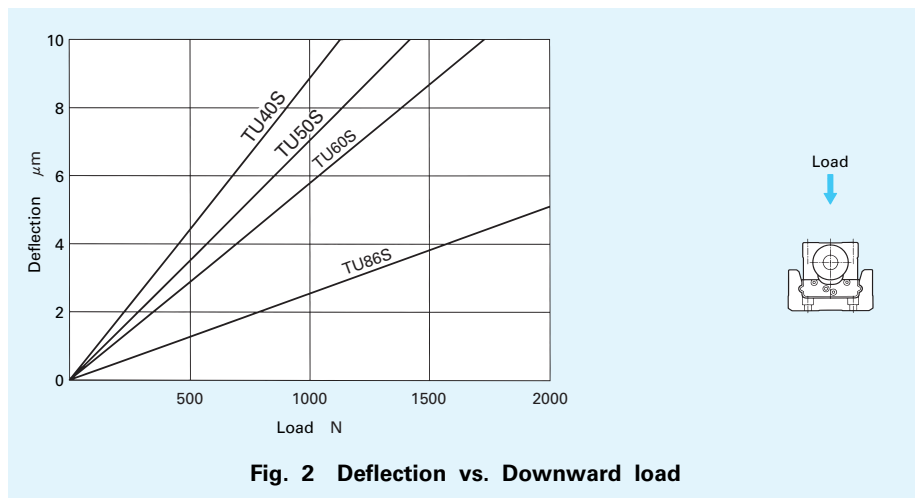

Table inertia and starting torque

The table inertia and starting torque of  Precision Positioning Table TU are shown in Table 15.1, 15.2 and 15.3.

Table 15.1 Table inertia and starting torque of TU

Model	Track rail length mm	Table inertia $J_T^{(2)}$ ×10 ⁻⁶ kg·m ²						Starting torque $T_0^{(2)}$ N·m					
		Standard table						Ground screw					
		Lead 4mm											
TU 25	130	0.018						0.02					
	165	0.021											
	200	0.024											
Model	Track rail length mm	Table inertia $J_T^{(2)}$ ×10 ⁻⁶ kg·m ²						Starting torque $T_0^{(2)}$ N·m					
		Standard table						Ground screw					
		Lead 5mm											
TU 30	140	0.057						0.02					
	180	0.069											
	220	0.082											
	260	0.095											
	300	0.107											
	340	0.120											
Model	Track rail length ⁽¹⁾ mm	Table inertia $J_T^{(2)}$ ×10 ⁻⁶ kg·m ²						Starting torque $T_0^{(2)}$ N·m					
		Short table		Standard table		Long table		Ground screw					
		Lead 4mm	Lead 8mm	Lead 4mm	Lead 8mm	Lead 4mm	Lead 8mm						
TU 40	180 (140)	0.05	0.07	0.06	0.09	—	—	0.06 (0.065)					
	240 (200)	0.07	0.09	0.08	0.11	0.08	0.12						
	300 (260)	0.09	0.11	0.10	0.12	0.10	0.14						
	360 (320)	0.11	0.13	0.12	0.14	0.12	0.16						
	420 (380)	0.13	0.15	0.13	0.16	0.14	0.18						
Model	Track rail length ⁽¹⁾ mm	Table inertia $J_T^{(2)}$ ×10 ⁻⁶ kg·m ²						Starting torque $T_0^{(2)}$ N·m					
		Short table		Standard table		Long table		Rolled screw	Ground screw				
		Lead 5mm	Lead 10mm	Lead 5mm	Lead 10mm	Lead 5mm	Lead 10mm						
TU 50	220 (180)	0.17	0.21	0.18	0.27	—	—	0.08	0.08 (0.085)				
	300 (260)	0.23	0.28	0.24	0.33	0.26	0.40						
	380 (340)	0.29	0.34	0.30	0.39	0.32	0.46						
	460 (420)	0.35	0.40	0.36	0.45	0.38	0.53						
	540 (500)	0.41	0.46	0.43	0.51	0.44	0.59						
	620 (580)	0.47	0.52	0.49	0.57	0.51	0.65						
	700 (660)	0.54	0.58	0.55	0.63	0.57	0.71						
Model	Track rail length ⁽¹⁾ mm	Table inertia $J_T^{(2)}$ ×10 ⁻⁶ kg·m ²									Starting torque $T_0^{(2)}$ N·m		
		Short table			Standard table			Long table			Rolled screw	Ground screw	
		Lead 5mm	Lead 10mm	Lead 20mm	Lead 5mm	Lead 10mm	Lead 20mm	Lead 5mm	Lead 10mm	Lead 20mm		Lead 5mm 10mm	Lead 20mm
TU 60	290 (244)	0.45	0.53	1.03	0.47	0.61	1.43	0.49	0.71	1.94	0.10	0.12 (0.13)	0.16 (0.20)
	390 (344)	0.60	0.69	1.19	0.62	0.77	1.59	0.65	0.87	2.10			
	490 (444)	0.76	0.85	1.34	0.78	0.93	1.75	0.81	1.0	2.26			
	590 (544)	0.92	1.0	1.50	0.94	1.1	1.90	0.97	1.2	2.41			
	690 (644)	1.1	1.2	1.66	1.1	1.2	2.06	1.1	1.3	2.57			
	790 (744)	1.2	1.3	1.82	1.3	1.4	2.22	1.3	1.5	2.73			
	990	1.6	1.7	—	1.6	1.7	—	1.6	1.8	—			
	1190	1.9	2.0	—	1.9	2.1	—	1.9	2.2	—			

Note⁽¹⁾: The values in () are applicable to tables of motor folding back specification.
⁽²⁾: In case of two slide tables, the values are multiplied by 1.5 approx. In case of the motor folding back specification, the values are multiplied 2 approx. The values in () are applicable to the table with C-Lube plate.
⁽³⁾: In case of the table of motor folding back specification, the following values are added to the values in the table.
 TU40 and TU50 : 0.28×10⁻⁶kg·m², TU60 : 1.5×10⁻⁶kg·m²

Table 15.2 Table inertia and starting torque of TU

Model	Track rail length ⁽¹⁾ mm	Table inertia J_r ⁽²⁾ $\times 10^{-5} \text{kg} \cdot \text{m}^2$						Starting torque T_0 ⁽²⁾ N · m	
		Short table		Standard table		Long table		Rolled screw	Ground screw
		Lead 10mm	Lead 20mm	Lead 10mm	Lead 20mm	Lead 10mm	Lead 20mm		
TU 86	490 (442)	2.1	2.9	2.3	3.9	2.4	4.4	0.16	0.16 (0.20)
	590 (542)	2.4	3.2	2.7	4.3	2.8	4.8		
	690 (642)	2.8	3.6	3.1	4.6	3.2	5.1		
	790 (742)	3.2	4.0	3.5	5.0	3.6	5.5		
	890 (842)	3.6	4.4	3.9	5.4	4.0	5.9		
	990 (942)	4.0	4.8	4.2	5.8	4.4	6.3		
	1090 (1042)	4.4	5.2	4.6	6.2	4.8	6.7		
	1190 (1142)	4.8	5.6	5.0	6.6	5.1	7.1		
	1390	—	18	—	19.0	—	19		
1590	—	20	—	21	—	22	—	0.30	
Model	Track rail length mm	Table inertia J_r $\times 10^{-5} \text{kg} \cdot \text{m}^2$						Starting torque T_0 ⁽²⁾ N · m	
		Standard table						Rolled screw	Ground screw
		Lead 20mm							
TU100	1010	15						0.30 (0.36)	
	1160	17							
	1310	19							
	1460	20							
Model	Track rail length mm	Table inertia J_r $\times 10^{-5} \text{kg} \cdot \text{m}^2$						Starting torque T_0 ⁽²⁾ N · m	
		Standard table						Rolled screw	Ground screw
		Lead 25mm							
TU130	1010	39						0.60 (0.70)	
	1160	43							
	1310	48							
	1460	52							
	1610	57							

Note⁽¹⁾ : The values in () are applicable to tables of motor folding back specification.

⁽²⁾ : In case of two slide tables, the values are multiplied by 1.5 approx. In case of the motor folding back specification, the values are multiplied 2 approx. The values in () are applicable to the table with C-Lube plate.

⁽³⁾ : In case of the table of motor folding back specification, the following values are added to the values in the table.

TU86 : $1.5 \times 10^{-5} \text{kg} \cdot \text{m}^2$

Table 15.3 Table inertia and starting torque of TU...Y and TU...E

Model	Track rail length mm	Table inertia J_r $\times 10^{-5} \text{kg} \cdot \text{m}^2$				Starting torque T_0 N · m
		Lead 5mm		Lead 10mm		Rolled screw
TU50Y	240	0.18		0.32		0.08
	320	0.24		0.38		
	400	0.30		0.44		
Model	Track rail length mm	Table inertia J_r $\times 10^{-5} \text{kg} \cdot \text{m}^2$				Starting torque T_0 N · m
		Lead 5mm		Lead 10mm		Rolled screw
TU60Y	400	0.61		0.84		0.10
	500	0.77		1.00		
	600	0.93		1.16		
Model	Track rail length mm	Table inertia J_r $\times 10^{-5} \text{kg} \cdot \text{m}^2$				Starting torque T_0 N · m
		Lead 10mm		Lead 20mm		Rolled screw
TU86Y	400	2.25		5.28		0.16
	600	3.03		6.06		
	800	3.80		6.83		
Model	Track rail length mm	Table inertia J_r $\times 10^{-5} \text{kg} \cdot \text{m}^2$				Starting torque T_0 N · m
		Standard table		Flange type standard table		Rolled screw
		Lead 2mm		Lead 2mm		
TU50E	150	0.057		0.058		0.030 (0.050)
	200	0.073 (0.075)		0.074 (0.076)		
	250	0.089 (0.091)		0.090 (0.092)		
	300	0.105 (0.107)		0.106 (0.108)		
Model	Track rail length mm	Table inertia J_r $\times 10^{-5} \text{kg} \cdot \text{m}^2$				Starting torque T_0 N · m
		Standard table		Flange type standard table		Rolled screw
		Lead 4mm	Lead 10mm	Lead 4mm	Lead 10mm	
TU60E	150	0.162	0.223	0.166	0.249	0.070 (0.105)
	200	0.199	0.261	0.203	0.286	
	300	0.274 (0.286)	0.336 (0.409)	0.278 (0.294)	0.361 (0.460)	
	400	0.349 (0.361)	0.411 (0.484)	0.353 (0.369)	0.436 (0.535)	
	500	0.424 (0.436)	0.486 (0.559)	0.428 (0.444)	0.511 (0.610)	
	600	0.499 (0.511)	0.561 (0.634)	0.503 (0.519)	0.586 (0.685)	
	700	0.587 (0.599)	0.648 (0.722)	0.591 (0.607)	0.674 (0.773)	
	750	—	0.686 (0.759)	—	0.711 (0.810)	

Note : The values in () are applicable with two slide tables.

Cover specification

For Precision Positioning Table TU, a bridge cover and bellows can be prepared for dust protection. Table 16.1 and Table 16.2 show dimensions of the table with bellows.

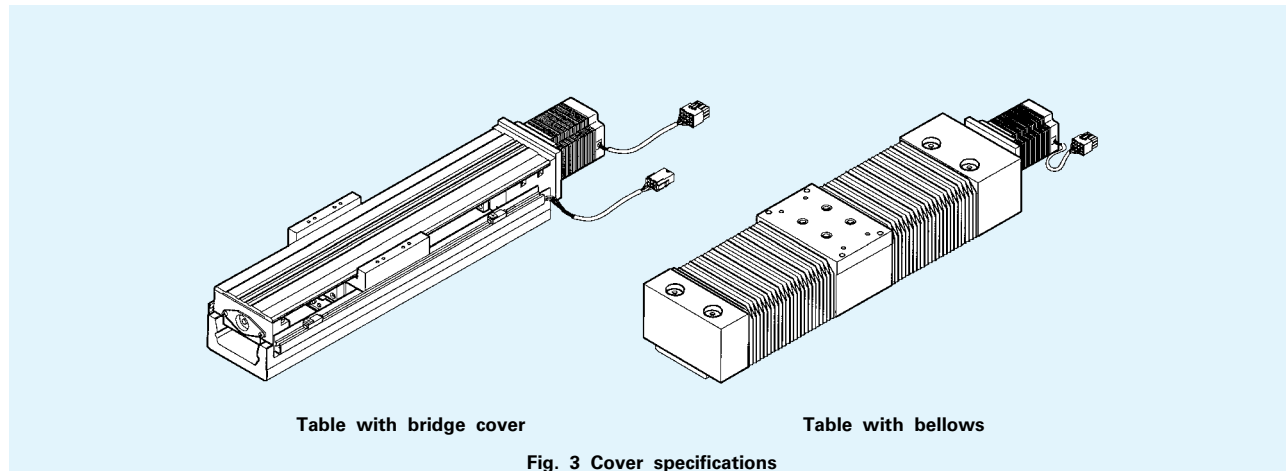
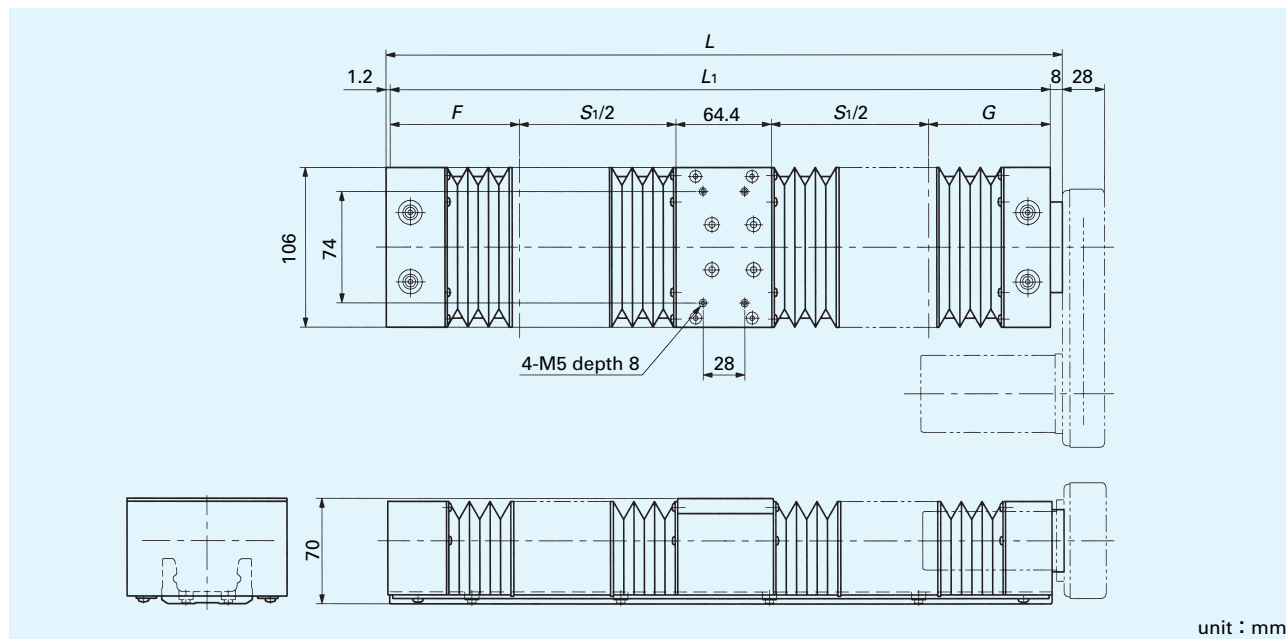

Fig. 3 Cover specifications

Table 16.1 Table with bellows (TU60S)



unit : mm

Track rail length L_1	Total length L	Limit stroke length ⁽¹⁾ S_1	Stroke length ⁽²⁾ S	F	G
290(244)	299.2(253.2)	73.6(68.6)	65(60)	59(59)	93(52)
390(344)	399.2(353.2)	147.6(142.6)	140(135)	72(72)	106(65)
490(444)	499.2(453.2)	219.6(214.6)	210(205)	86(86)	120(79)
590(544)	599.2(553.2)	293.6(288.6)	285(280)	99(99)	133(92)
690(644)	699.2(653.2)	393.6(388.6)	380(375)	99(99)	133(92)
790(744)	799.2(753.2)	465.6(460.6)	455(450)	113(113)	147(106)

Note⁽¹⁾ : Limit stroke length means the limit value of stroke range over which the slide table can travel.

⁽²⁾ : Stroke length means the limit stroke length when limit sensors are attached.

Remarks 1 : The dimensions in () are applicable to the table with bellows of the motor folding back specification.

2 : For the mounting dimensions of the track rail, see the dimension table of TU60.

3 : The dimensions above are also applicable to the table with C-Lube plates.

Table 16.2 Table with bellows (TU86S)

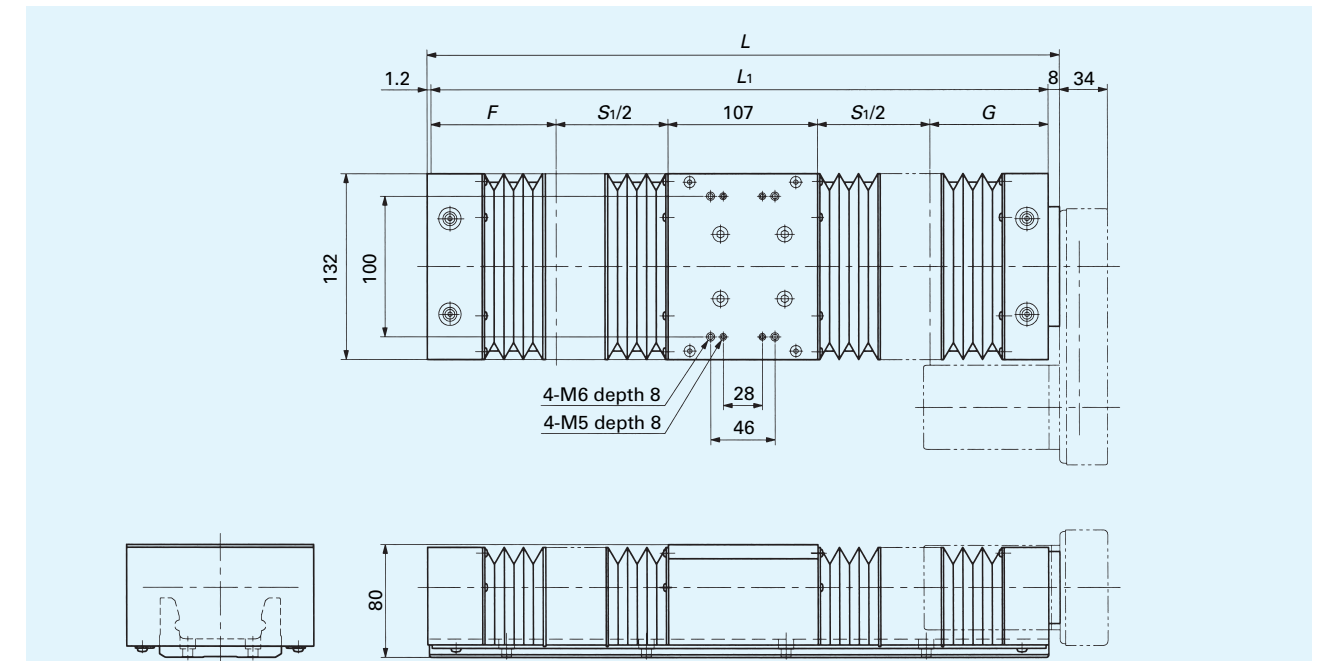

unit : mm

Track rail length L_1	Total length L	Limit stroke length ⁽¹⁾ S_1	Stroke length ⁽²⁾ S	F	G
490(442)	499.2(451.2)	203(198)	195(190)	72(72)	108(65)
590(542)	599.2(551.2)	275(270)	265(260)	86(86)	122(79)
690(642)	699.2(651.2)	349(344)	340(335)	99(99)	135(92)
790(742)	799.2(751.2)	421(416)	410(405)	113(113)	149(106)
890(842)	899.2(851.2)	521(516)	510(505)	113(113)	149(106)
990(942)	999.2(951.2)	593(588)	580(575)	127(127)	163(120)
1090(1042)	1099.2(1051.2)	667(662)	655(650)	140(140)	176(133)
1190(1142)	1199.2(1151.2)	739(734)	730(725)	154(154)	190(147)

Note⁽¹⁾ : Limit stroke length means the limit value of stroke range over which the slide table can travel.

⁽²⁾ : Stroke length means the limit stroke length when limit sensors are attached.

Remarks 1 : The dimensions in () are applicable to the table with bellows of the motor folding back specification.

2 : For the mounting dimensions of the track rail, see the dimension table of TU86.

3 : The dimensions above are also applicable to the table with C-Lube plates.

Sensor specification

The sensor specification for IJK Precision Positioning Table TU indicates the number of sensors and whether or not a sensor rail for fastening the sensor is attached. Table 17 shows the specifications of sensors. Table 18 shows the specifications of sensor connectors. Note that, when two sensors (limit) and three sensors (limit, pre-origin) are specified in the identification number, sensor will not be wired unless specified. The sectional shape of sensor rail is shown in Fig. 4. The timing charts for the case where the number of sensors is set to 4 are shown in Table 19.1, 19.2, 19.3, 19.4, and 19.5. In the tables of motor folding back specification, the CW and CCW movements of the slide table will be opposite to those of the table without motor folding back.

Table 17 Specifications of sensors

Item	Type	Limit, pre-origin	Origin
Type	proximity sensor (NPN type ⁽¹⁾)		
Power supply voltage	DC12~24V ±10%		
Current consumption	10mA or less		
Output	Open collector • Max. current : 100mA • Applied voltage : DC30V or less • Residual voltage : 1.0V or less at 100mA in-flow current 0.4V or less at 16mA in-flow current		
Output operation	When approaching : OFF	When approaching : ON	
Operation indicator	LED (red)		
Circuit diagram			

Note⁽¹⁾ : If PNP type is required, please consult IJK.

Table 18 Specifications of connectors

Pin No.	Signal name	Sensor-side connector type	Opposite-side connector type
1	Origin	Cap housing 172160-1	Plug housing 172168-1
2	Pre-origin		
3	CW limit		
4	CCW limit	Contactor 170365-1	Contactor 170363-1
5	Power input		
6	GND		

Remark : Manufactured by Taiko Electronics AMP Co., Ltd.

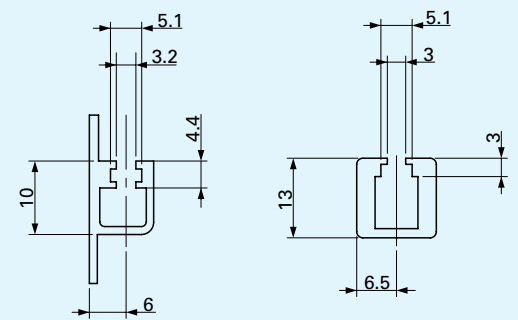
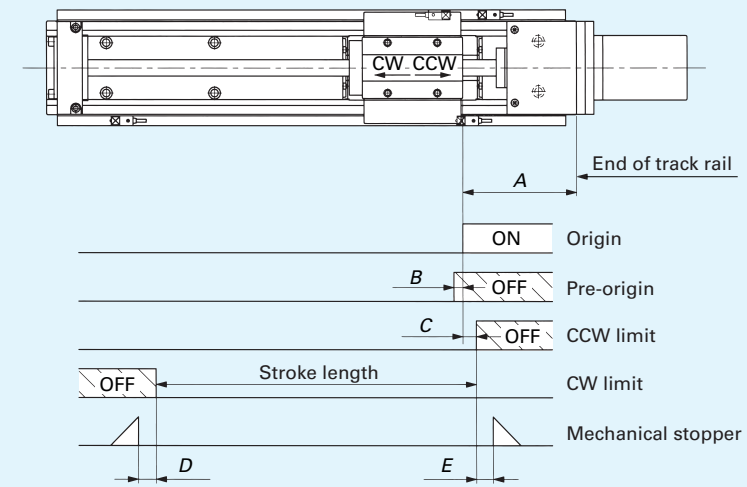

Fig. 4 Sectional shape of sensor rail

Table 19.1 Sensor timing chart of TU (except motor folding back type)



Model	Slide table shape	Ball screw lead	A	B	C	D ⁽¹⁾	E
TU 25	S, F	4	50	2	10	8.4(6)	8
TU 30	S, F	5	50	3	10	10.9(6.4)	8
TU 40	C	4	85	2	10	7.5(5.5)	4.5
		8		6			
	S, F	4	2	10.5(8.5)		8	
TU 50	G	4	85	2	10	4.5(7.5)	8
		8		6			
	S, F	4	2	8.2(7.2)		8	
TU 60	C	5	85	3	10	7.2(6.2)	3.8
		10		7			
	S, F	5	3	8.2(7.2)		8	
TU 86	G	5	85	3	10	4.2(3.2)	8
		10		7			
	YF ⁽⁴⁾	5	88	3		4.2	5
TU 100	C, FC	5	110	3	20	14.6(19.6)	10.4
		10		7			
	S, F	5	100	3		9.6(9.6)	8
TU 130	G, FG	5	100	3	20	9 (8.5)	8
		10		7			
	YF ⁽⁴⁾	5	105	3		4.6	5
TU 86	C, FC	10	105 ⁽²⁾	7	20	13 (14)	11
		20		14			
	S, F	10	105	7		12 (14) ⁽³⁾	4
TU 100	G, FG	10	105	7	20	13 (14)	11
		20		14			
	YF ⁽⁴⁾	10	107	7		12 (14)	11
TU 100	S, F	20	150	14	20	22 (19)	20
	TU 130	S, F					

Note⁽¹⁾ : The dimensions in () are for the case where the number of slide tables is two.

⁽²⁾ : 110mm is applied when the track rail length is 1390mm or 1590mm.

⁽³⁾ : 7(9)mm is applied when the track rail length is 1390mm. (or 1590mm)

⁽⁴⁾ : The values show the case of three sensors.

Remarks 1 : For sensor mounting specification, specify in the identification number.

2 : For the table with bellows, this table is not applicable.

3 : For the code of slide table shape, see page A-7.

4 : For the table with C-Lube plate, see Table 19.3.

Table 19.2 Sensor timing chart (motor folding back specification)

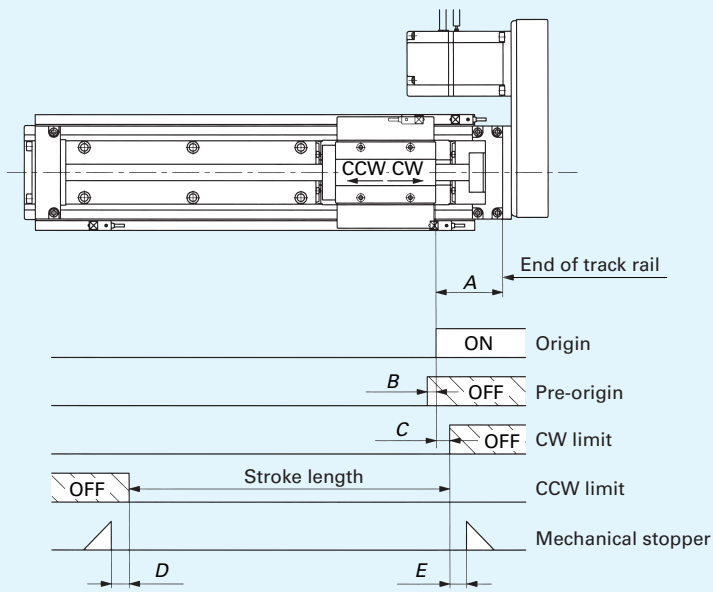

※For the tables of motor folding back specification, the CW and CCW movements of the slide table is opposite to those of the table without motor folding back. unit : mm

Model	Slide table shape	Ball screw lead	A	B	C	D ⁽¹⁾	E
TU 40	C	4	45	2	10	7.5 (5.5)	4.5
		8		6			
	S, F	4	45	2		10.5 (8.5)	8
		8		6			
	G	4	45	2		4.5 (7.5)	8
		8		6			
TU 50	C	5	45	3	10	7.2 (6.2)	3.8
		10		7			
	S, F	5	45	3		8.2 (7.2)	8
		10		7			
	G	5	45	3		4.2 (3.2)	8
		10		7			
TU 60	C, FC	5	64	3	20	14.6(19.6)	10.4
		10		7			
		20		14			
	S, F	5	59	3		9.6 (9.6)	8
		10		7			
		20		14			
G, FG	5	59	3	9 (8.5)	8		
	10		7				
	20		14				
	20		14				
TU 86	C, FC	10	62	7	20	13 (14)	11
		20		14		12 (14)	4
	S, F	10	62	7		13 (14)	11
		20		14			
	G, FG	10	62	7		13 (14)	11
		20		14			

Note⁽¹⁾ : The dimensions in () are for the case where the number of slide tables is two.

Remarks 1 : For sensor mounting specification, specify in the identification number.

2 : For the table with bellows, this table is not applicable.

3 : For the code of slide table shape, see page A-7.

4 : For the table with C-Lube plate, see Table 19.4.

Table 19.3 Sensor timing chart (with C-Lube plate, except motor folding back)

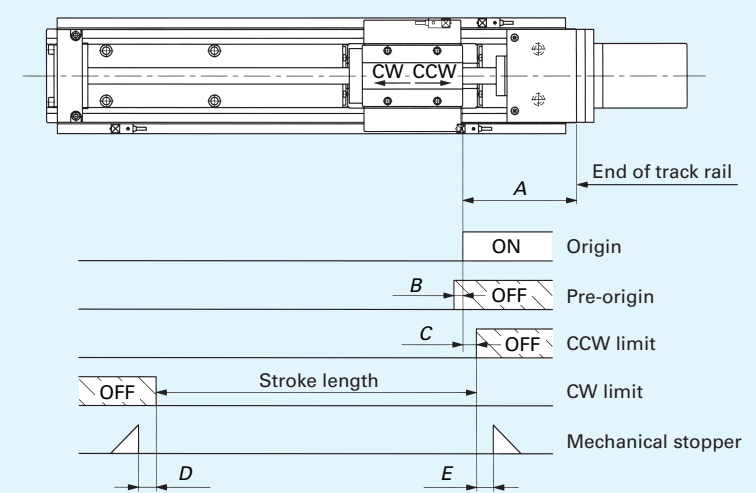

unit : mm

Model	Slide table shape	Ball screw lead	A	B	C	D ⁽¹⁾	E
TU 25	S, F	4	50	2	10	8.4 (6)	8
TU 30	S, F	5	50	3	10	10.9 (6.4)	8
TU 40	C	4	100	2	10	7.5 (5.5)	9
		8		6			
	S, F	4	100	2		5.5 (8.5)	9
		8		6			
	G	4	100	2		9.5 (7.5)	9
		8		6			
TU 50	C	5	100	3	10	7.2 (6.2)	8
		10		7			
	S, F	5	100	3		8.2 (7.2)	8
		10		7			
	G	5	100	3		9.2 (8.2)	8
		10		7			
TU 60	C, FC	5	120	3	20	9.6 (9.6)	5.4
		10		7			
		20		14			
	S, F	5	100	3		4.6 (9.6)	8
		10		7			
		20		14			
G, FG	5	100	3	4 (9)	8		
	10		7				
	20		14				
	20		14				
TU 86	C, FC	10	130	7	20	8 (14)	19
		20		14		7 (14)	9
	S, F	10	105	7		13 (9)	11
		20		14			
	G, FG	10	105	7		8 (9)	11
		20		14			
TU100	S, F	20	150	14	20	17 (14)	20
TU130	S, F	25	160	18	20	18 (18)	20

Note⁽¹⁾ : The dimensions in () are for the case where the number of slide tables is two.

Remarks 1 : For sensor mounting specification, specify in the identification number.

2 : For the table with bellows, this table is not applicable.

3 : For the code of slide table shape, see page A-7.

Table 19.4 Sensor timing chart (motor folding back with C-Lube plate)

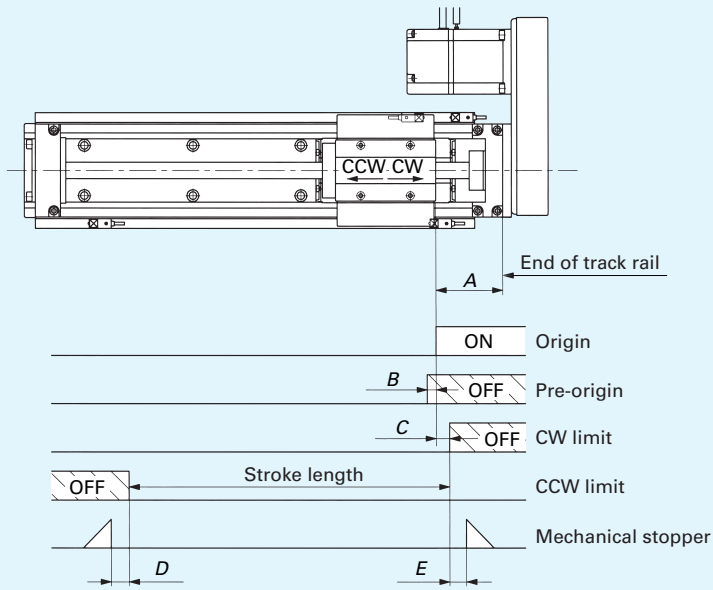

※For the tables of motor folding back specification, the CW and CCW movements of the slide table is opposite to those of the table without motor folding back.

unit : mm

Model	Slide table shape	Ball screw lead	A	B	C	D ⁽¹⁾	E
TU 40	C	4	60	2	10	7.5 (5.5)	9
		8		6			
	S, F	4	60	2			
		8		6			
	G	4	60	2			
		8		6			
TU 50	C	5	60	3	10	7.2 (6.2)	8
		10		7			
	S, F	5	60	3			
		10		7			
	G	5	60	3			
		10		7			
TU 60	C, FC	5	75	3	20	8.6 (8.6)	6.4
		10		7			
		20		14			
	S, F	5	60	3		8.6 (3.6)	9
		10		7			
		20		14			
G, FG	5	60	3	8 (3)	9		
	10		7				
	20		14				
TU 86	C, FC	10	90	7	20	10 (6)	22
		20		14			
		10		7			
	S, F	10	60	7		10 (6)	9
		20		14			
		10		7			
G, FG	10	60	7	5 (6)	9		
	20		14				

Note⁽¹⁾ : The dimensions in () are for the case where the number of slide tables is two.

Remarks 1 : For sensor mounting specification, specify in the identification number.

2 : For the table with bellows, this table is not applicable.

3 : For the code of slide table shape, see page A-7.

Table 19.5 Sensor timing chart (TU...Y, TU...E)

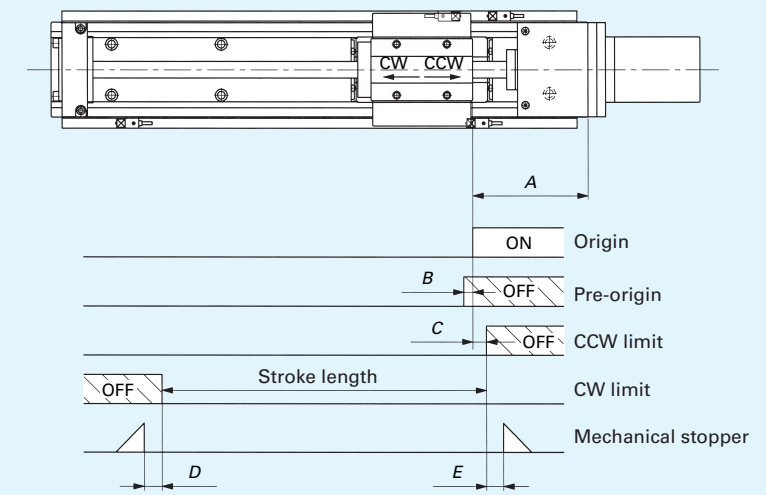

unit : mm

Model	Slide table shape	Ball screw lead	A	B	C	D ⁽¹⁾	E
TU50Y	Standard	5	88	3	10	4.2	5
		10		7			
TU60Y	Standard	5	105	3	20	4.6	5
		10		7			
TU86Y	Standard	10	107	7	20	5	5
TU50E	Standard	2	35	1.5	10	5.7 (7.1)	5.7
TU60E	Standard	4	46	2	20	4.9 (5.5)	5.5
		10		7			

Note⁽¹⁾ : The dimensions in () are for the case where the number of slide tables is two.

Remark : For sensor mounting specification, specify in the identification number.

Motor Folding Back Specification

The motor folding back specification is available for IKO Precision Positioning Table TU. Space can be saved by folding back the motor and reducing the total length of the table. For the motor folding back specification, see the respective dimension tables.

Note that the track rail lengths of motor folding back specification are different from these of tables without motor folding back.

Table without motor folding back unit is the resultant table after removing the motor folding back unit from the motor folding back table. Table 20 shows dimensions of the table without motor folding back unit.

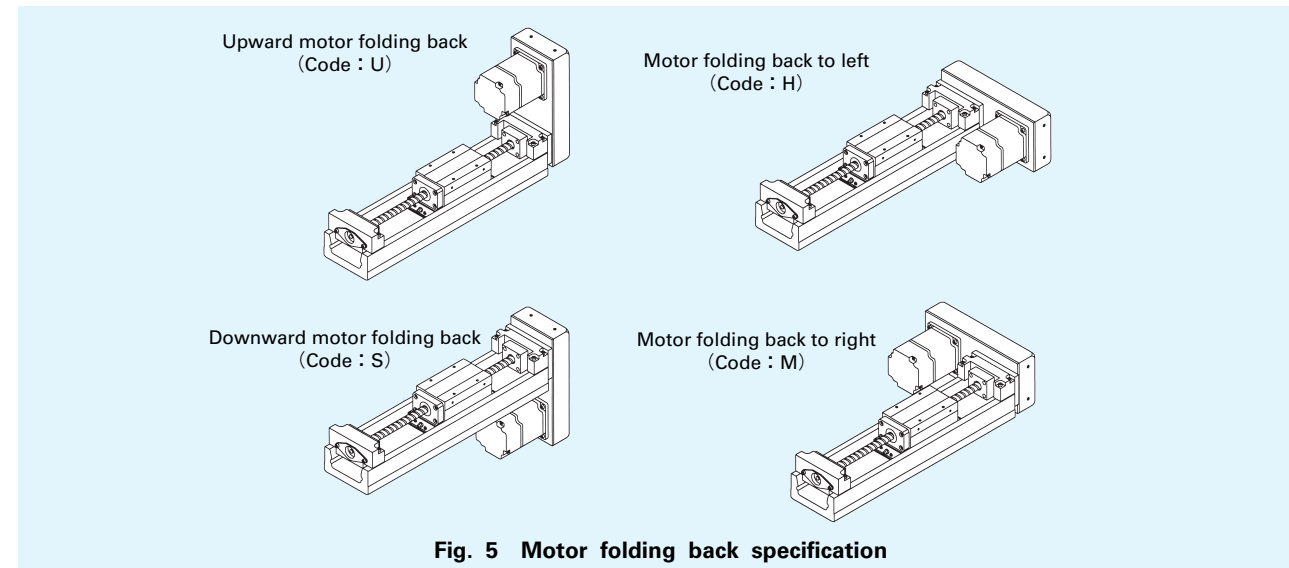

Fig. 5 Motor folding back specification

Table 20 Without motor folding back unit (Code: T, for designing the motor unit at customer.)

Model	A ₂	A ₃	d ₁	H ₁	H ₂	H ₃	W ₁	P ₁	P ₂	M ₁
TU40	18	10	φ 5 ⁰ _{-0.008}	28.5	43.5	30	40	24	24	4-M4 depth 6
TU50	18	10	φ 5 ⁰ _{-0.008}	35	50	30	40	24	24	4-M4 depth 6
TU60	21	15	φ 8 ⁰ _{-0.009}	42	62	40	60	42	20	4-M4 depth 8
TU86	21	15	φ 8 ⁰ _{-0.009}	49.5	69.5	40	85	42	20	4-M4 depth 8

Remark : For the dimensions of the slide table and track rail, see the dimension table of the respective models.

C-Lube Plate Specification

C-Lube plates are assembled inside of the end seals in the slide table and one end of ball screw nut. Lubrication oil impregnated in the C-Lube plate is continuously fed to the raceways, when the slide table and ball screw nut travel along the raceways in uniform contact with the raceways of track rail and ball screw. Re-lubrication interval can be made longer with maintenance and inspection time being reduced.

Table 21.1 and Table 21.2 show dimensions of the table with C-Lube plates.

Table 21.1 Table with C-Lube plates (except motor folding back)

Model	Track rail length L ₁	Total length L	Stroke length ⁽¹⁾ S	E	L ₄	L ₆	L ₇
TU 40C	180	186	30 (-)	90	19.5	60	55
	240	246	90 (40)				
	300	306	150 (100)				
	360	366	210 (160)				
	420	426	270 (220)				
TU 40S TU 40F	240	246	80 (-)	90	31.5	70	67
	300	306	140 (75)				
	360	366	200 (135)				
TU 40G	420	426	260 (195)	90	47.5	85	83
	240	246	60 (-)				
	300	306	120 (-)				
TU 50C	360	366	180 (105)	90	23.8	65	63
	420	426	240 (165)				
	220	226	65 (-)				
	300	306	145 (90)				
	380	386	225 (170)				
TU 50S TU 50F	460	466	305 (250)	90	42.8	85	82
	540	546	385 (330)				
	620	626	465 (410)				
	700	706	545 (490)				
	220	226	45 (-)				
TU 50G	300	306	125 (50)	90	66.8	110	106
	380	386	205 (130)				
	460	466	285 (210)				
	540	546	365 (290)				
	620	626	445 (370)				
TU 50G	700	706	525 (450)	90	66.8	110	106
	300	306	100 (-)				
	380	386	180 (80)				
	460	466	260 (160)				
TU 50G	540	546	340 (240)	90	66.8	110	106
	620	626	420 (320)				
	700	706	500 (400)				

unit : mm

Model	Track rail length L ₁	Total length L	Stroke length ⁽¹⁾ S		E		L ₄	L ₆	L ₇
			Lead 5mm Lead 10mm	Lead 20mm	Lead 5mm Lead 10mm	Lead 20mm			
TU 60C TU 60FC	290	298	90 (40)	70 (-)	100	120	27.4	75	70
	390	398	190 (140)	170 (120)					
	490	498	290 (240)	270 (220)					
	590	598	390 (340)	370 (320)					
	690	698	490 (440)	470 (420)					
TU 60S TU 60F	290	298	90 (-)	70 (-)	80	95	52.4	100	95
	390	398	190 (110)	170 (100)					
	490	498	290 (210)	270 (200)					
	590	598	390 (310)	370 (300)					
	690	698	490 (410)	470 (400)					
TU 60G TU 60FG	290	298	60 (-)	- (-)	80	85	83	130	125
	390	398	160 (50)	155 (-)					
	490	498	260 (150)	255 (150)					
	590	598	360 (250)	355 (250)					
	690	698	460 (350)	455 (350)					
TU 86C TU 86FC	490	498	260 (190)		110	43	95	92	
	590	598	360 (290)						
	690	698	460 (390)						
	790	798	560 (490)						
	890	898	660 (590)						
	990	998	760 (690)						
TU 86S TU 86F	1090	1098	860 (790)		85	93	145	142	
	1190	1198	960 (890)						
	490	498	230 (120)						
	590	598	330 (220)						
	690	698	430 (320)						
	790	798	530 (420)						
TU 86G TU 86FG	890	898	630 (520)		85	118	170	167	
	990	998	730 (620)						
	1090	1098	830 (720)						
	1190	1198	930 (820)						
	490	498	210 (70)						
	590	598	310 (170)						
TU 100S TU 100F	690	698	410 (270)		130	111	170	166	
	790	798	510 (370)						
	890	898	610 (470)						
	990	998	710 (570)						
	1090	1098	810 (670)						
	1190	1198	910 (770)						
TU 130S TU 130F	1010	1020	670 (540)		140	132	195	190	
	1160	1170	820 (690)						
	1310	1320	970 (840)						
	1460	1470	1120 (990)						
TU 130S TU 130F	1010	1020	630 (480)		140	132	195	190	
	1160	1170	780 (630)						
	1310	1320	930 (780)						
	1460	1470	1080 (930)						
	1610	1620	1230 (1080)						

Note⁽¹⁾ : The limit stroke length when limit sensors are attached is indicated. The values in () are for two slide tables in close contact.
Remark : For the dimension of the slide table and track rail, see the respective dimension table.

Table 21.2 Table with C-Lube plates (Motor folding back specification)

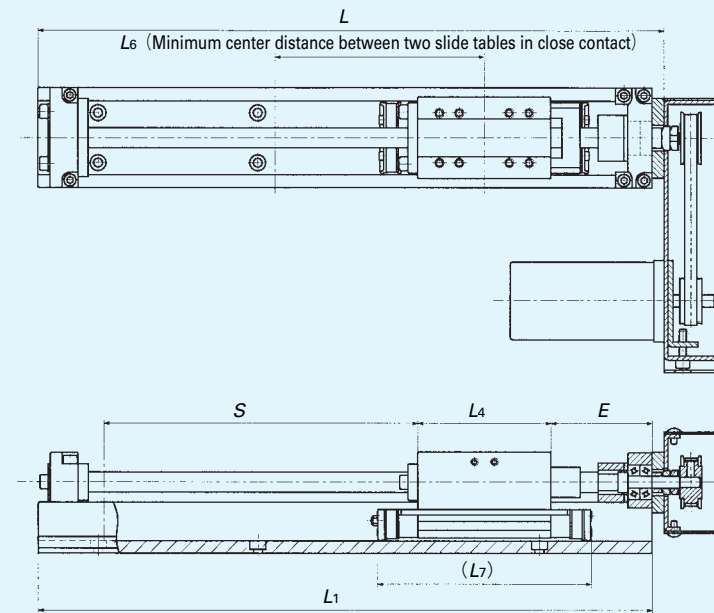

unit : mm

Model	Track rail length L ₁	Total length L	Stroke length ⁽¹⁾ S	E	L ₄	L ₆	L ₇
TU40C	140	146	30 (-)	50	19.5	60	55
	200	206	90 (40)				
	260	266	150 (100)				
	320	326	210 (160)				
TU40S TU40F	380	386	270 (220)	50	31.5	70	67
	200	206	80 (-)				
	260	266	140 (75)				
TU40G	320	326	200 (135)	50	47.5	85	83
	380	386	260 (195)				
	200	206	60 (-)				
TU50C	260	266	120 (-)	50	23.8	65	63
	320	326	180 (105)				
	380	386	240 (165)				
	180	186	65 (-)				
	260	266	145 (90)				
	340	346	225 (170)				
TU50S TU50F	420	426	305 (250)	50	42.8	85	82
	500	506	385 (330)				
	580	586	465 (410)				
	660	666	545 (490)				
	180	186	45 (-)				
	260	266	125 (50)				
TU50G	340	346	205 (130)	50	66.8	110	106
	420	426	285 (210)				
	500	506	365 (290)				
	580	586	445 (370)				
	660	666	525 (450)				
	260	266	100 (-)				
TU50G	340	346	180 (80)	50	66.8	110	106
	420	426	260 (160)				
	500	506	340 (240)				
	580	586	420 (320)				
	660	666	500 (400)				

unit : mm

Model	Track rail length L ₁	Total length L	Stroke length ⁽¹⁾ S		E		L ₄	L ₆	L ₇
			Lead 5mm Lead 10mm	Lead 20mm	Lead 5mm Lead 10mm	Lead 20mm			
TU 60C TU 60FC	244	252	90 (40)	70 (—)	55	74	27.4	75	70
	344	352	190 (140)	170 (120)					
	444	452	290 (240)	270 (220)					
	544	552	390 (340)	370 (320)					
	644	652	490 (440)	470 (420)					
TU 60S TU 60F	244	252	80 (—)	70 (—)	40	49	52.4	100	95
	344	352	180 (110)	170 (100)					
	444	452	280 (210)	270 (200)					
	544	552	380 (310)	370 (300)					
	644	652	480 (410)	470 (400)					
TU 60G TU 60FG	344	352	150 (50)	155 (—)	40	39	83	130	125
	444	452	250 (150)	255 (150)					
	544	552	350 (250)	355 (250)					
	644	652	450 (350)	455 (350)					
	744	752	550 (450)	555 (450)					
Model	Track rail length L ₁	Total length L	Stroke length ⁽¹⁾ S		E		L ₄	L ₆	L ₇
TU 86C TU 86FC	442	450	250 (190)		70	43	95	92	
	542	550	350 (290)						
	642	650	450 (390)						
	742	750	550 (490)						
	842	850	650 (590)						
	942	950	750 (690)						
	1042	1050	850 (790)						
TU 86S TU 86F	442	450	230 (120)		40	93	145	142	
	542	550	330 (220)						
	642	650	430 (320)						
	742	750	530 (420)						
	842	850	630 (520)						
	942	950	730 (620)						
	1042	1050	830 (720)						
TU 86G TU 86FG	442	450	210 (70)		40	118	170	167	
	542	550	310 (170)						
	642	650	410 (270)						
	742	750	510 (370)						
	842	850	610 (470)						
	942	950	710 (570)						
	1042	1050	810 (670)						
1142	1150	910 (770)							

Note⁽¹⁾ : The limit stroke length when limit sensors are attached is indicated. The values in () are for two slide tables in close contact.
 Remark : For the dimension of the slide table and track rail, see the dimension tables after page B-1.

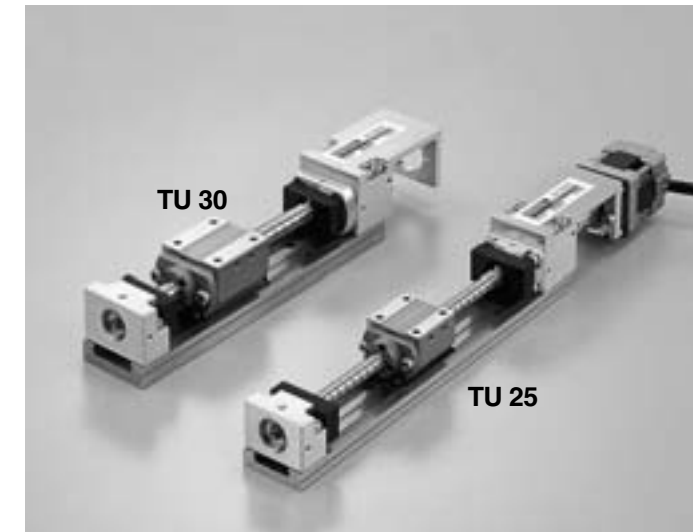

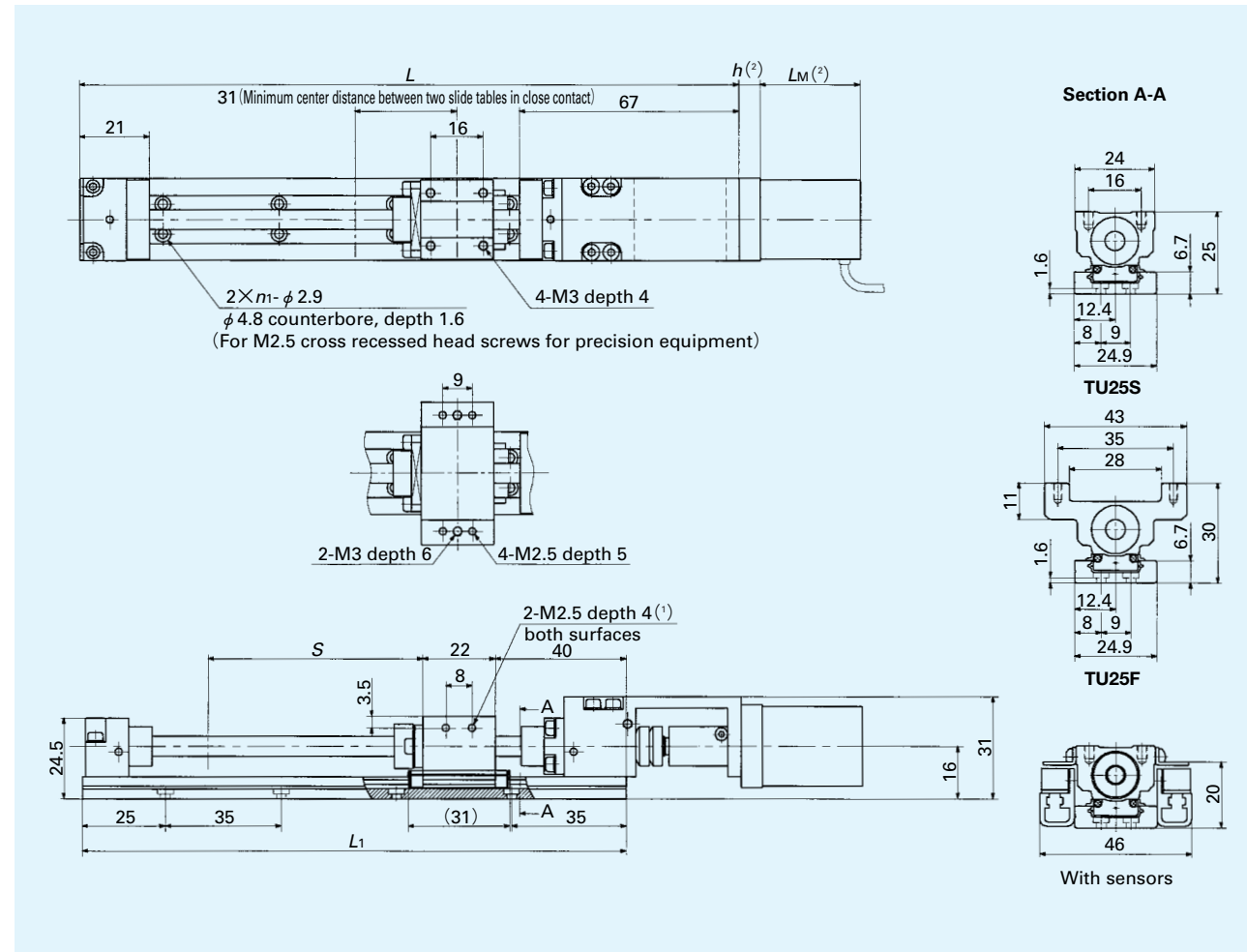

Note⁽¹⁾: These threaded holes are not provided on TU25F.
 Note⁽²⁾: See the dimension table for the motor unit on page C-1.

Dimensions unit : mm

Model number	Track rail length L_1	Total length L	Stroke length $S^{(1)}$	n_1	Mass of slide table kg		Mass ⁽²⁾ kg	
					TU25S	TU25F	TU25S	TU25F
TU25S TU25F	130	165	30 (—)	3	0.05	0.07	0.31	0.33
	165	200	65 (45)	4			0.34	0.36
	200	235	100 (80)	5			0.38	0.40

Note⁽¹⁾: This indicates the stroke length when limit sensors are attached. The values in () are for two slide tables in close contact.
 Note⁽²⁾: The values indicate entire table mass with one slide table. The mass of motor is not included.
 Remark: The track rail and the casing are made of stainless steel.

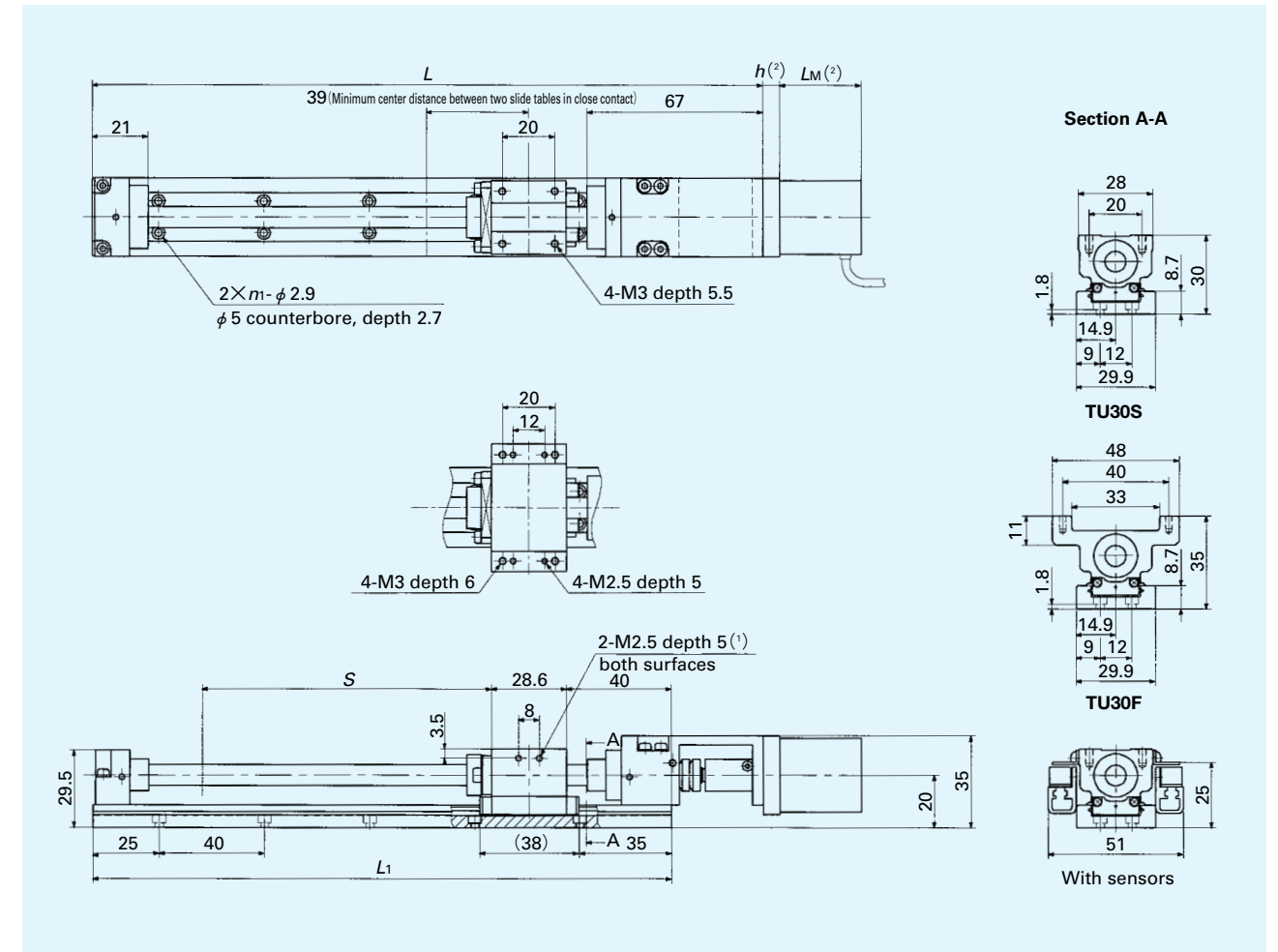

Note⁽¹⁾: These threaded holes are not provided on TU30F.
 Note⁽²⁾: See the dimension table for the motor unit on page C-1.

Dimensions unit : mm

Model number	Track rail length L_1	Total length L	Stroke length $S^{(1)}$	n_1	Mass of slide table kg		Mass ⁽²⁾ kg	
					TU30S	TU30F	TU30S	TU30F
TU30S TU30F	140	175	30 (—)	3	0.09	0.12	0.49	0.52
	180	215	70 (45)	4			0.56	0.59
	220	255	110 (85)	5			0.63	0.66
	260	295	150 (125)	6			0.70	0.73
	300	335	190 (165)	7			0.77	0.80
	340	375	230 (205)	8			0.84	0.87

Note⁽¹⁾: This indicates the stroke length when limit sensors are attached. The values in () are for two slide tables in close contact.
 Note⁽²⁾: The values indicate entire table mass with one slide table. The mass of motor is not included.
 Remark: The track rail and the casing are made of stainless steel.

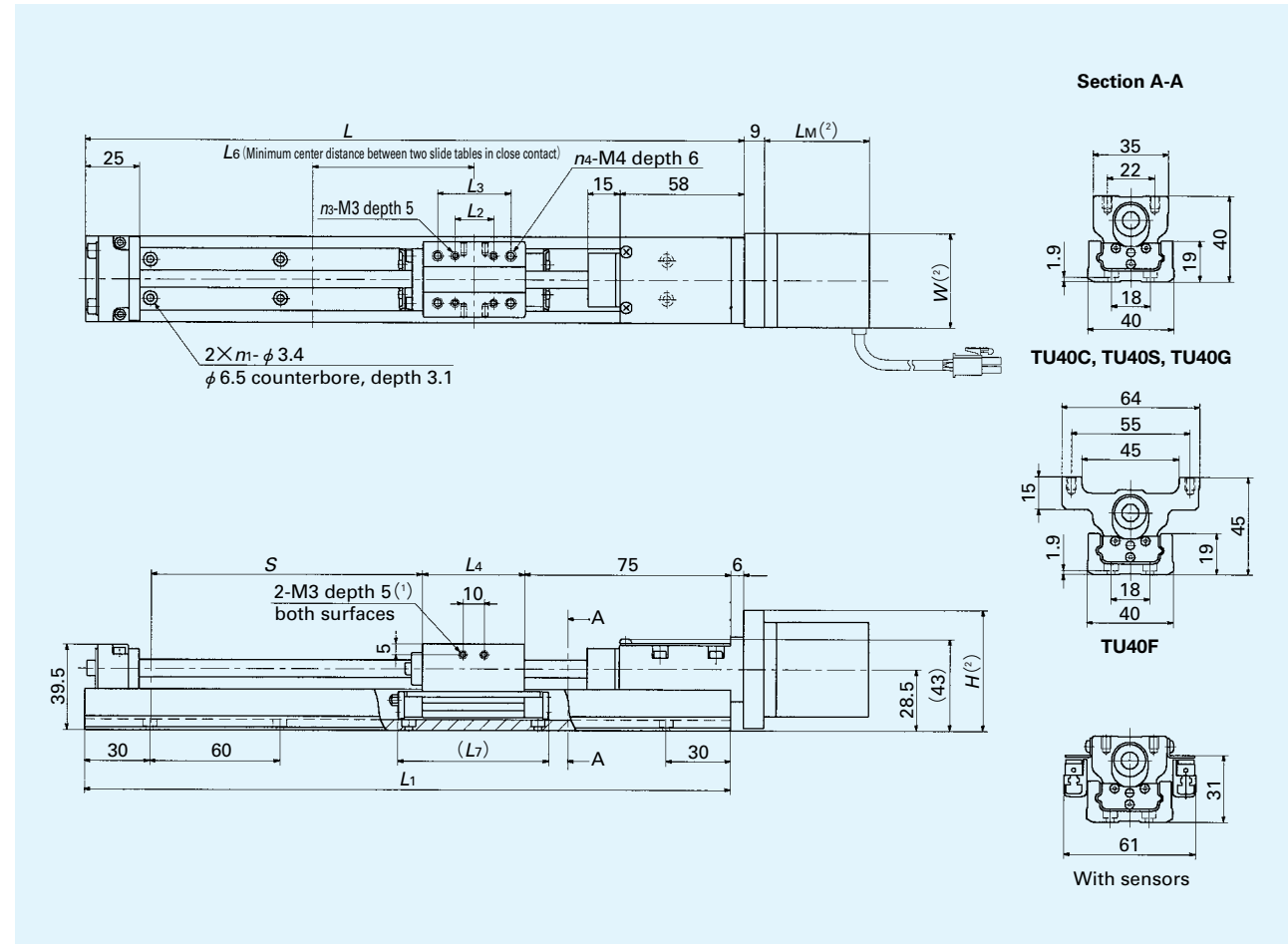

Note⁽¹⁾: These threaded holes are not provided on TU40F.
 (2): See the dimension table for the motor unit on page C-1.

Dimensions of slide table

unit : mm

Model number	L ₂	L ₃	L ₄	L ₆	L ₇	n ₃	n ₄	Mass kg
TU40C	—	—	19.5	45	43	—	2	0.1
TU40S	—	18	31.5	60	55	—	4	0.2
TU40G	18	34	47.5	75	71	4	4	0.3
TU40F	—	18	31.5	60	55	—	4	0.3

Dimensions of track rail

unit : mm

Track rail length L ₁	Total length L	n ₁	Stroke length S ⁽¹⁾			Mass ⁽²⁾ kg			
			TU40C	TU40S TU40F	TU40G	TU40C	TU40S	TU40G	TU40F
180	186	3	45(—)	30(—)	—(—)	0.9	1.0	—	1.1
240	246	4	105(70)	90(40)	80(—)	1.1	1.2	1.3	1.3
300	306	5	165(130)	150(100)	140(70)	1.2	1.3	1.4	1.4
360	366	6	225(190)	210(160)	200(130)	1.4	1.5	1.6	1.6
420	426	7	285(250)	270(220)	260(190)	1.6	1.7	1.8	1.8

Note⁽¹⁾: This indicates the stroke length when limit sensors are attached. The values in () are for two slide tables in close contact.
 (2): The values indicate entire table mass with one slide table. The mass of motor is not included.

Motor folding back specification

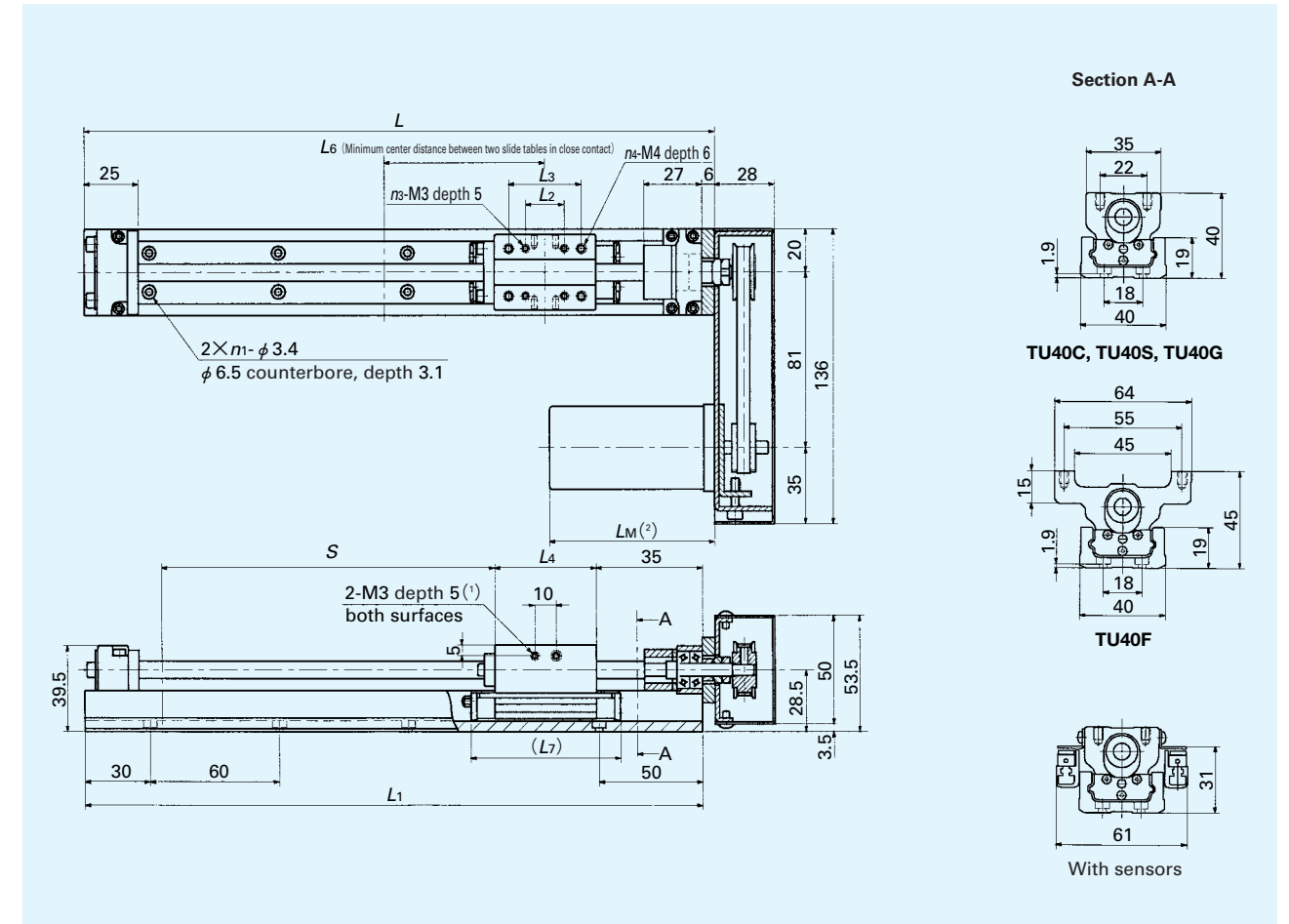

Note⁽¹⁾: These threaded holes are not provided on TU40F.
 (2): See the dimension table for the motor unit on page C-1.

Dimensions of slide table

unit : mm

Model number	L ₂	L ₃	L ₄	L ₆	L ₇	n ₃	n ₄	Mass kg
TU40C	—	—	19.5	45	43	—	2	0.1
TU40S	—	18	31.5	60	55	—	4	0.2
TU40G	18	34	47.5	75	71	4	4	0.3
TU40F	—	18	31.5	60	55	—	4	0.3

Dimensions of track rail

unit : mm

Track rail length L ₁	Total length L	n ₁	Stroke length S ⁽¹⁾			Mass ⁽²⁾ kg			
			TU40C	TU40S TU40F	TU40G	TU40C	TU40S	TU40G	TU40F
140	146	2	45(—)	30(—)	—(—)	1.0	1.1	—	1.2
200	206	3	105(70)	90(40)	80(—)	1.2	1.3	1.4	1.4
260	266	4	165(130)	150(100)	140(70)	1.4	1.5	1.6	1.6
320	326	5	225(190)	210(160)	200(130)	1.6	1.7	1.8	1.8
380	386	6	285(250)	270(220)	260(190)	1.8	1.9	2.0	2.0

Note⁽¹⁾: This indicates the stroke length when limit sensors are attached. The values in () are for two slide tables in close contact.
 (2): The values indicate entire table mass with one slide table. The mass of motor is not included.

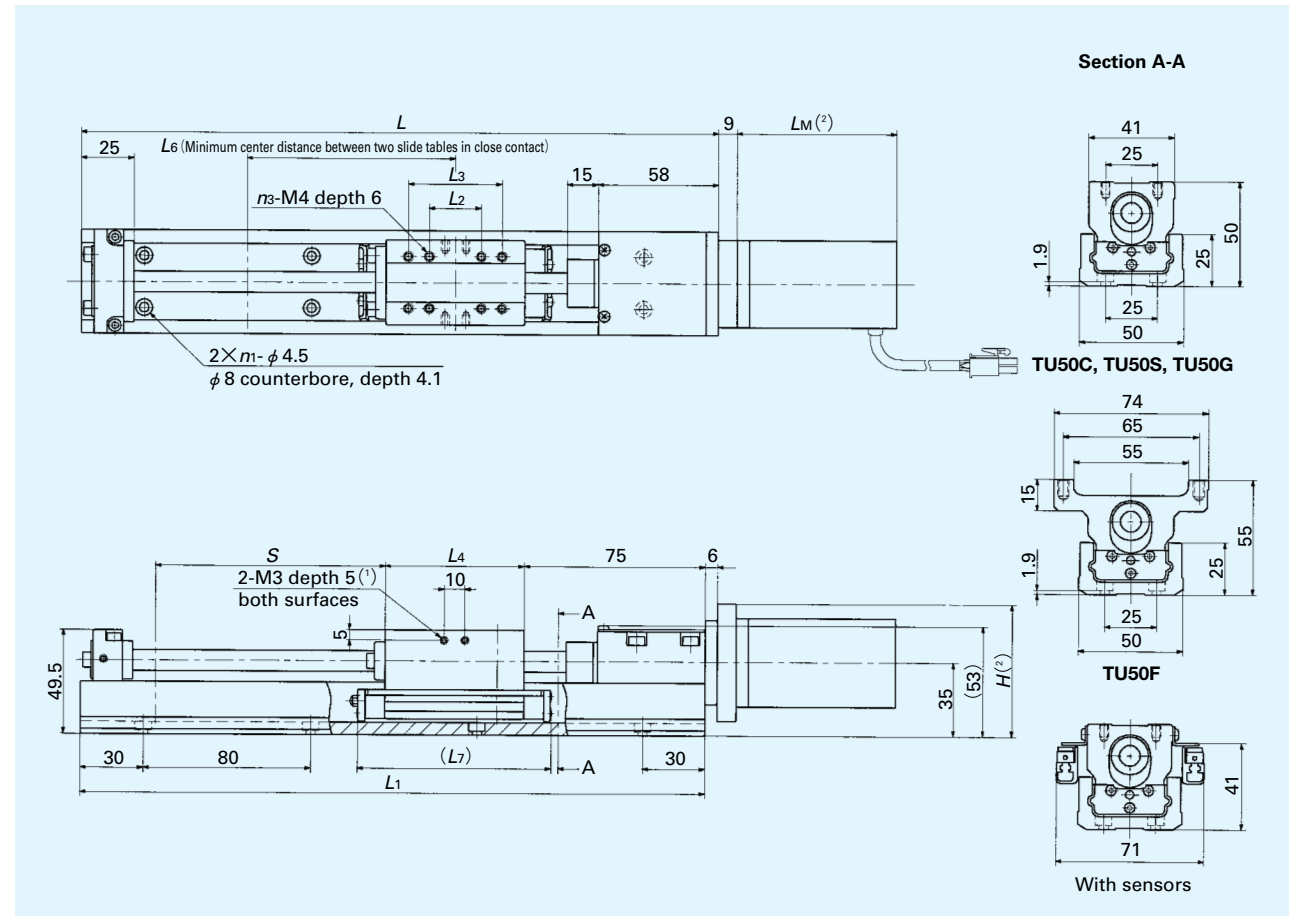

Note⁽¹⁾ : These threaded holes are not provided on TU50F.
 Note⁽²⁾ : See the dimension table for the motor unit on page C-1.

Dimensions of slide table

unit : mm

Model number	L ₂	L ₃	L ₄	L ₆	L ₇	n ₃	Mass kg
TU50C	—	—	23.8	55	51	2	0.2
TU50S	25	—	42.8	75	70	4	0.4
TU50G	25	45	66.8	100	94	8	0.7
TU50F	25	—	42.8	75	70	4	0.5

Dimensions of track rail

unit : mm

Track rail length L ₁	Total length L	n ₁	Stroke length S ⁽¹⁾			Mass ⁽²⁾ kg			
			TU50C	TU50S TU50F	TU50G	TU50C	TU50S	TU50G	TU50F
220	226	3	80(—)	60(—)	—(—)	1.6	1.8	—	1.9
300	306	4	160(115)	140(75)	120(—)	1.9	2.1	2.4	2.2
380	386	5	240(195)	220(155)	200(110)	2.3	2.5	2.8	2.6
460	466	6	320(275)	300(235)	280(190)	2.7	2.9	3.2	3.0
540	546	7	400(355)	380(315)	360(270)	3.1	3.3	3.6	3.4
620	626	8	480(435)	460(395)	440(350)	3.5	3.7	3.9	3.8
700	706	9	560(515)	540(475)	520(430)	3.8	4.0	4.3	4.1

Note⁽¹⁾ : This indicates the stroke length when limit sensors are attached. The values in () are for two slide tables in close contact.
 Note⁽²⁾ : The values indicate entire table mass with one slide table. The mass of motor is not included.

Motor folding back specification

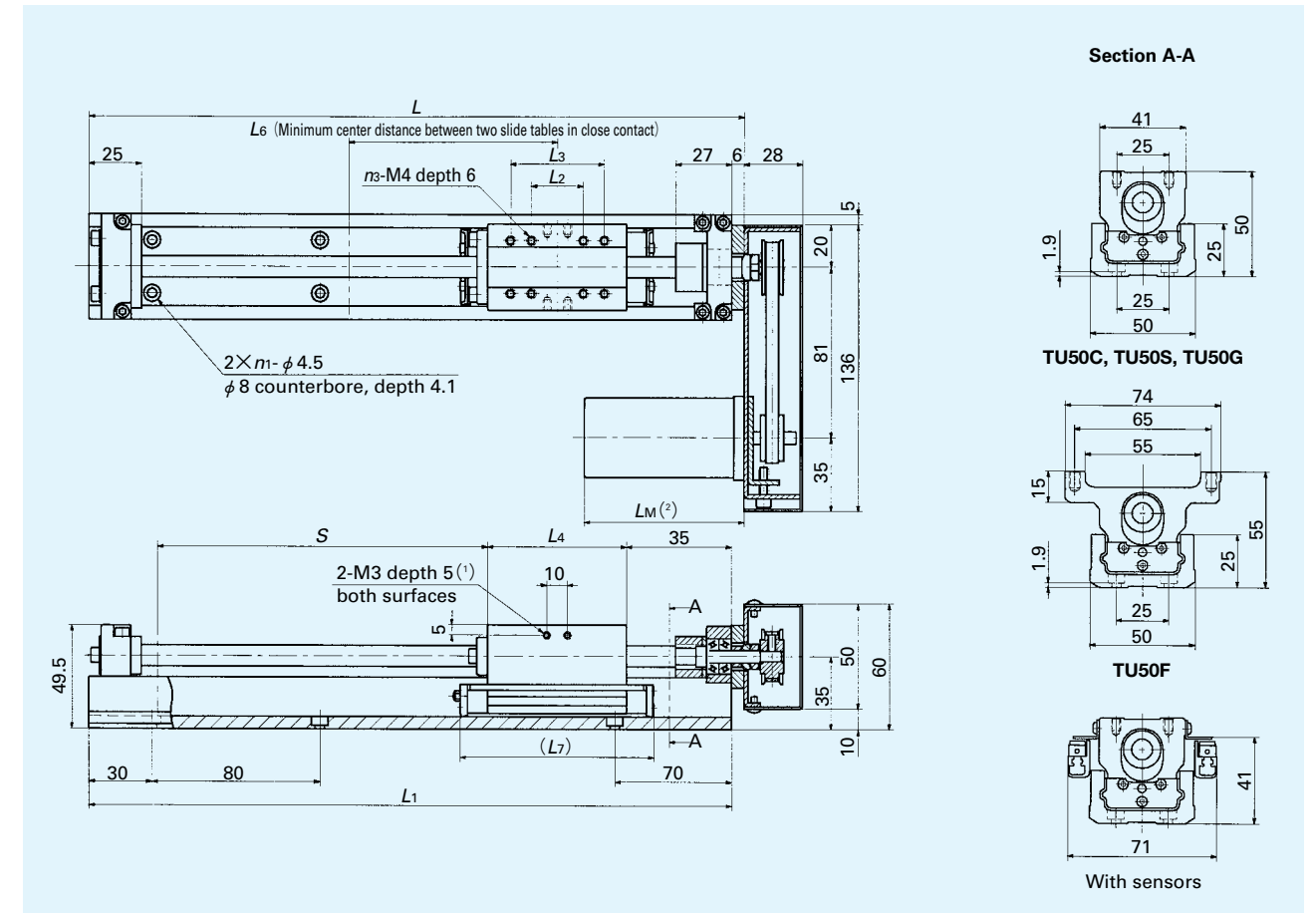

Note⁽¹⁾ : These threaded holes are not provided on TU50F.
 Note⁽²⁾ : See the dimension table for the motor unit on page C-1.

Dimensions of slide table

unit : mm

Model number	L ₂	L ₃	L ₄	L ₆	L ₇	n ₃	Mass kg
TU50C	—	—	23.8	55	51	2	0.2
TU50S	25	—	42.8	75	70	4	0.4
TU50G	25	45	66.8	100	94	8	0.7
TU50F	25	—	42.8	75	70	4	0.5

Dimensions of track rail

unit : mm

Track rail length L ₁	Total length L	n ₁	Stroke length S ⁽¹⁾			Mass ⁽²⁾ kg			
			TU50C	TU50S TU50F	TU50G	TU50C	TU50S	TU50G	TU50F
180	186	2	80(—)	60(—)	—(—)	1.6	1.8	—	1.9
260	266	3	160(115)	140(75)	120(—)	1.9	2.1	2.4	2.2
340	346	4	240(195)	220(155)	200(110)	2.3	2.5	2.8	2.6
420	426	5	320(275)	300(235)	280(190)	2.7	2.9	3.2	3.0
500	506	6	400(355)	380(315)	360(270)	3.1	3.3	3.6	3.4
580	586	7	480(435)	460(395)	440(350)	3.5	3.7	3.9	3.8
660	666	8	560(515)	540(475)	520(430)	3.8	4.0	4.3	4.1

Note⁽¹⁾ : This indicates the stroke length when limit sensors are attached. The values in () are for two slide tables in close contact.
 Note⁽²⁾ : The values indicate entire table mass with one slide table. The mass of motor is not included.

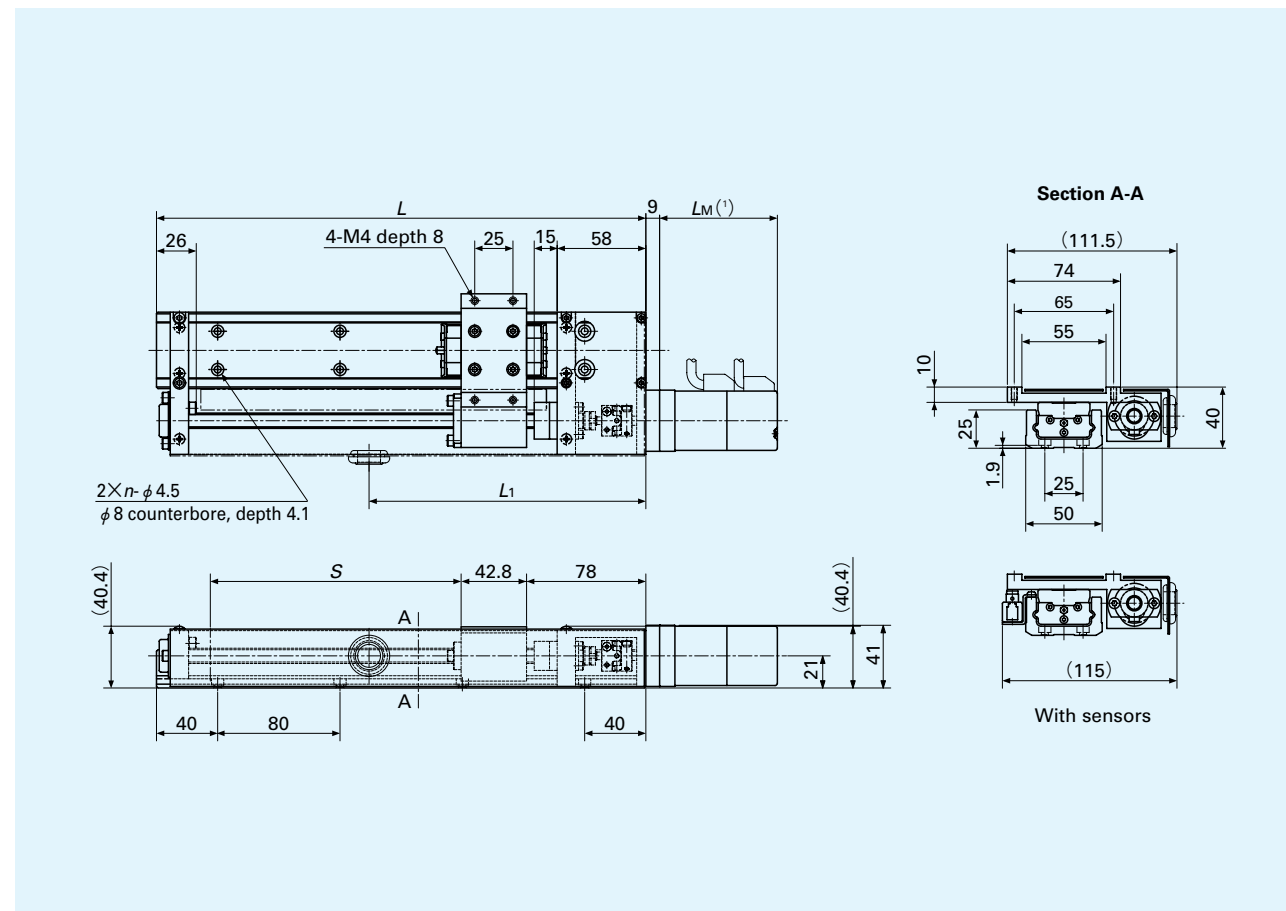

Note⁽¹⁾: See the dimension table for the motor unit on page C-3.

Dimensions unit : mm

Track rail length L	L_1	n	Stroke length $S^{(1)}$	Mass of slide table kg	Mass ⁽²⁾ kg
240	141	3	84	0.7	2.3
320	181	4	164		2.8
400	221	5	244		3.3

Note⁽¹⁾: This indicates the stroke length when limit sensors are attached.

⁽²⁾: The mass of motor is not included.

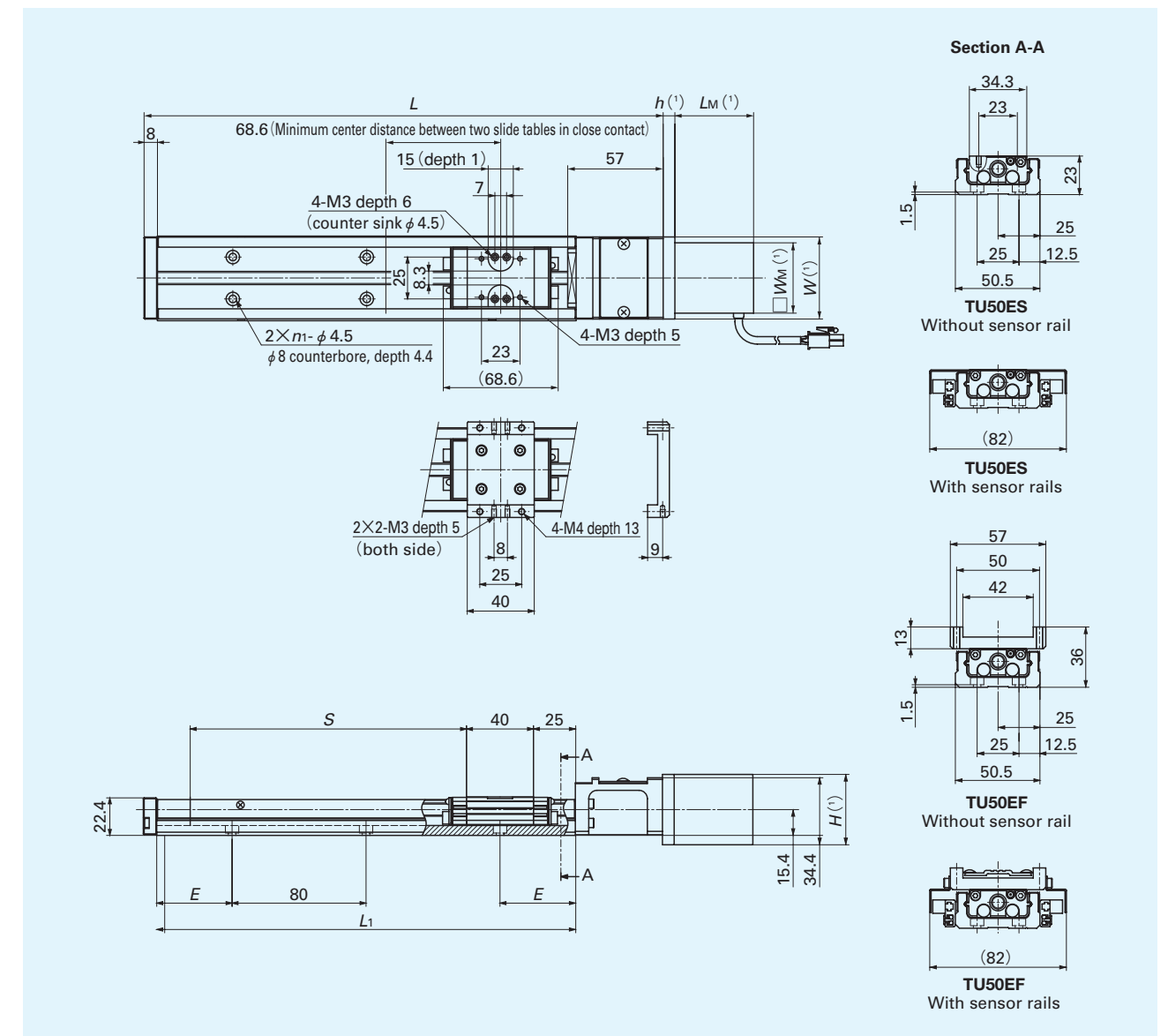

Note⁽¹⁾: See the dimension table for the motor unit on page C-4.

Dimensions unit : mm

Model number	Track rail length L_1	Total length L	Stroke length $S^{(1)}$	m_1	E	Mass of slide table kg	Mass ⁽²⁾ kg
TU50ES	150	210	65 (-)	2	35	0.14	0.98
	200	260	115 (45)	3	20		1.19
	250	310	165 (95)	3	45		1.38
	300	360	215 (145)	4	30		1.58
TU50EF	150	210	65 (-)	2	35	0.19	1.06
	200	260	115 (45)	3	20		1.26
	250	310	165 (95)	3	45		1.45
	300	360	215 (145)	4	30		1.64

Note⁽¹⁾: This indicates the stroke length when limit sensors are attached. The values in () are for two slide tables in close contact.

⁽²⁾: The values indicate entire table mass with one slide table. The mass of motor is not included.

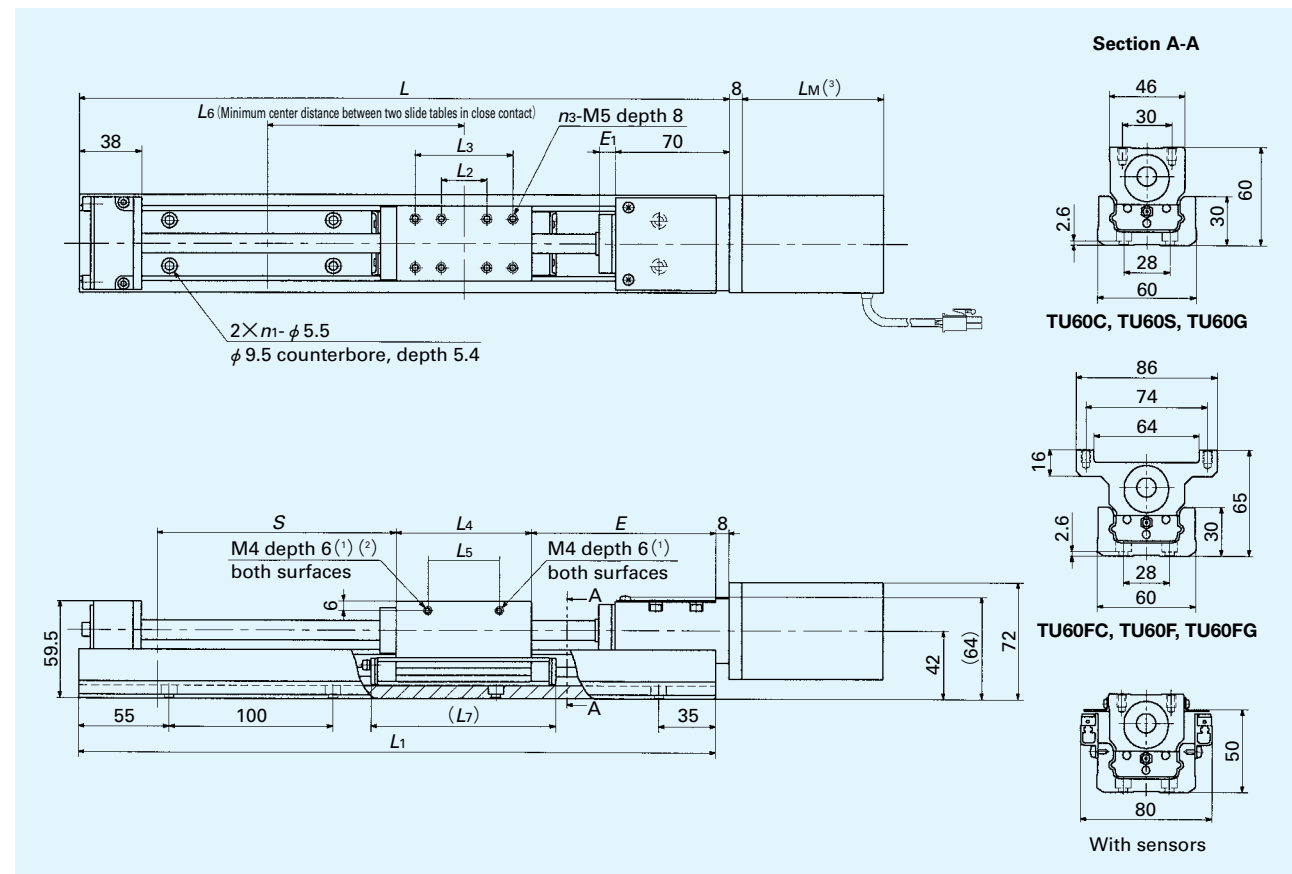

Note⁽¹⁾: These threaded holes are not provided on TU60FC, TU60F and TU60FG.

⁽²⁾: $\phi 3$ depth 2 in the case of TU60C

⁽³⁾: See the dimension table for the motor unit on page C-1.

Dimensions of slide table

unit : mm

Model number	L ₂	L ₃	L ₄	L ₅	L ₆	L ₇	n ₃	E	E ₁	Mass kg
TU60C	—	—	27.4	17.4	65	58	2	90	15	0.3
TU60S	28	—	52.4	18	90	83	4	80	10	0.6
TU60G	28	60	83	44	120.5	113	8	80	10	1.0
TU60FC	—	—	27.4	—	65	58	2	90	15	0.4
TU60F	28	—	52.4	—	90	83	4	80	10	0.8
TU60FG	28	60	83	—	120.5	113	8	80	10	1.3

Dimensions of track rail

unit : mm

Track rail length L ₁	Total length L	n ₁	Stroke length S ⁽¹⁾			Mass ⁽²⁾ kg					
			TU60C TU60FC	TU60S TU60F	TU60G TU60FG	TU60C	TU60S	TU60G	TU60FC	TU60F	TU60FG
290	298	3	110 (50)	100 (—)	70 (—)	3.0	3.3	3.6	3.1	3.5	3.9
390	398	4	210 (150)	200 (120)	170 (60)	3.7	4.0	4.4	3.8	4.2	4.7
490	498	5	310 (250)	300 (220)	270 (160)	4.5	4.8	5.1	4.6	4.9	5.4
590	598	6	410 (350)	400 (320)	370 (260)	5.2	5.5	5.8	5.3	5.7	6.1
690	698	7	510 (450)	500 (420)	470 (360)	6.0	6.2	6.6	6.1	6.4	6.9
790	798	8	610 (550)	600 (520)	570 (460)	6.7	7.0	7.3	6.8	7.2	7.6
990	998	10	810 (750)	800 (720)	770 (660)	8.3	8.6	9.0	8.4	8.7	9.1
1190	1198	12	1010 (950)	1000 (920)	970 (860)	9.8	10.1	10.5	9.9	10.2	10.6

Note⁽¹⁾: This indicates the stroke length when limit sensors are attached. The values in () are for two slide tables in close contact.

⁽²⁾: The values indicate entire table mass with one slide table. The mass of motor is not included.

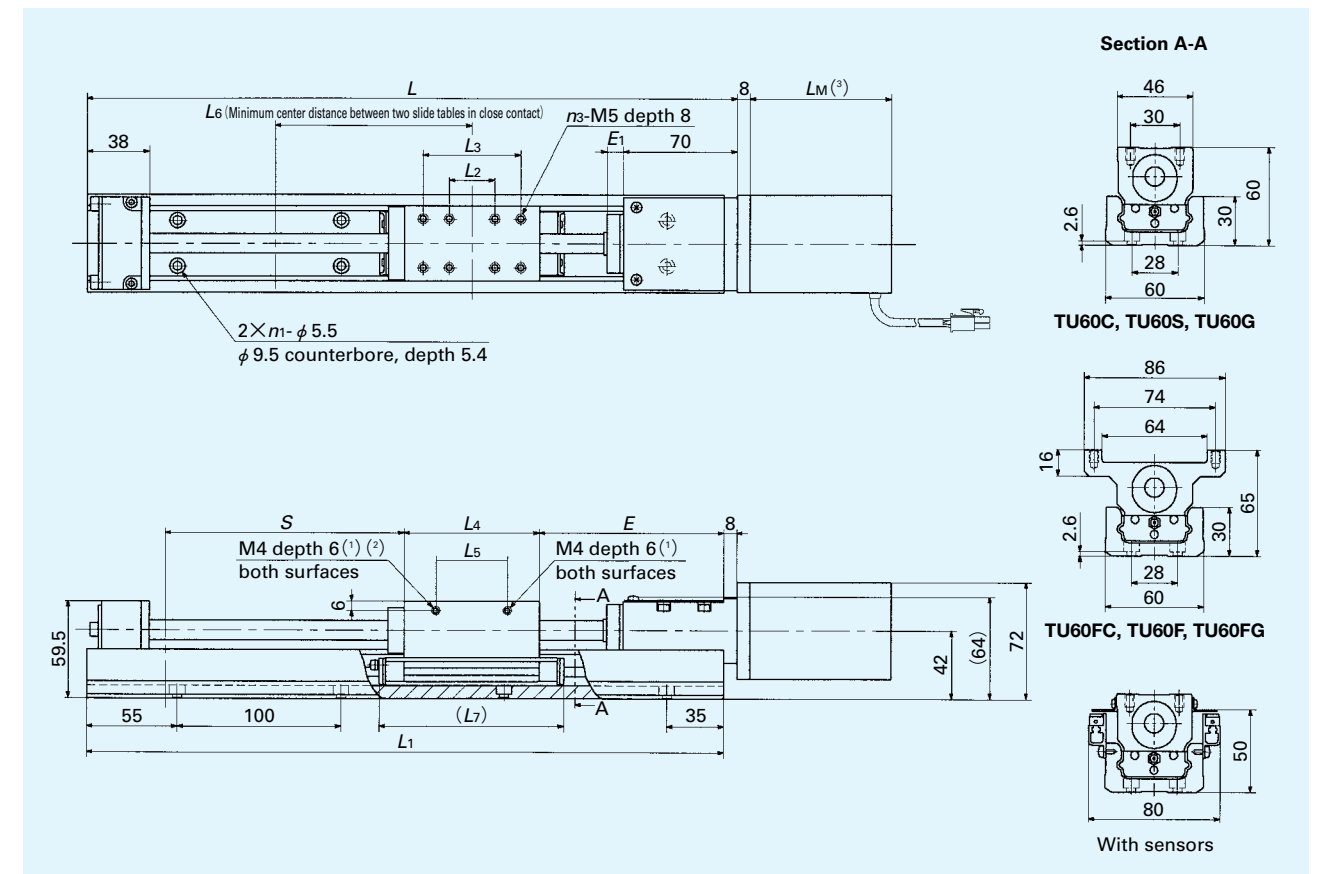

Note⁽¹⁾: These threaded holes are not provided on TU60FC, TU60F and TU60FG.

⁽²⁾: $\phi 3$ depth 2 in the case of TU60C

⁽³⁾: See the dimension table for the motor unit on page C-1.

Dimensions of slide table

unit : mm

Model number	L ₂	L ₃	L ₄	L ₅	L ₆	L ₇	n ₃	E	E ₁	Mass kg
TU60C	—	—	27.4	17.4	65	58	2	110	15	0.3
TU60S	28	—	52.4	18	90	83	4	85	15	0.6
TU60G	28	60	83	44	120.5	113	8	85	15	1.0
TU60FC	—	—	27.4	—	65	58	2	110	15	0.4
TU60F	28	—	52.4	—	90	83	4	85	15	0.8
TU60FG	28	60	83	—	120.5	113	8	85	15	1.3

Dimensions of track rail

unit : mm

Track rail length L ₁	Total length L	n ₁	Stroke length S ⁽¹⁾			Mass ⁽²⁾ kg					
			TU60C TU60FC	TU60S TU60F	TU60G TU60FG	TU60C	TU60S	TU60G	TU60FC	TU60F	TU60FG
290	298	3	95 (—)	95 (—)	65 (—)	3.1	3.4	3.7	3.2	3.6	4.0
390	398	4	195 (135)	195 (115)	165 (—)	3.8	4.1	4.5	3.9	4.3	4.8
490	498	5	295 (235)	295 (215)	265 (155)	4.6	4.9	5.2	4.7	5.0	5.5
590	598	6	395 (335)	395 (315)	365 (255)	5.3	5.6	5.9	5.4	5.8	6.2
690	698	7	495 (435)	495 (415)	465 (355)	6.1	6.3	6.7	6.2	6.5	7.0
790	798	8	595 (535)	595 (515)	565 (455)	6.8	7.1	7.4	6.9	7.3	7.7

Note⁽¹⁾: This indicates the stroke length when limit sensors are attached. The values in () are for two slide tables in close contact.

⁽²⁾: The values indicate entire table mass with one slide table. The mass of motor is not included.

Motor folding back specification

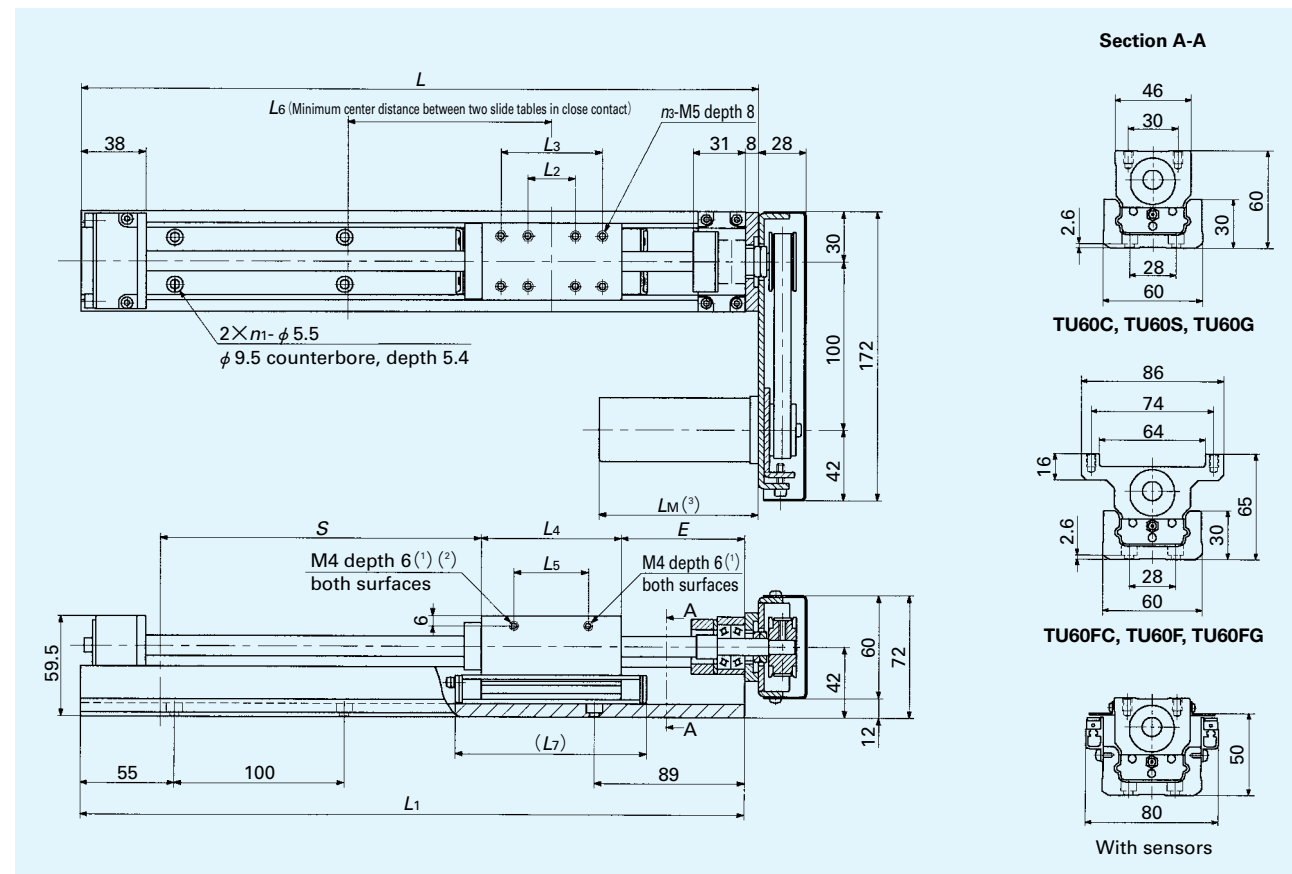

Note⁽¹⁾: These threaded holes are not provided on TU60FC, TU60F and TU60FG.

⁽²⁾: φ3 depth 2 in the case of TU60C

⁽³⁾: See the dimension table for the motor unit on page C-1.

Dimensions of slide table

unit : mm

Model number	L ₂	L ₃	L ₄	L ₅	L ₆	L ₇	n ₃	E	Mass kg
TU60C	—	—	27.4	17.4	65	58	2	44	0.3
TU60S	28	—	52.4	18	90	83	4	39	0.6
TU60G	28	60	83	44	120.5	113	8	39	1.0
TU60FC	—	—	27.4	—	65	58	2	44	0.4
TU60F	28	—	52.4	—	90	83	4	39	0.8
TU60FG	28	60	83	—	120.5	113	8	39	1.3

Dimensions of track rail

unit : mm

Track rail length L ₁	Total length L	n ₁	Stroke length S ⁽¹⁾			Mass ⁽²⁾ kg					
			TU60C TU60FC	TU60S TU60F	TU60G TU60FG	TU60C	TU60S	TU60G	TU60FC	TU60F	TU60FG
244	252	2	110(50)	95(—)	—	3.6	3.9	—	3.7	4.1	—
344	352	3	210(150)	195(115)	165(55)	4.3	4.6	5.0	4.4	4.8	5.3
444	452	4	310(250)	295(215)	265(155)	5.1	5.4	5.7	5.2	5.5	6.0
544	552	5	410(350)	395(315)	365(255)	5.8	6.1	6.4	5.9	6.3	6.7
644	652	6	510(450)	495(415)	465(355)	6.6	6.8	7.2	6.7	7.0	7.5
744	752	7	610(550)	595(515)	565(455)	7.5	7.6	7.9	7.6	7.8	8.2

Note⁽¹⁾: This indicates the stroke length when limit sensors are attached. The values in () are for two slide tables in close contact.

⁽²⁾: The values indicate entire table mass with one slide table. The mass of motor is not included.

Motor folding back specification

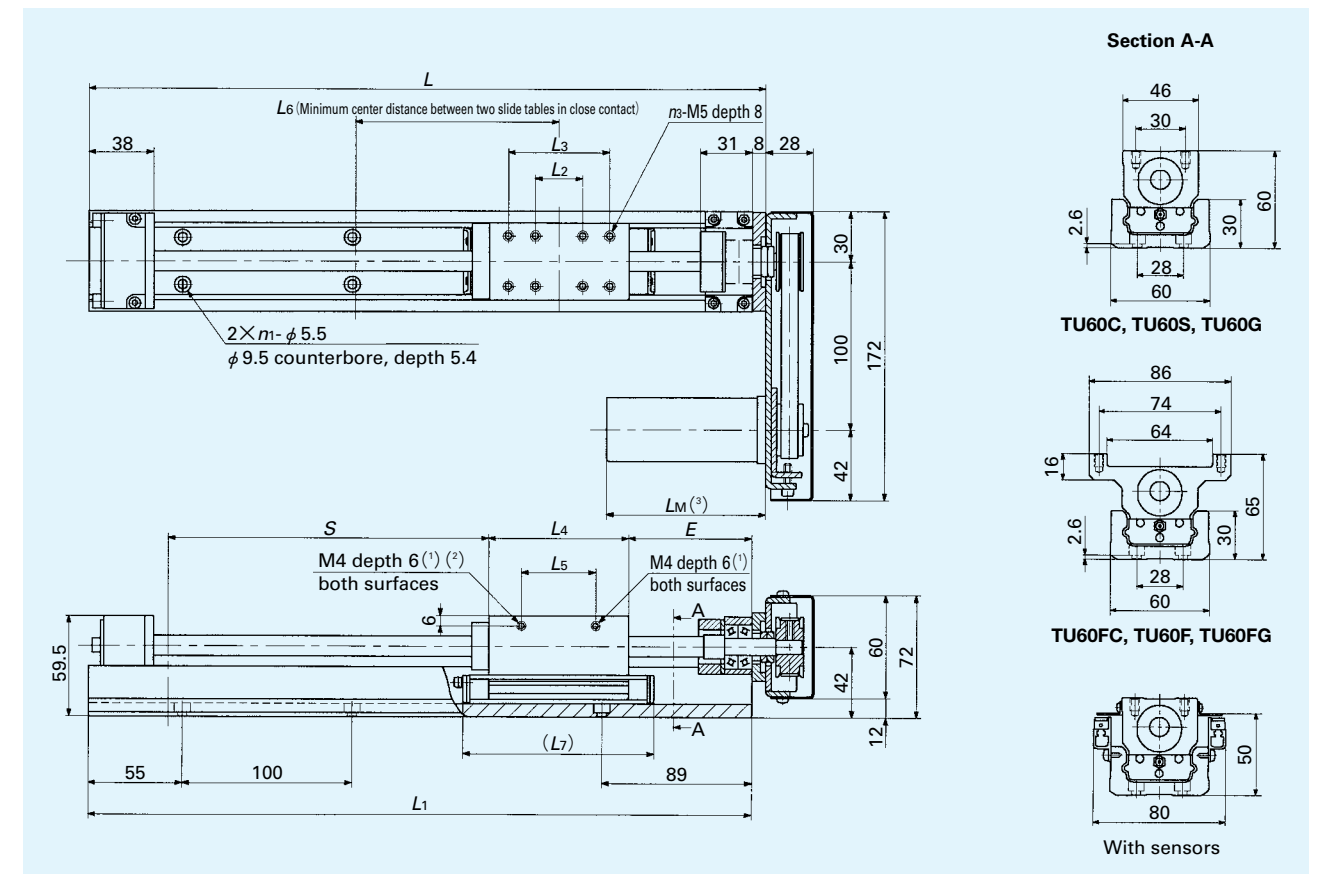

Note⁽¹⁾: These threaded holes are not provided on TU60FC, TU60F and TU60FG.

⁽²⁾: φ3 depth 2 in the case of TU60C

⁽³⁾: See the dimension table for the motor unit on page C-1.

Dimensions of slide table

unit : mm

Model number	L ₂	L ₃	L ₄	L ₅	L ₆	L ₇	n ₃	E	Mass kg
TU60C	—	—	27.4	17.4	65	58	2	64	0.3
TU60S	28	—	52.4	18	90	83	4	39	0.6
TU60G	28	60	83	44	120.5	113	8	39	1.0
TU60FC	—	—	27.4	—	65	58	2	64	0.4
TU60F	28	—	52.4	—	90	83	4	39	0.8
TU60FG	28	60	83	—	120.5	113	8	39	1.3

Dimensions of track rail

unit : mm

Track rail length L ₁	Total length L	n ₁	Stroke length S ⁽¹⁾			Mass ⁽²⁾ kg					
			TU60C TU60FC	TU60S TU60F	TU60G TU60FG	TU60C	TU60S	TU60G	TU60FC	TU60F	TU60FG
244	252	2	95(—)	95(—)	—	3.7	4.0	—	3.8	4.2	—
344	352	3	195(135)	195(115)	165(—)	4.4	4.7	5.1	4.5	4.9	5.4
444	452	4	295(235)	295(215)	265(155)	5.2	5.5	5.8	5.3	5.6	6.1
544	552	5	395(335)	395(315)	365(255)	5.9	6.2	6.5	6.0	6.4	6.8
644	652	6	495(435)	495(415)	465(355)	6.7	6.9	7.3	6.8	7.1	7.6
744	752	7	595(535)	595(515)	565(455)	7.6	7.7	8.0	7.7	7.9	8.3

Note⁽¹⁾: This indicates the stroke length when limit sensors are attached. The values in () are for two slide tables in close contact.

⁽²⁾: The values indicate entire table mass with one slide table. The mass of motor is not included.

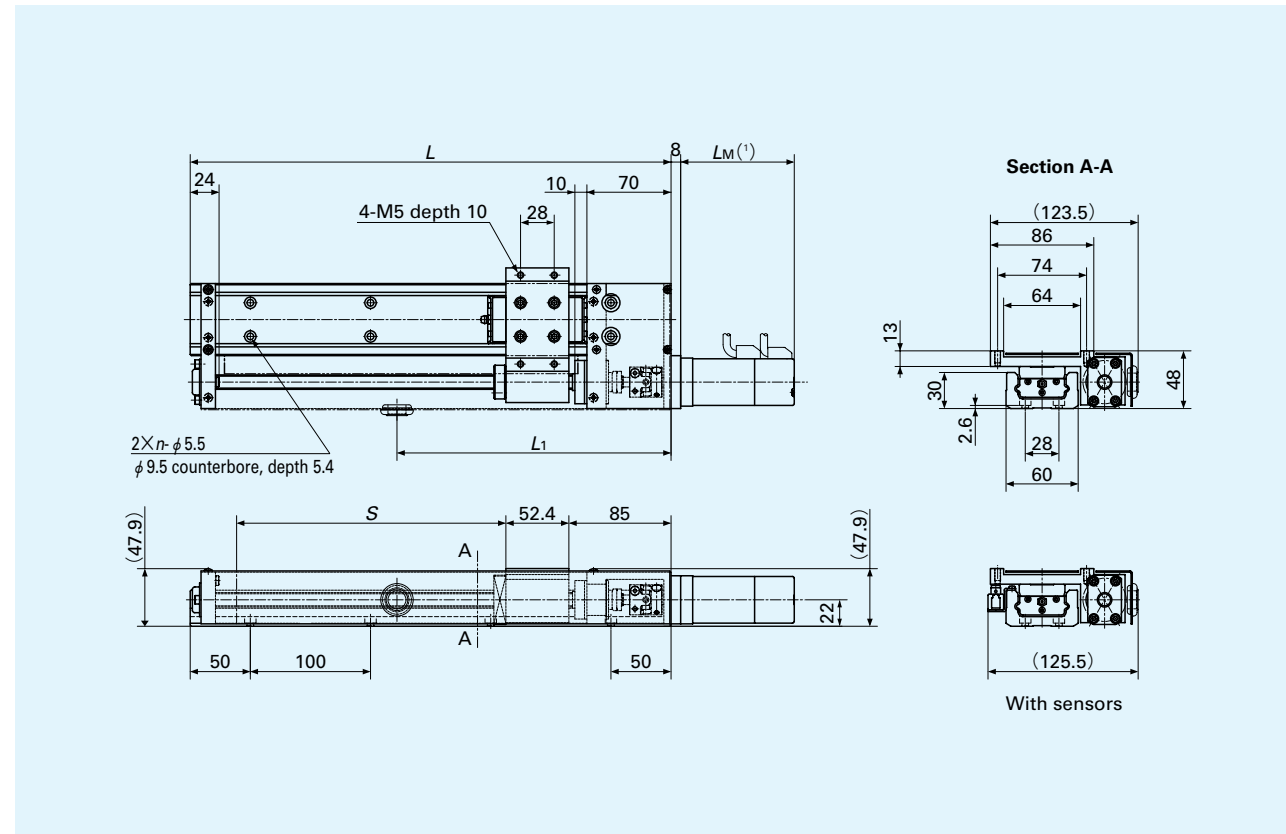

Note⁽¹⁾ : See the dimension table for the motor unit on page C-3.

Dimensions unit : mm

Track rail length <i>L</i>	<i>L</i> ₁	<i>n</i>	Stroke length <i>S</i> ⁽¹⁾	Mass of slide unit kg	Mass ⁽²⁾ kg
400	228	4	224	1.1	5.0
500	278	5	324		5.9
600	328	6	424		6.8

Note⁽¹⁾ : This indicates the limit stroke length when limit sensors are attached.

⁽²⁾ : The mass of motor is not included.

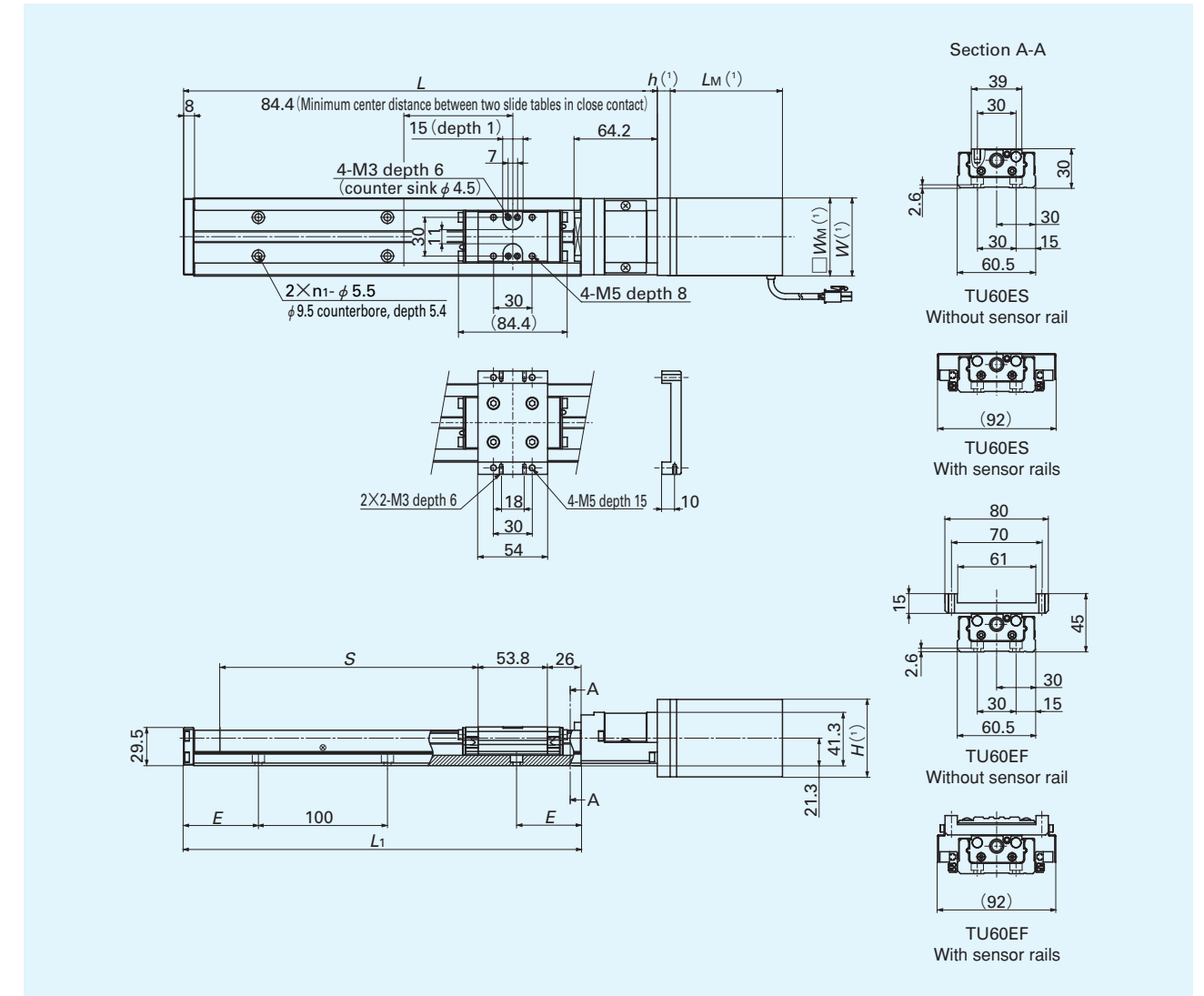

Note⁽¹⁾ : See the dimension table for the motor unit on page C-4.

Dimensions unit : mm

Model number	Track rail length <i>L</i> ₁	Total length <i>L</i>	Stroke length <i>S</i> ⁽¹⁾	<i>m</i> ₁	<i>E</i>	Mass of slide table kg	Mass ⁽²⁾ kg
TU60ES	150	217	50 (-)	2	25	0.29	1.55
	200	267	100 (-)	2	50		1.86
	300	367	200 (115)	3	50		2.50
	400	467	300 (215)	4	50		3.13
	500	567	400 (315)	5	50		3.77
	600	667	500 (415)	6	50		4.40
	700	767	600 (515)	7	50		5.04
TU60EF	750	817	650 (565)	8	25	0.39	5.36
	150	217	50 (-)	2	25		1.66
	200	267	100 (-)	2	50		1.98
	300	367	200 (115)	3	50		2.61
	400	467	300 (215)	4	50		3.25
	500	567	400 (315)	5	50		3.88
	600	667	500 (415)	6	50		4.52
	700	767	600 (515)	7	50		5.15
750	817	650 (565)	8	25	5.47		

Note⁽¹⁾ : This indicates the stroke length when limit sensors are attached. The values in () are for two slide tables in close contact.

⁽²⁾ : The values indicate entire table mass with one slide table. The mass of motor is not included.

1N=0.102kgf=0.2248lbs.
1mm=0.03937inch

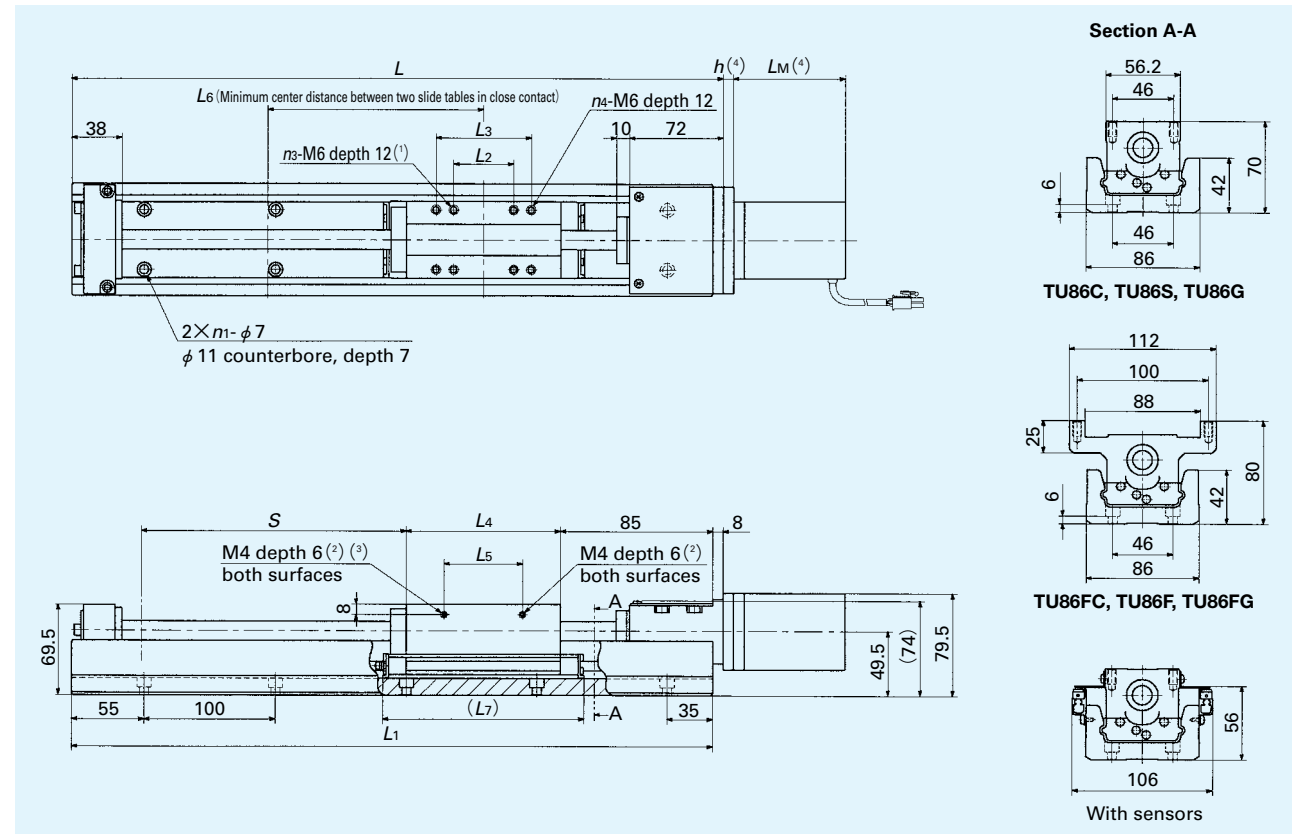

Note⁽¹⁾: M5 depth 12 in the case of TU86F
⁽²⁾: These threaded holes are not provided on TU86FC, TU86F and TU86FG.
⁽³⁾: $\phi 3$ depth 2 in the case of TU86C
⁽⁴⁾: See the dimension table for the motor unit on page C-1.

Dimensions of slide table

unit : mm

Model number	L ₂	L ₃	L ₄	L ₅	L ₆	L ₇	n ₃	n ₄	Mass kg
TU86C	—	—	43	30	90	80	2	—	0.7
TU86S	46	—	93	63	140	130	4	—	1.7
TU86G	46	73	118	60	165	155	4	4	2.2
TU86FC	—	—	43	—	90	80	2	—	1.1
TU86F	28	46	93	—	140	130	4	4	2.3
TU86FG	46	73	118	—	165	155	4	4	3.0

Dimensions of track rail

unit : mm

Track rail length L ₁	Total length L	n ₁	Stroke length S ⁽¹⁾			Mass ⁽²⁾ kg					
			TU86C TU86FC	TU86S TU86F	TU86G TU86FG	TU86C	TU86S	TU86G	TU86FC	TU86F	TU86FG
490	498	5	300 (220)	250 (120)	225 (70)	9.9	10.9	11.4	10.3	11.5	12.2
590	598	6	400 (320)	350 (220)	325 (170)	10.8	11.7	12.2	11.2	12.4	13.0
690	698	7	500 (420)	450 (320)	425 (270)	12.3	13.2	13.8	12.7	13.9	14.6
790	798	8	600 (520)	550 (420)	525 (370)	13.8	14.7	15.3	14.2	15.4	16.1
890	898	9	700 (620)	650 (520)	625 (470)	15.0	15.9	16.4	15.4	16.6	17.2
990	998	10	800 (720)	750 (620)	725 (570)	16.5	17.4	17.9	16.9	18.1	18.7
1090	1098	11	900 (820)	850 (720)	825 (670)	18.0	18.9	19.4	18.4	19.6	20.2
1190	1198	12	1000 (920)	950 (820)	925 (770)	19.5	20.4	21.0	19.9	21.1	21.8
1390	1398	14	1200 (1120)	1150 (1020)	1125 (970)	24.5	25.4	25.9	24.9	26.0	26.7
1590	1598	16	1400 (1320)	1350 (1220)	1325 (1170)	27.8	28.7	29.2	28.2	29.3	30.0

Note⁽¹⁾: This indicates the stroke length when limit sensors are attached. The values in () are for two slide tables in close contact.
⁽²⁾: The values indicate entire table mass with one slide table. The mass of motor is not included.

Motor folding back specification

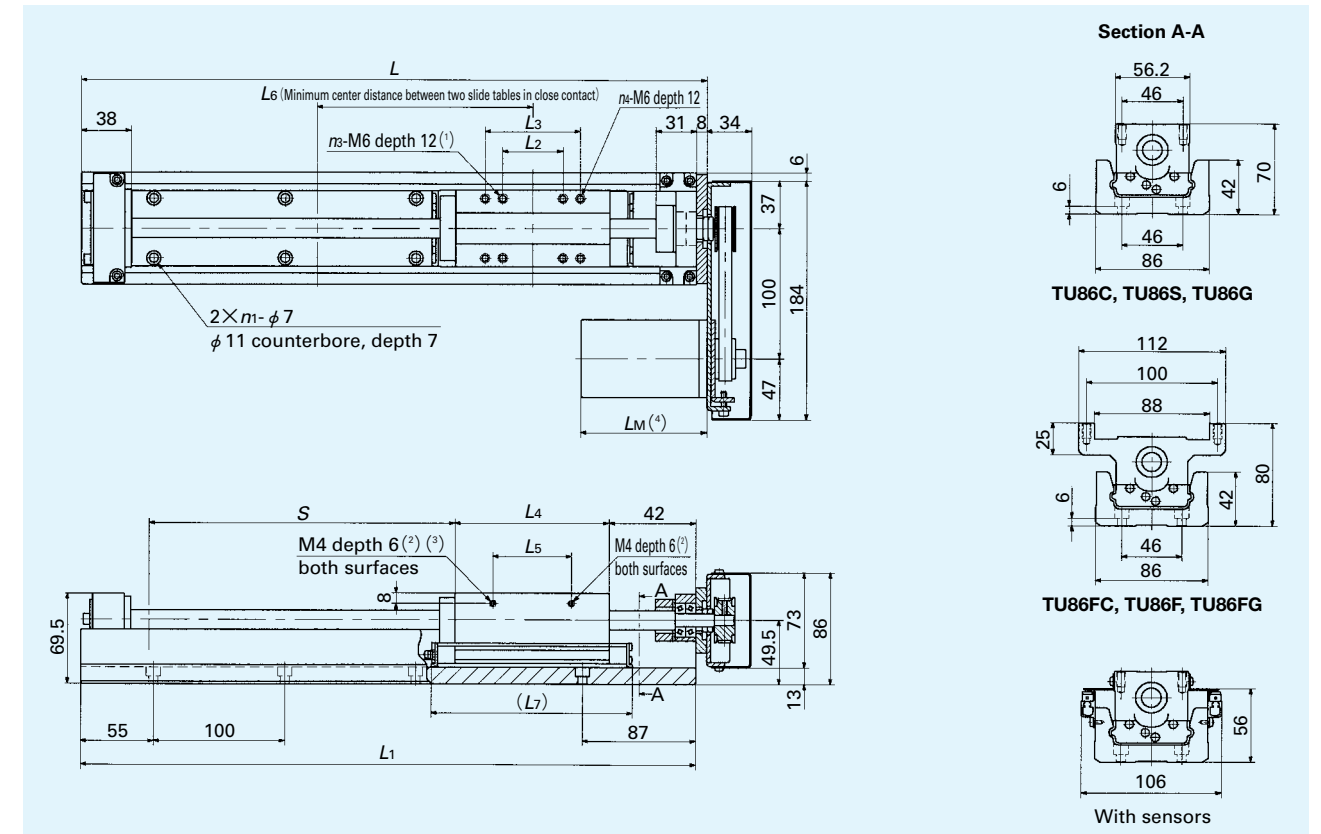

Note⁽¹⁾: M5 depth 12 in the case of TU86F
⁽²⁾: These threaded holes are not provided on TU86FC, TU86F and TU86FG.
⁽³⁾: $\phi 3$ depth 2 in the case of TU86C
⁽⁴⁾: See the dimension table for the motor unit on page C-1.

Dimensions of slide table

unit : mm

Model number	L ₂	L ₃	L ₄	L ₅	L ₆	L ₇	n ₃	n ₄	Mass kg
TU86C	—	—	43	30	90	80	2	—	0.7
TU86S	46	—	93	63	140	130	4	—	1.7
TU86G	46	73	118	60	165	155	4	4	2.2
TU86FC	—	—	43	—	90	80	2	—	1.1
TU86F	28	46	93	—	140	130	4	4	2.3
TU86FG	46	73	118	—	165	155	4	4	3.0

Dimensions of track rail

unit : mm

Track rail length L ₁	Total length L	n ₁	Stroke length S ⁽¹⁾			Mass ⁽²⁾ kg					
			TU86C TU86FC	TU86S TU86F	TU86G TU86FG	TU86C	TU86S	TU86G	TU86FC	TU86F	TU86FG
442	450	4	295 (215)	245 (115)	220 (65)	10.3	11.3	11.8	10.7	11.9	12.6
542	550	5	395 (315)	345 (215)	320 (165)	11.2	12.1	12.6	11.6	12.8	13.4
642	650	6	495 (415)	445 (315)	420 (265)	12.7	13.6	14.2	13.1	14.3	15.0
742	750	7	595 (515)	545 (415)	520 (365)	14.2	15.1	15.7	14.6	15.8	16.5
842	850	8	695 (615)	645 (515)	620 (465)	15.4	16.3	16.8	15.8	17.0	17.6
942	950	9	795 (715)	745 (615)	720 (565)	16.9	17.8	18.3	17.3	18.5	19.1
1042	1050	10	895 (815)	845 (715)	820 (665)	18.4	19.3	19.8	18.8	20.0	20.6
1142	1150	11	995 (915)	945 (815)	920 (765)	19.9	20.8	21.4	20.3	21.5	22.2

Note⁽¹⁾: This indicates the stroke length when limit sensors are attached. The values in () are for two slide tables in close contact.
⁽²⁾: The values indicate entire table mass with one slide table. The mass of motor is not included.

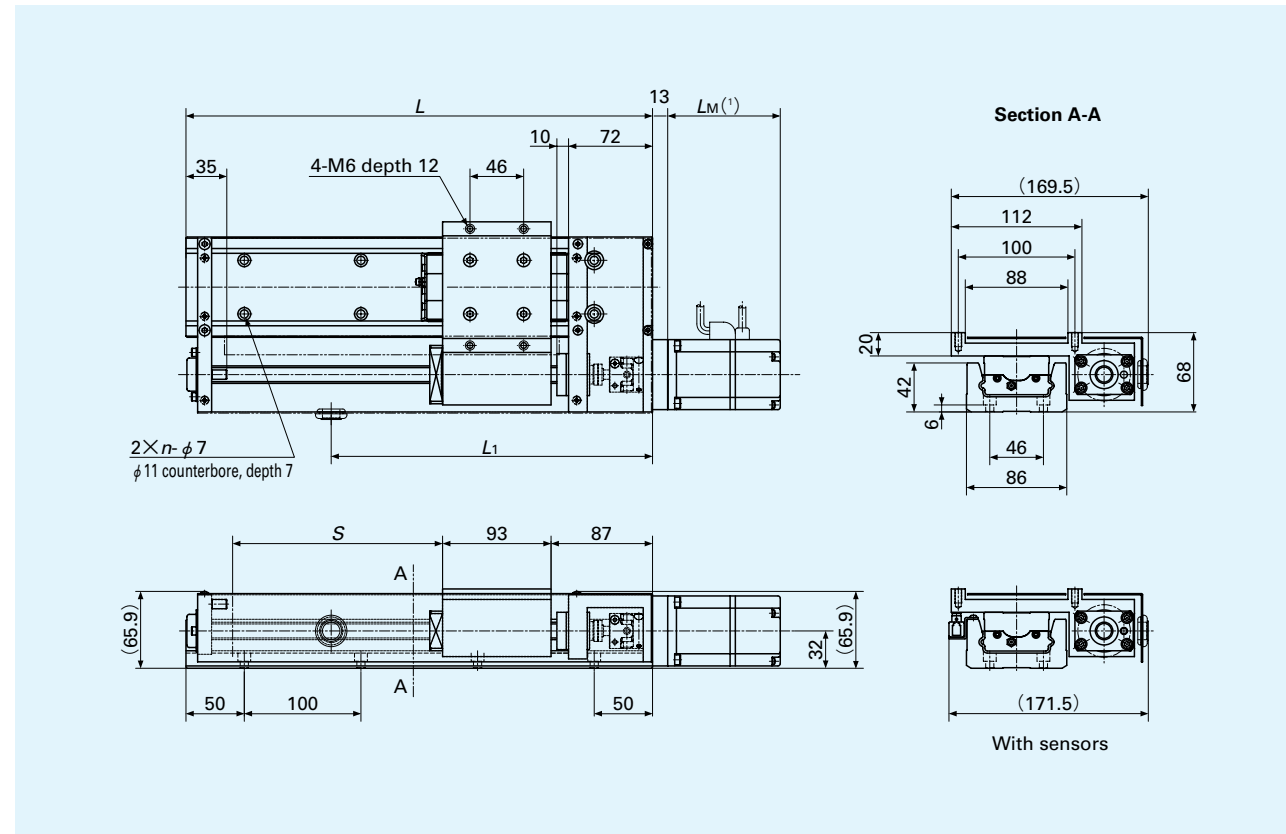

Note⁽¹⁾: See the dimension table for the motor unit on page C-3.

Dimensions unit : mm

Track rail length L	L ₁	n	Stroke length S ⁽¹⁾	Mass of slide unit kg	Mass ⁽²⁾ kg
400	275.5	4	180	3.5	11.5
600	375.5	6	380		14.9
800	475.5	8	580		18.4

Note⁽¹⁾: This indicates the stroke length when limit sensors are attached.
 Note⁽²⁾: The mass of motor is not included.

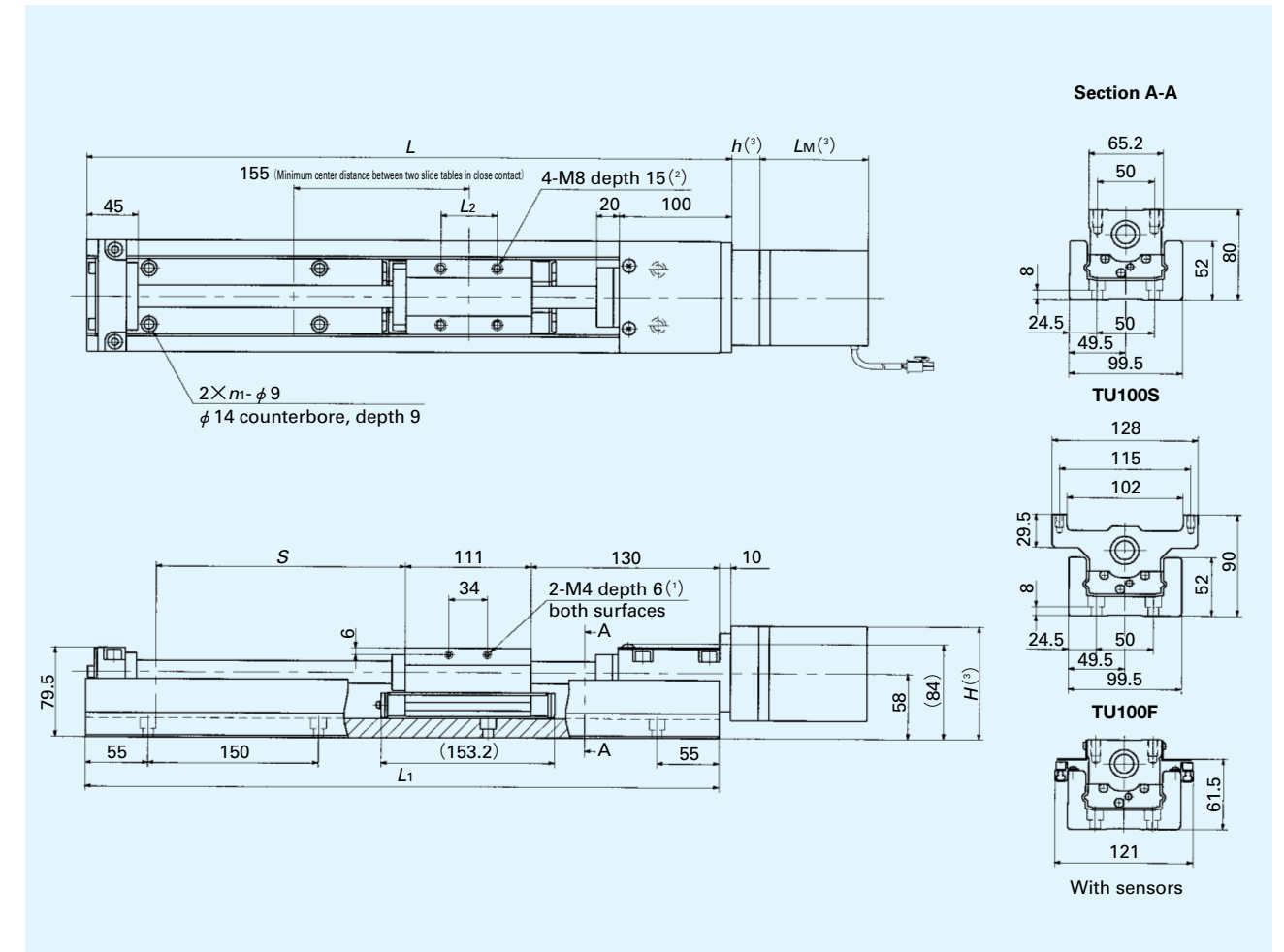

Note⁽¹⁾: These threaded holes are not provided on TU100F.

Note⁽²⁾: M6 depth 12 in the case of TU100F

Note⁽³⁾: See the dimension table for the motor unit on page C-1.

Remark: The track rail is provided with threaded holes of M12 hanging bolts for ease of transportation.

Dimensions unit : mm

Model number	Track rail length L ₁	Total length L	Stroke length S ⁽¹⁾	n ₁	L ₂	Mass ⁽²⁾ kg
TU100S	1010	1020	690 (550)	7	50	28.0
	1160	1170	840 (700)	8		31.6
	1310	1320	990 (850)	9		35.1
	1460	1470	1140 (1000)	10		38.8
TU100F	1010	1020	690 (550)	7	46	29.1
	1160	1170	840 (700)	8		32.7
	1310	1320	990 (850)	9		36.2
	1460	1470	1140 (1000)	10		39.9

Note⁽¹⁾: This indicates the stroke length when limit sensors are attached. The values in () are for two slide tables in close contact.

Note⁽²⁾: The values indicate entire table mass with one slide table. The mass of motor is not included.

Mass of one slide table : TU100S 2.6kg, TU100F 3.7kg

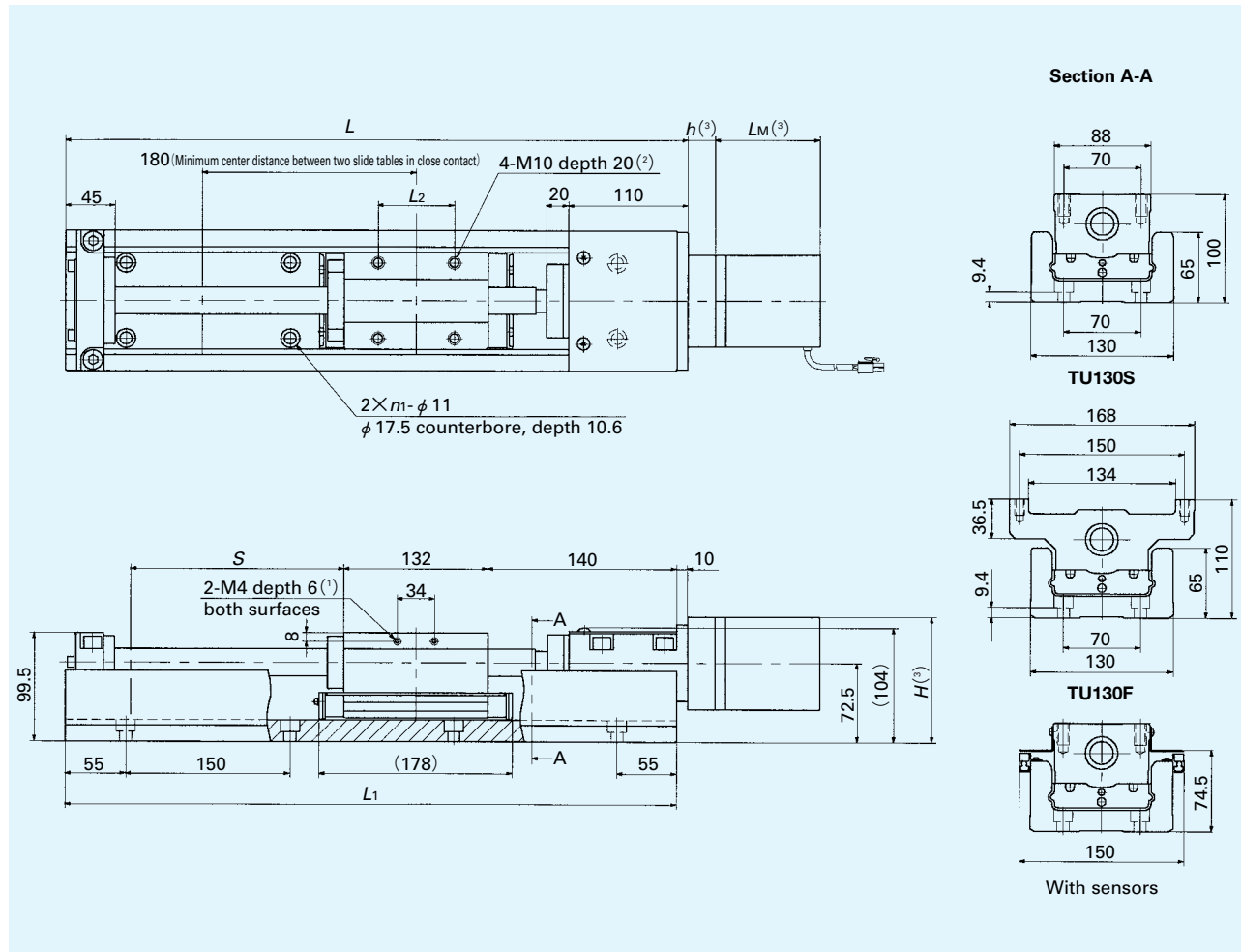

Note(1) : These threaded holes are not provided on TU130F.

(2) : M8 depth 15 in the case of TU130F

(3) : See the dimension table for the motor unit on page C-1.

Remark : The track rail is provided with threaded holes of M12 hanging bolts for ease of transportation.

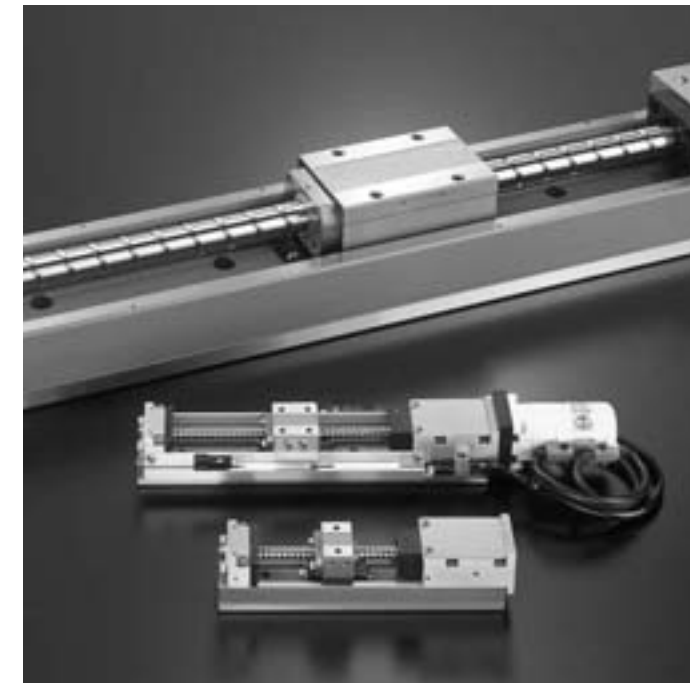

Dimensions

unit : mm

Model number	Track rail length L_1	Total length L	Stroke length $S^{(1)}$	m_1	L_2	Mass ⁽²⁾ kg
TU130S	1010	1020	660(490)	7	70	45.2
	1160	1170	810(640)	8		50.6
	1310	1320	960(790)	9		56.2
	1460	1470	1110(940)	10		61.8
	1610	1620	1260(1090)	11		67.3
TU130F	1010	1020	660(490)	7	50	47.6
	1160	1170	810(640)	8		53.0
	1310	1320	960(790)	9		58.6
	1460	1470	1110(940)	10		64.2
	1610	1620	1260(1090)	11		69.7

Note(1) : This indicates the stroke length when limit sensors are attached. The values in () are for two slide tables in close contact.

(2) : The values indicate entire table mass with one slide table. The mass of motor is not included.

Mass of one slide table : TU130S 5.4kg, TU130F 7.8kg

Dimensions of Motor and Attachment

In  Precision Positioning Table TU series, stepper motor or AC servomotor, with brake or without brake can be easily selected to suit various application.

Table 22, 24, and 26 show the dimensions of the motor and attachment. Table 23, 25, and 27 show the specifications when the motor attachment and coupling are not required.

Table 22 Dimension of motor part on TU

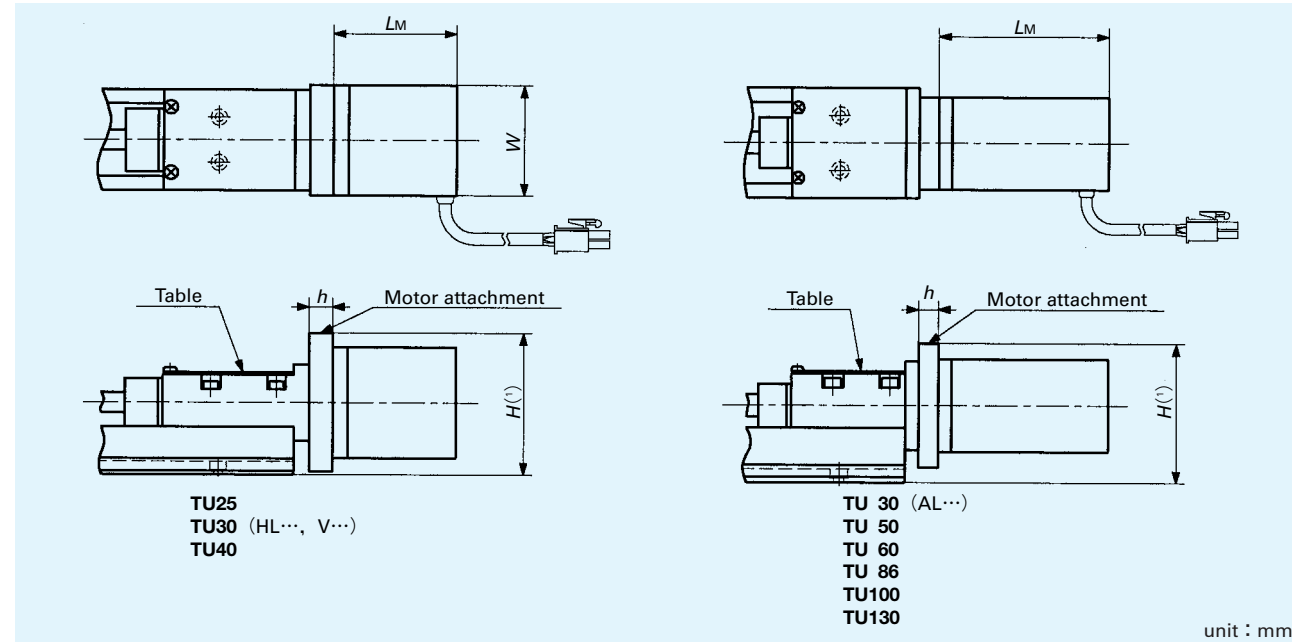

Model	With or without brake	AC servo motor								Stepper motor							
		AL...				HL...				V004							
		h	H ⁽¹⁾	W	L _M	h	H ⁽¹⁾	W	L _M	h	H ⁽¹⁾	W	L _M				
TU 25	Without brake	5		25	64	5		30	61	6.5		28	32				
	With brake	5		25	92.5	5		30	88	—		—	—				
TU 30	Without brake	5		—	64	5		30	61	6.5		28	32				
	With brake	5		—	92.5	5		30	88	—		—	—				
Model	With or without brake	AC servo motor								Stepper motor							
		Y...				P...				J...				V...			
		h	H	W	L _M	h	H	W	L _M	h	H	W	L _M	h	H	W	L _M
TU 40	Without brake	9	48.5	40	77	9	48.5	38	73	9	48.5	40	81.5	9	56.5	42	47
	With brake	9	48.5	40	108.5	9	48.5	38	105	9	48.5	40	109.5	9	56.5	42	77
TU 50	Without brake	9	55	40	77	9	55	38	73	9	55	40	81.5	9	63	—	47
	With brake	9	55	40	108.5	9	55	38	105	9	55	40	109.5	9	63	—	77
TU 60	Without brake	8	72	40	94.5	8	72	38	103	8	72	40	96.5	8	72	—	87
	With brake	8	72	40	135	8	72	38	135	8	72	40	124.5	8	72	—	129
TU 86	Without brake	13	79.5	60	96.5	13	79.5	60	94	13	79.5	60	99.5	8	79.5	—	87
	With brake	13	79.5	60	136	13	79.5	60	127	13	79.5	60	131.5	8	79.5	—	129
TU100	Without brake	7	93	60	124.5	7	93	60	123.5	7	93	60	124.5	25	100.5	—	96
	With brake	7	93	60	164	7	93	60	156.5	7	93	60	156.5	25	100.5	—	149
TU130	Without brake	17	112.5	60	145	17	112.5	80	142.5	17	112.5	80	142	25	115	—	96
	With brake	17	112.5	60	189.5	17	112.5	80	177.5	17	112.5	80	177.5	25	115	—	149

Note⁽¹⁾: The dimension H of TU25 and TU30 is lower than table height.

Remarks 1: For the dimensions of the slide table and the track rail, see the dimension tables from page B-1.

2: For Low profile type (TU...YF), see Table 24.

3: For Compact type (TU...E), see Table 26.

Table 23 Mounting dimension for motor attachment of TU

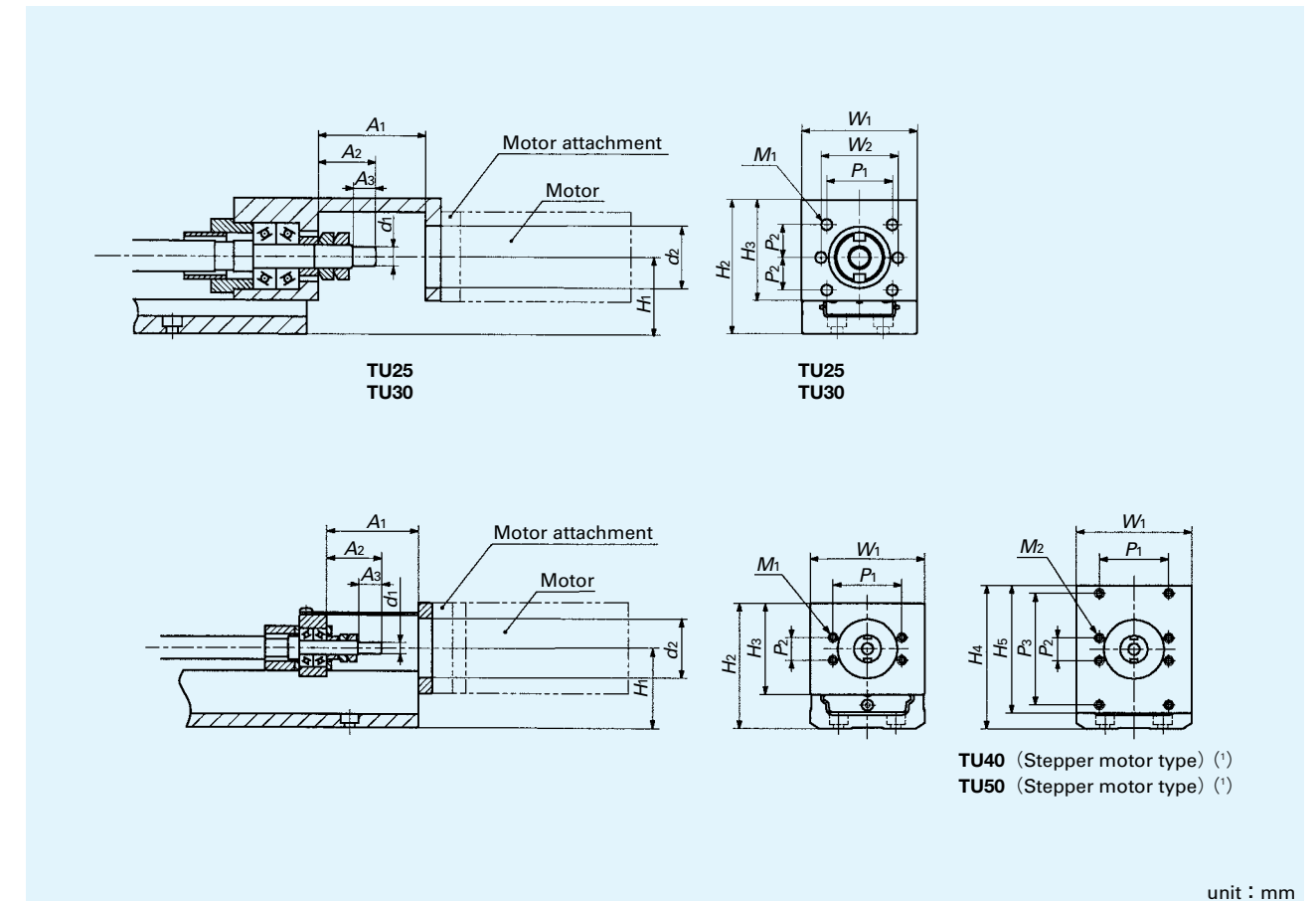

Model	A ₁	A ₂	A ₃	d ₁	d ₂	H ₁	H ₂	H ₃	H ₄	H ₅	unit : mm			
											W ₁	W ₂	P ₁	P ₂
TU 25	28	15	6	φ 5 _{-0.008} ⁰	φ 16 _{+0.02} ^{+0.04}	16	31	26.3	—	—	—	—	—	—
TU 30	28	15	6	φ 5 _{-0.008} ⁰	φ 16 _{+0.02} ^{+0.04}	20	35	26.3	—	—	—	—	—	—
TU 40	40	24	10	φ 5 _{-0.008} ⁰	φ 26 _{+0.02} ^{+0.04}	28.5	43.5	30	56.5	56	—	—	—	—
TU 50	40	24	10	φ 5 _{-0.008} ⁰	φ 26 _{+0.02} ^{+0.04}	35	55	40	63	56	—	—	—	—
TU 60	46	29	15	φ 8 _{-0.009} ⁰	φ 32 _{+0.02} ^{+0.04}	42	62	40	—	—	—	—	—	—
TU 86	48	29	15	φ 8 _{-0.009} ⁰	φ 39 _{+0.02} ^{+0.04}	49.5	74.5	50	—	—	—	—	—	—
TU100	72	44	22	φ 12 _{-0.011} ⁰	φ 59 _{+0.02} ^{+0.04}	58	93	70	—	—	—	—	—	—
TU130	72	44	20	φ 15 _{-0.011} ⁰	φ 59 _{+0.02} ^{+0.04}	72.5	107.5	70	—	—	—	—	—	—
Model	W ₁	W ₂	P ₁	P ₂	P ₃	M ₁	M ₂							
TU 25	25	20	17	8.5	—	6-φ 2.9	—							
TU 30	30	20	17	8.5	—	6-φ 2.9	—							
TU 40	40	—	30	10	49	4-M3 depth 6	8-M3 depth 6							
TU 50	50	—	30	10	49	4-M3 depth 6	8-M3 depth 6							
TU 60	57.7	—	50	20	—	4-M4 depth 8	—							
TU 86	83.6	—	50	20	—	4-M4 depth 8	—							
TU100	98	—	72	40	—	4-M5 depth 10	—							
TU130	128	—	72	40	—	4-M5 depth 10	—							

Note⁽¹⁾: When the stepper motor type without motor attachment is required, consult  for further information.

Remarks 1: For dimensions of the slide table and track rail, see the dimension tables from page B-1.

2: For Low profile type, see Table 25.

3: For Compact type, see Table 27.

Table 24 Dimension of motor part on TU...YF (Low profile type)

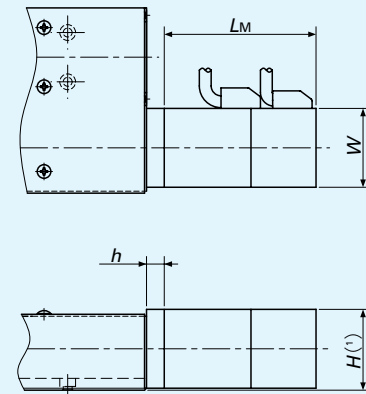

unit : mm

Model	With or without brake	AC servo motor											
		Y...				P...				J...			
		<i>h</i>	<i>H</i> (¹)	<i>W</i>	<i>L_M</i>	<i>h</i>	<i>H</i> (¹)	<i>W</i>	<i>L_M</i>	<i>h</i>	<i>H</i> (¹)	<i>W</i>	<i>L_M</i>
TU50YF	Without brake	9	41	40	77	9	41	38	73	9	41	40	81.5
	With brake				108.5				105				109.5
TU60YF	Without brake	8	—	40	94.5	8	—	38	103	8	—	40	96.5
	With brake				135				135				124.5
TU86YF	Without brake	13	—	60	96.5	13	—	60	94	13	—	60	99.5
	With brake				136				127				131.5

Note(¹) : The dimension *H* of TU60YF and TU86YF is lower than height of table.

Remark : For dimensions of the slide table and track rail, see the dimension tables from page B-1.

Table 25 Mounting dimension for motor attachment of TU...YF (Low profile type)

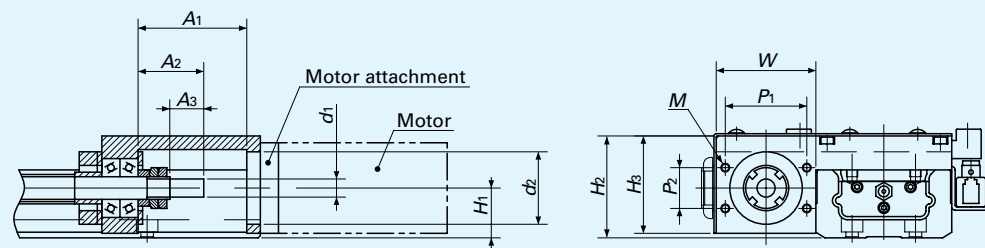

unit : mm

Model	<i>A₁</i>	<i>A₂</i>	<i>A₃</i>	<i>d₁</i>	<i>d₂</i>	<i>H₁</i>
TU50YF	40	24	10	$\phi 5_{-0.008}^0$	$\phi 26_{+0.02}^{+0.04}$	21
TU60YF	48	29	15	$\phi 8_{-0.009}^0$	$\phi 32_{+0.02}^{+0.04}$	22
TU86YF	48	29	15	$\phi 8_{-0.009}^0$	$\phi 39_{+0.02}^{+0.04}$	32
Model	<i>H₂</i>	<i>H₃</i>	<i>W</i>	<i>P₁</i>	<i>P₂</i>	<i>M</i>
TU50YF	37.5	36.5	43	30	10	4-M3 depth 6
TU60YF	45	43	44	36	18	4-M4 depth 6
TU86YF	63	57.5	64	50	20	4-M4 depth 8

Remark : For dimensions of the slide table and track rail, see the dimension tables from page B-1.

Table 26 Dimension of motor part on TU...E (Low profile type)

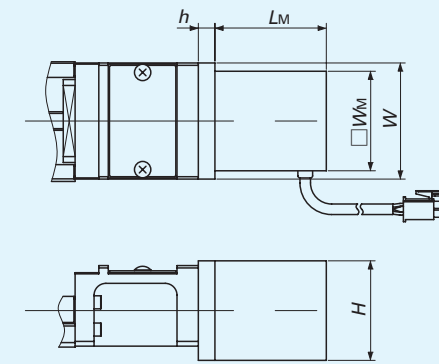

unit : mm

Model	Motor code	<i>h</i>	<i>H</i>	<i>W</i>	$\square W_M$	<i>L_M</i>
TU50E	Y027 (Y032)	10.5	40	40	40	77.0(108.5)
	P001 (P006)	10.5	38	38	38	73.0(105.0)
	J001 (J006)	10.5	40	40	40	81.5(109.5)
	V005 (V006)	7	42	49	42	47.0(77.0)
TU60E	Y028 (Y033)	10	40	42	40	94.5(135.0)
	P002 (P007)	10	40	42	38	103.0(135.0)
	J002 (J007)	10	40	42	40	96.5(124.5)
	V011 (V012)	10	60	60	60	89.0(129.0)

Remarks 1 : The dimensions *h*, *H*, and *W* show the dimension of motor attachment.

2 : The values in () show the dimension of motor with brake.

Fig 27 Mounting dimension for motor attachment of TU...E (Low profile type)

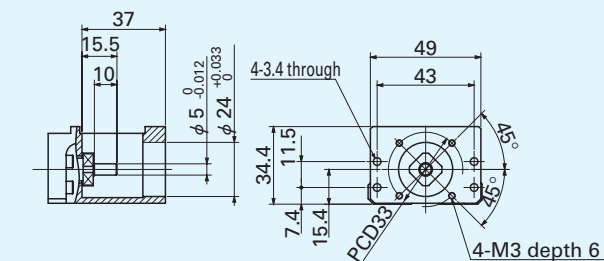

TU50E

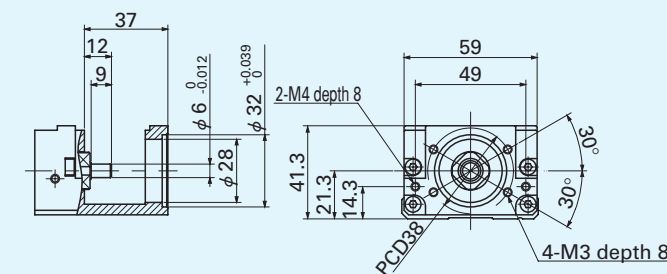

TU60E

Motor attachment for NEMA Specification

The following motor attachments are available for NEMA specification. Please consult IKO for further information.

Table 28 Motor attachment for NEMA specification

Model	NEMA Flange No.	Attachment part number	NEMA shaft No.	Motor shaft diameter	
				(mm)	(inch)
TU 25, TU 30	(11C)	/V004	020	5.00	0.1969
	17C	TAE9065-ATE063			
TU 40, TU 50	23D	/V005	025	6.35	0.2500
TU 60		TAE9014-ATE41			
TU 86	34D	TAE9017-ATE058	038	9.53	0.3750
TU100, TU130	42D	TAE9056-ATE45			
		TAE9047-ATE062			
		TAE9047-ATE060	063	15.88	0.6250

● Motor attachment for NEMA specification

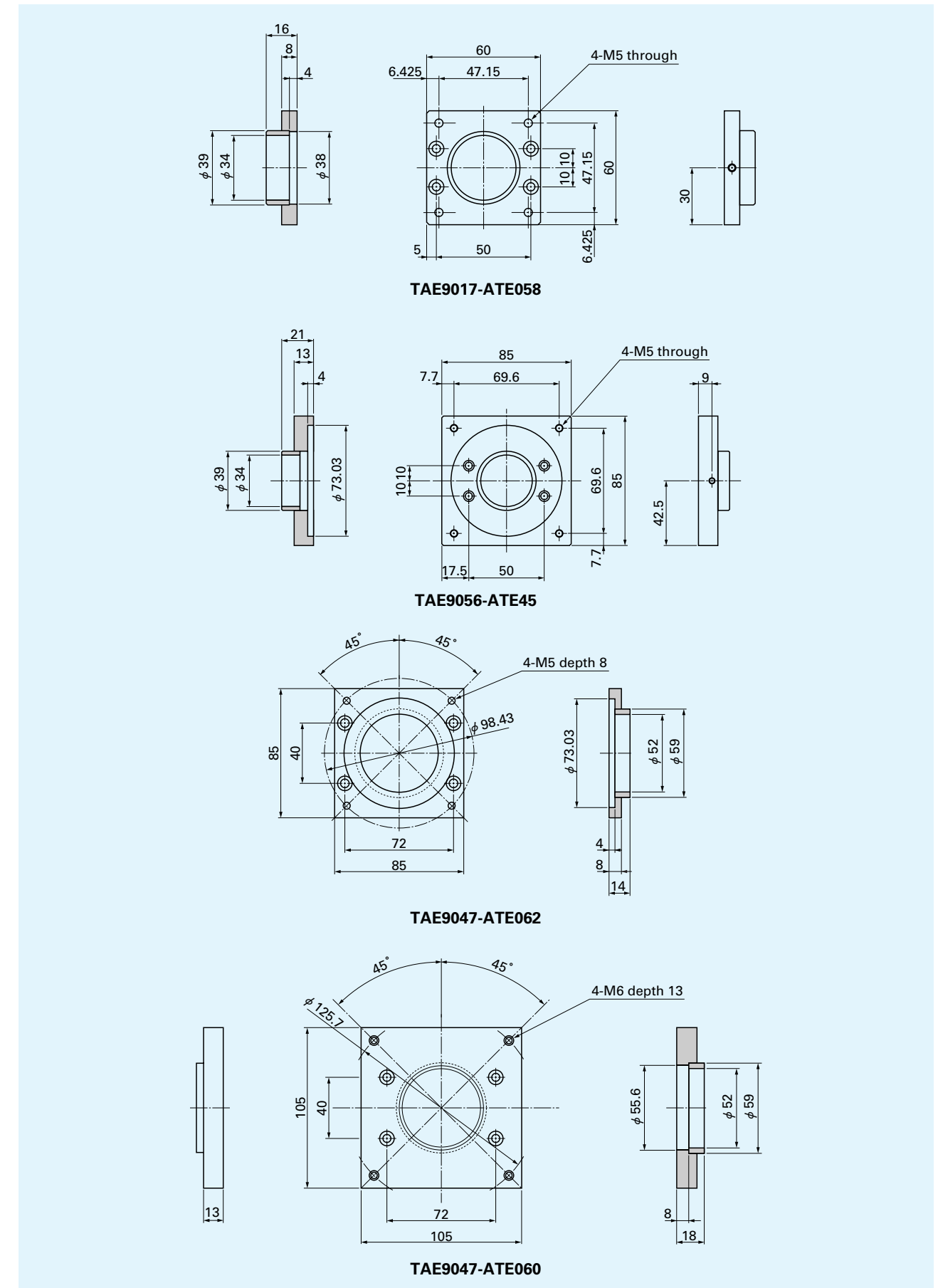
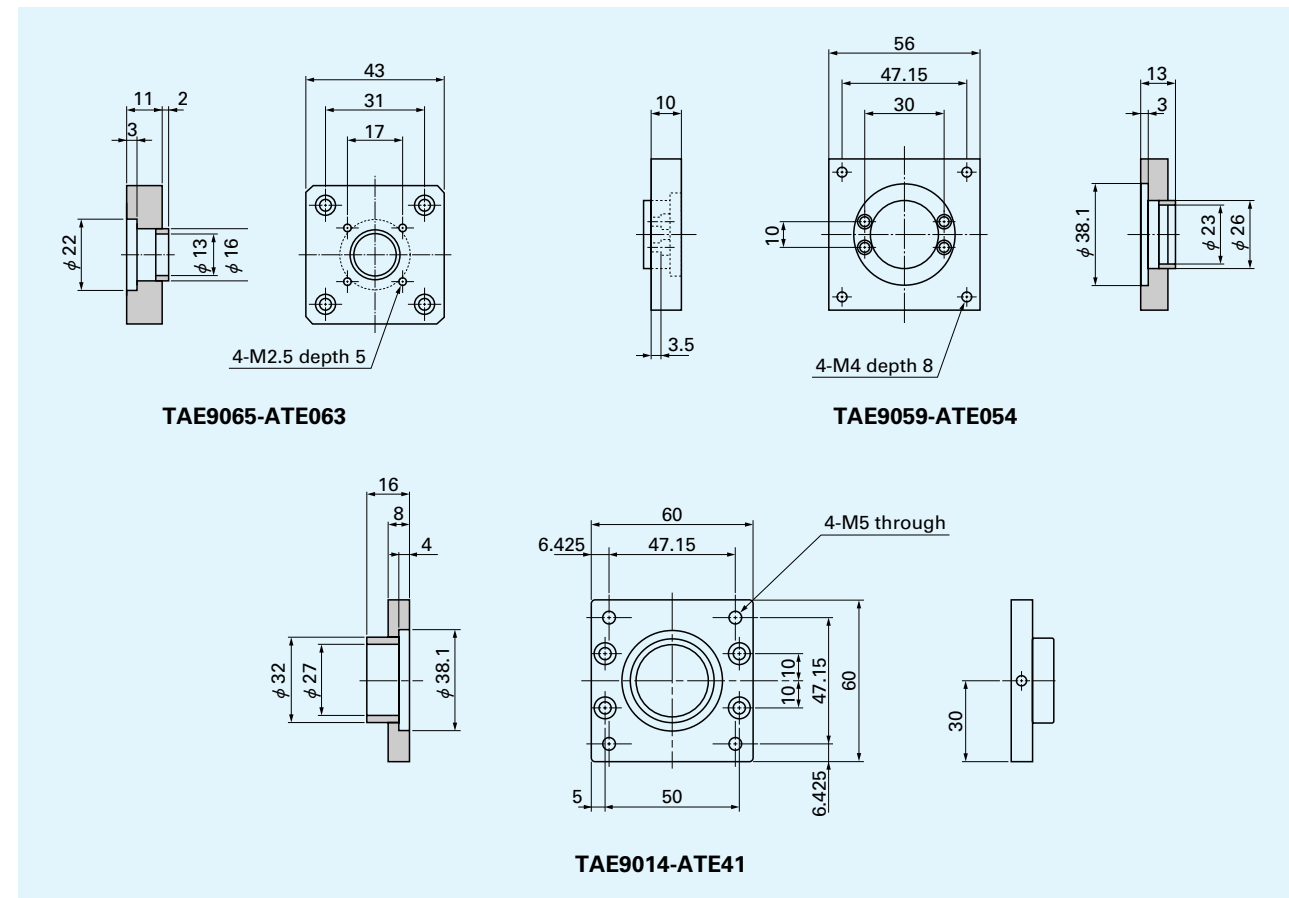

Specification of Yaskawa AC servo motor (RoHS compliant)

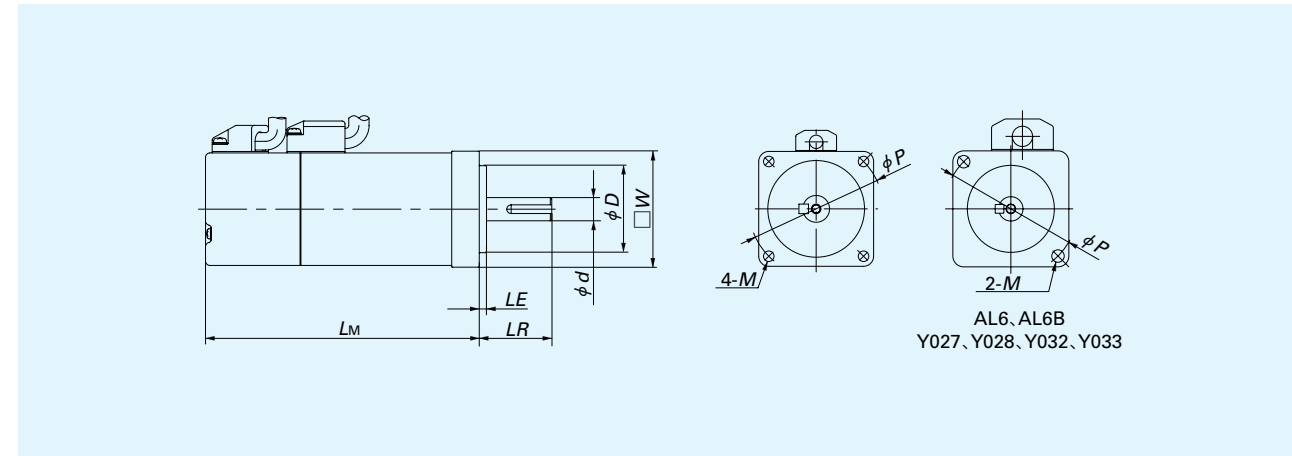

Motor specifications

Motor code	Motor Model number	Power supply voltage V	Rated output W	Rated torque N·m	Instantaneous maximum torque N·m	Rated number of revolution r/min	Motor inertia Jm ×10 ⁻⁴ kg·m ²	Encoder specification	Mass kg
AL6 ⁽¹⁾	SGMM-A2C312	24	20	0.0637	0.191	3000	0.00548	Incremental	0.16
AL6B ⁽¹⁾	SGMM-A2C312C		20	0.0637	0.191		0.00673	2048pulse/rev	0.26
Y027	SGMAH-A5AAA21-E	200	50	0.159	0.477		0.0220	Incremental 13bits (8192pulse/rev)	0.4
Y028	SGMAH-01AAA21-E		100	0.318	0.955		0.0364		0.5
Y029	SGMAH-02AAA21-E		200	0.637	1.91		0.106		1.1
Y030	SGMAH-04AAA21-E		400	1.27	3.82		0.173		1.7
Y031	SGMAH-08AAA21-E		750	2.39	7.16		0.672		3.4
Y032	SGMAH-A5AAA2C-E		50	0.159	0.477		0.0305		0.7
Y033	SGMAH-01AAA2C-E		100	0.318	0.955		0.0449		0.8
Y034	SGMAH-02AAA2C-E		200	0.637	1.91		0.164		1.6
Y035	SGMAH-04AAA2C-E		400	1.27	3.82		0.231		2.2
Y036	SGMAH-08AAA2C-E		750	2.39	7.16		0.812		4.3
Y039	SGMAS-02ACA21-E		200	0.637	1.91		0.116		0.9
Y040	SGMAS-04ACA21-E		400	1.27	3.82		0.190		1.2
Y041	SGMAS-06ACA21-E		600	1.91	5.73		0.326		1.7
Y042	SGMAS-08ACA21-E		750	2.39	7.16		0.769		2.5
Y043	SGMAS-02ACA2C-E	200	0.637	1.91	0.180		1.5		
Y044	SGMAS-04ACA2C-E	400	1.27	3.82	0.254		1.8		
Y045	SGMAS-06ACA2C-E	600	1.91	5.73	0.390		2.4		
Y046	SGMAS-08ACA2C-E	750	2.39	7.16	0.940		3.2		

Note⁽¹⁾ : Not conformed to the RoHS Directive.

Motor mounting dimensions

unit : mm

Motor code	□WXLM	LR	LE	d	D	P	M	Motor code	□WXLM	LR	LE	d	D	P	M
AL6	25×64	16	2.5	5	20	28	M3 depth 5	Y035	60×164	30	3	14	50	70	φ5.5
AL6B	25×92.5	16	2.5	5	20	28	M3 depth 5	Y036	80×189.5	40	3	16	70	90	φ7
Y027	40×77	25	2.5	6	30	46	φ4.3	Y039	60×80	30	3	14	50	70	φ5.5
Y028	40×94.5	25	2.5	8	30	46	φ4.3	Y040	60×98.5	30	3	14	50	70	φ5.5
Y029	60×96.5	30	3	14	50	70	φ5.5	Y041	60×124.5	30	3	14	50	70	φ5.5
Y030	60×124.5	30	3	14	50	70	φ5.5	Y042	80×115	40	3	16	70	90	φ7
Y031	80×145	40	3	16	70	90	φ7	Y043	60×120	30	3	14	50	70	φ5.5
Y032	40×108.5	25	2.5	6	30	46	φ4.3	Y044	60×138.5	30	3	14	50	70	φ5.5
Y033	40×135	25	2.5	8	30	46	φ4.3	Y045	60×172	30	3	14	50	70	φ5.5
Y034	60×136	30	3	14	50	70	φ5.5	Y046	80×160	40	3	16	70	90	φ7

Specification of Yaskawa AC servo driver (RoHS compliant)

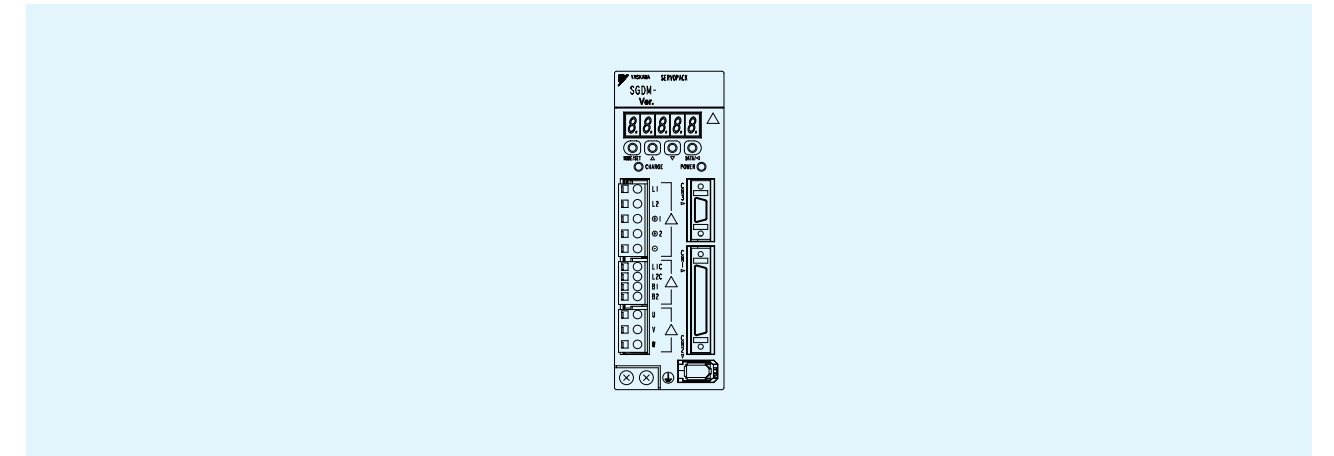

Driver specifications

Model number of driver	SGDF-A2CP ⁽¹⁾	SGDH-A5AE-E	SGDH-01AE-E	SGDH-02AE-E	SGDH-04AE-E	SGDH-08AE-E	SGDS-02A02A-E	SGDS-04A02A-E	SGDS-08A02A-E	
Applicable motor code	AL6 AL6B	Y027 Y032	Y028 Y033	Y029 Y034	Y030 Y035	Y031 Y036	Y039 Y043	Y040 Y044	Y041 Y045	Y042 Y046
Rated output	20W	50W	100W	200W	400W	750W	200W	400W	600W	750W
Feed back	Incremental encoder	Serial encoder								
Command Input pulse	Selection one from symbol with pulse line, CCW or CW with pulse line, two phase pulse with 90-degree difference (A-phases or B-phases)									
Type of Command Input pulse	Line driver or Open collector						Line driver			
Main power supply voltage	DC24V ±10%	Single phase / Triphase AC200~230V -15~10% 50/60Hz					Single phase AC200~230V -15~10% 50/60Hz			
Control circuit supply voltage	Single phase AC200~230V -15~10% 50/60Hz									
Continuous rated current Arms	2.0	0.64	0.91	2.1	2.8	5.7	2.1	2.8	5.5	
Maximum consumption current Arms	5.7	2.0	2.8	6.5	8.5	13.9	6.5	8.5	16.9	
Ambient temperature in operation	0~50°C (Keep Freeze free)									
Ambient temperature in storage	-20~85°C (Keep Freeze free)									
Ambient temperature in operation and storage	90%RH or less (Keep dew drop free)									
Mass kg	0.3	0.8	0.8	0.8	1.1	1.7	0.7	0.9	1.4	

Note⁽¹⁾ : Not Conformed to the RoHS Directive.

Specification of Panasonic AC servo motor (RoHS compliant)

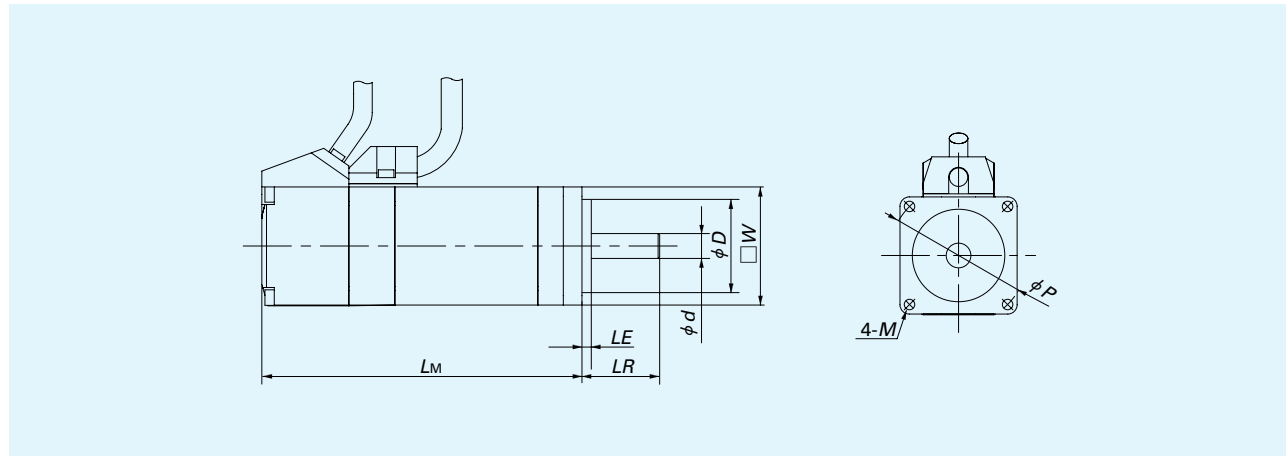

Motor specifications

Motor code	Motor Model number	Power supply voltage V	Rated output W	Rated torque N·m	Instantaneous maximum torque N·m	Rated number of revolution r/min	Motor inertia $J_M \times 10^{-4} \text{ kg} \cdot \text{m}^2$	Encoder specification pulse/rev	Mass kg
P001	MSMA5AZA1A	200	50	0.16	0.48	3000	0.025	Incremental 2500	0.34
P002	MSMA012A1A		100	0.32	0.95		0.062		0.56
P003	MSMA022A1A		200	0.64	1.91		0.17		1.0
P004	MSMA042A1A		400	1.3	3.8		0.36		1.6
P005	MSMA082A1A		750	2.4	7.1		1.31		3.2
P006	MSMA5AZA1B		50	0.16	0.48		0.030		0.53
P007	MSMA012A1B		100	0.32	0.95		0.066		0.76
P008	MSMA022A1B		200	0.64	1.91		0.20		1.4
P009	MSMA042A1B		400	1.3	3.8		0.39		2.0
P010	MSMA082A1B		750	2.4	7.1		1.39		3.9

Motor mounting dimensions

unit : mm

Motor code	□W×LM	LR	LE	d	D	P	M
P001	38×73	25	3	8	30	45	φ3.4
P002	38×103	25	3	8	30	45	φ3.4
P003	60×94	30	3	11	50	70	φ4.5
P004	60×123.5	30	3	14	50	70	φ4.5
P005	80×142.5	35	3	19	70	90	φ6
P006	38×105	25	3	8	30	45	φ3.4
P007	38×135	25	3	8	30	45	φ3.4
P008	60×127	30	3	11	50	70	φ4.5
P009	60×156.5	30	3	14	50	70	φ4.5
P010	80×177.5	35	3	19	70	90	φ6

Specification of Panasonic AC servo driver (RoHS compliant)

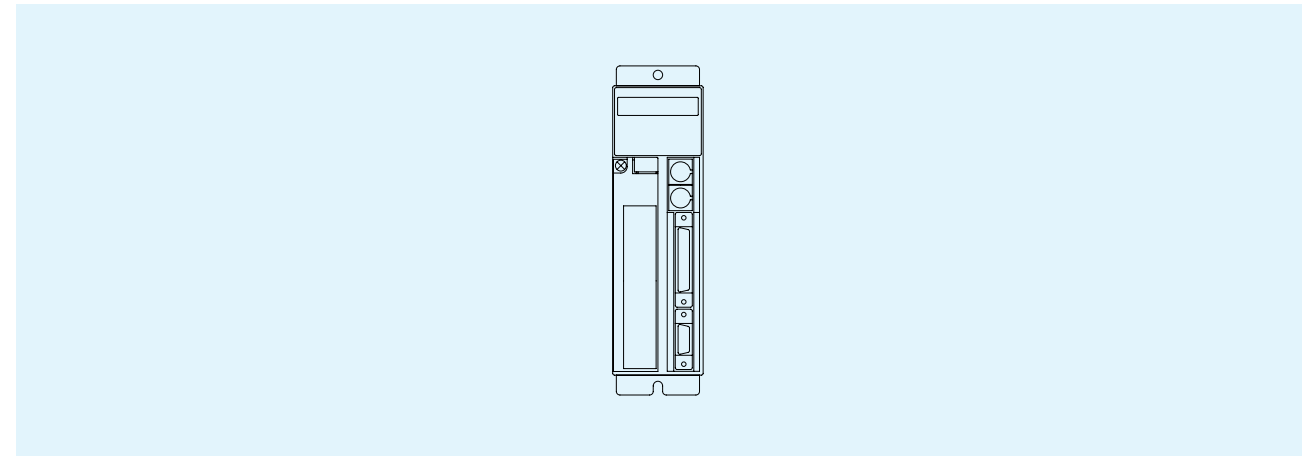

Driver specifications

Model number of driver	MSDA5A5A1A	MSDA015A1A	MSDA023A1A	MSDA043A1A	MSDA083A1A
Applicable motor code	P001、P006	P002、P007	P003、P008	P004、P009	P005、P010
Rated output	50W	100W	200W	400W	750W
Feed back	Incremental encoder 2500pulse/rev				
Command Input pulse	Selection one from symbol with pulse line, CCW or CW with pulse line, two phase pulse with 90-degree difference (A-phases or B-phases)				
Type of Command Input pulse	Line driver or Open collector				
Main power supply voltage	Single phase / Triphase AC200V~230V -15~10% 50/60Hz		Triphase AC200V~230V -15~10% 50/60Hz		
Control circuit supply voltage	Single phase AC200V~230V -15~10% 50/60Hz				
Power supply capacity kVA	0.3	0.3	0.5	0.9	1.3
Ambient temperature in operation	0~55°C (Keep Freeze free)				
Ambient temperature in storage	-20~85°C (Keep Freeze free)				
Ambient temperature in operation and storage	90%RH or less (Keep Freeze free)				
Mass kg	1.0	1.0	1.0	1.1	1.4

Specification of Mitsubishi AC servo motor (RoHS compliant)

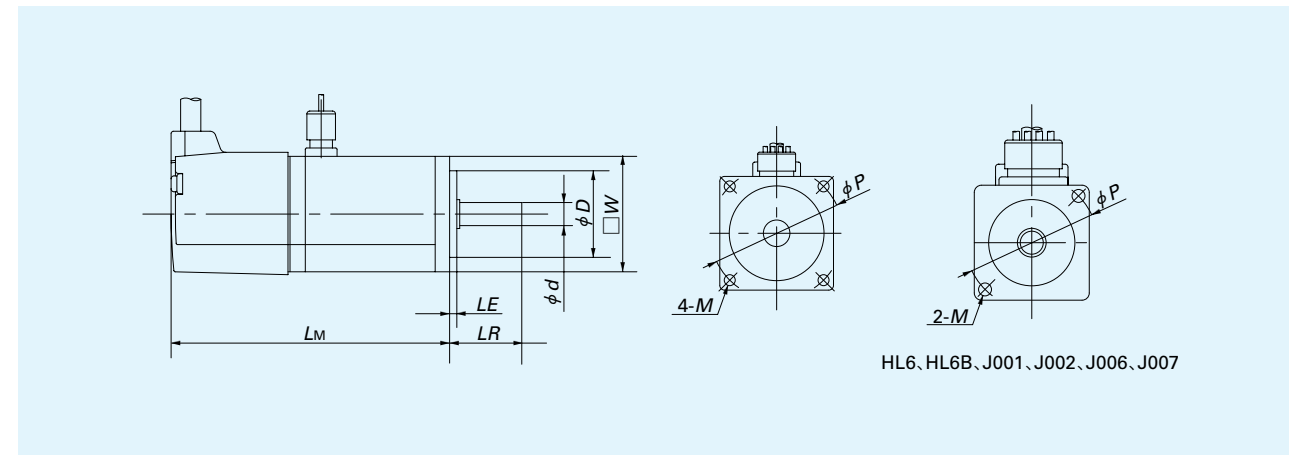

Motor specifications

Motor code	Motor Model number	Power supply voltage V	Rated output W	Rated torque N·m	Instantaneous maximum torque N·m	Rated number of revolution r/min	Motor inertia $J_M \times 10^{-4} \text{ kg} \cdot \text{m}^2$	Encoder specification pulse/rev	Mass kg
HL6	HC-AQ0235D	24	20	0.0637	0.191	3000	0.0072	2048pulse/rev	0.22
HL6B	HC-AQ0235BD		20	0.0637	0.191		0.0095		0.32
J001	HC-KFS053	200	50	0.16	0.48		0.053	Absolute/ Incremental 17bits	0.4
J002	HC-KFS13		100	0.32	0.95		0.084		0.53
J003	HC-KFS23		200	0.64	1.9		0.42		0.99
J004	HC-KFS43		400	1.3	3.8		0.67		1.45
J005	HC-KFS73		750	2.4	7.2		1.51		3.0
J006	HC-KFS053B		50	0.16	0.48		0.056		0.75
J007	HC-KFS13B		100	0.32	0.95		0.087		0.89
J008	HC-KFS23B		200	0.64	1.9		0.47		1.6
J009	HC-KFS43B	400	1.3	3.8	0.72	2.1			
J010	HC-KFS73B	750	2.4	7.2	1.635	4.0			

Motor mounting dimension

unit : mm

Motor code	$\square W \times L_M$	LR	LE	d	D	P	M
HL6	28 × 61	16	2.5	6	20	33	$\phi 2.9$
HL6B	28 × 88	16	2.5	6	20	33	$\phi 2.9$
J001	40 × 81.5	25	2.5	8	30	46	$\phi 4.5$
J002	40 × 96.5	25	2.5	8	30	46	$\phi 4.5$
J003	60 × 99.5	30	3	14	50	70	$\phi 5.8$
J004	60 × 124.5	30	3	14	50	70	$\phi 5.8$
J005	80 × 142	40	3	19	70	90	$\phi 6.6$
J006	40 × 109.5	25	2.5	8	30	46	$\phi 4.5$
J007	40 × 124.5	25	2.5	8	30	46	$\phi 4.5$
J008	60 × 131.5	30	3	14	50	70	$\phi 5.8$
J009	60 × 156.5	30	3	14	50	70	$\phi 5.8$
J010	80 × 177.5	40	3	19	70	90	$\phi 6.6$

Specification of Mitsubishi AC servo driver (RoHS compliant)

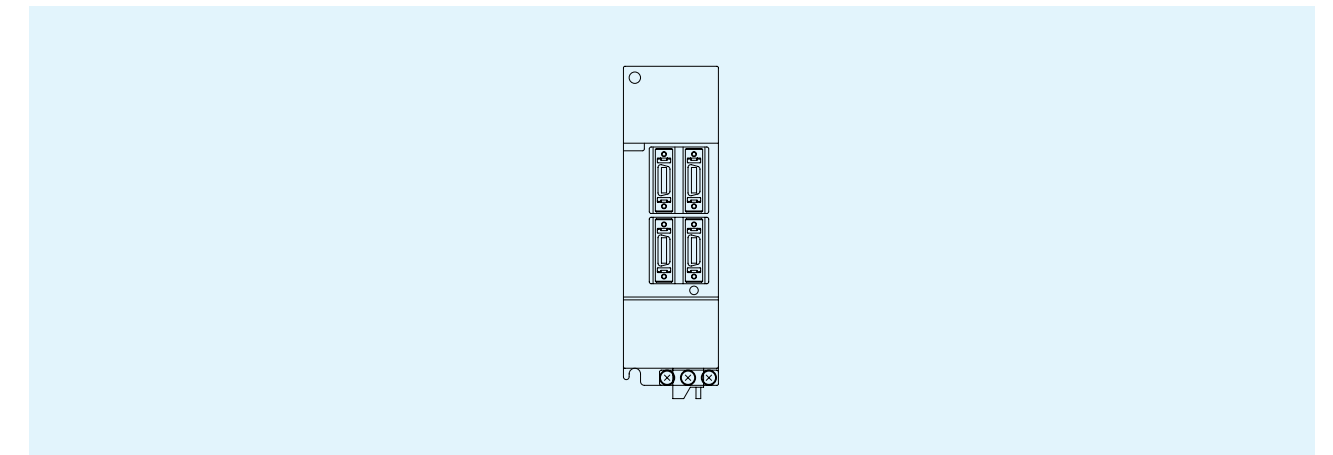

Driver specifications

Model number of driver	MR-J2-03A5	MR-J2S-10A		MR-J2S-20A	MR-J2S-40A	MR-J2S-70A
Applicable motor code	HL6, HL6B	J001, J006	J002, J007	J003, J008	J004, J009	J005, J010
Rated output	20W	50W	100W	200W	400W	750W
Feed back	Incremental encoder	Absolute/Incremental 17bits				
Command Input pulse	Selection one from symbol with pulse line, CCW or CW with pulse line, two phase pulse with 90-degree difference (A-phases or B-phases)					
Type of Command Input pulse	Line driver or Open collector					
Main power supply voltage	DC21.6~30V	Triphase AC200~230V, 50/60Hz or Single phase AC230V, 50/60Hz				
Control circuit supply voltage	DC24V±10%	Single phase AC200~230V, 50/60Hz				
Rated output current A	1.6	0.83	0.71	1.1	2.3	5.8
Maximum consumption current A	4.8	2.5	2.2	3.4	6.9	18.6
Ambient temperature in operation	0~55°C (Keep Freeze free)					
Ambient temperature in storage	-20~65°C (Keep Freeze free)					
Ambient temperature in operation and storage	90%RH or less (Keep dew drop free)					
Mass kg	0.2	0.7	0.7	1.1	1.7	

Specification of Oriental Stepper motor (RoHS compliant)

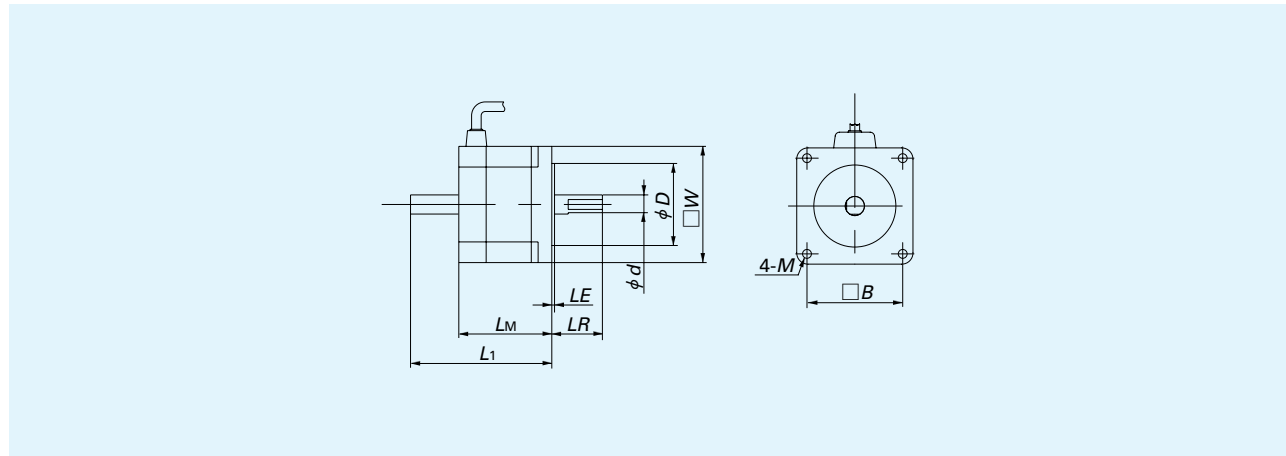

Motor specifications

Motor code	Motor Model number	Step angle	Maximum holding torque N · m	Current A-phase	Rotor inertia J_M kg · m ²	Mass kg
V004	PK523PA	0.72	0.048	0.35	9.0×10^{-7}	0.11
V005	PK545AW	0.72	0.24	0.75	0.68×10^{-5}	0.4
V006	PK545AWM	0.72	0.24	0.75	0.83×10^{-5}	0.52
V011	PK569AE	0.72	1.66	1.4	5.6×10^{-5}	1.3
V012	PK569AEM	0.72	1.66	1.4	7.2×10^{-5}	1.6
V015	PK599AE	0.72	4.1	1.4	27×10^{-5}	2.8
V016	PK599AEM	0.72	4.1	1.4	37.7×10^{-5}	3.5

Motor mounting dimensions

unit : mm

Motor code	$\square W \times L_M$	L_1	LR	LE	d	D	B	M
V004	28 × 32	—	15	1.5	5	22	23	M2.5 depth 2.5
V005	42 × 47	—	20	2	5	22	31	M3 depth 4.5
V006	42 × 77	—	20	2	5	22	31	M3 depth 4.5
V011	60 × 89	—	24	1.5	8	36	50	ϕ 4.5
V012	60 × 129	—	24	1.5	8	36	50	ϕ 4.5
V015	85 × 98	—	37	2	14	60	70	ϕ 6.5
V016	85 × 149	—	37	2	14	60	70	ϕ 6.5

Specification of Oriental stepper driver (RoHS compliant)

Model number of driver	CRD 5103P	RKD 507-A	RKD 507M-A	RKD 514L-A	RKD 514LM-A	RKD 514H-A	RKD 514HM-A	
Applicable motor code	V004	V005	V006	V011	V012	V015	V016	
Executing type	Micro step							
Input	CW/CCW signal, Pulse / Rotational direction signal							
Input type	Photo coupler input, input resistance 220Ω Input current 10~20mA							
Power supply	DC24V±10% 0.7A	Single phase 100-115V±15% 50/60Hz 1A		Single phase 100-115V±15% 50/60Hz 4.5A				
Ambient temperature in operation	0~40°C (Keep Freeze free)	0~50°C (Keep Freeze free)						
Ambient temperature in storage	85% or less (Keep dew drop free)							
Mass kg	0.04	0.4		0.85				



Torque characteristics of stepper motor

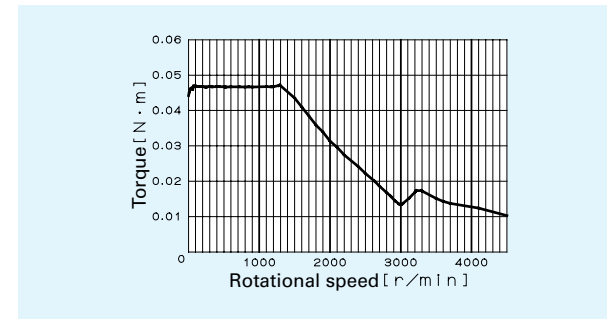

Motor code	Motor type	Driver type
V004	PK523PA	CRD5103P

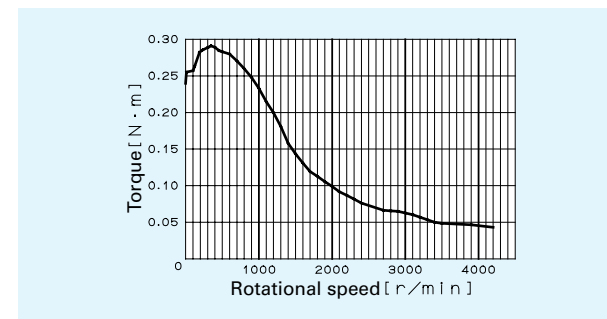

Motor code	Motor type	Driver type
V005	PK545AW	RKD507-A

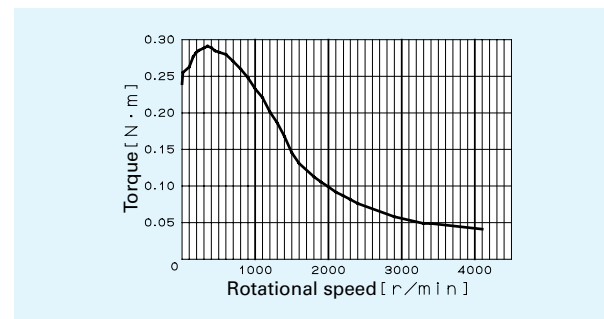

Motor code	Motor type	Driver type
V006	PK545AWM	RKD507M-A

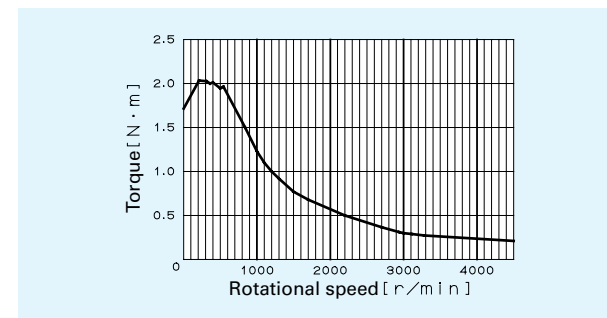

Motor code	Motor type	Driver type
V011	PK569AE	RKD514L-A

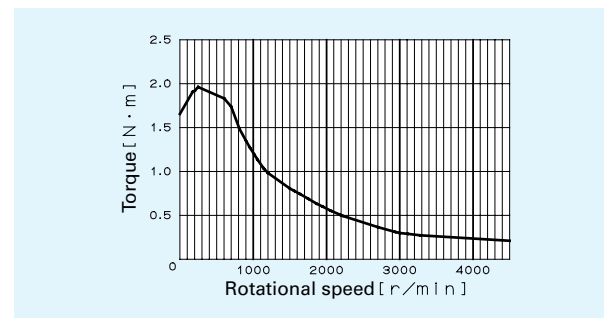

Motor code	Motor type	Driver type
V012	PK569AEM	RKD514LM-A

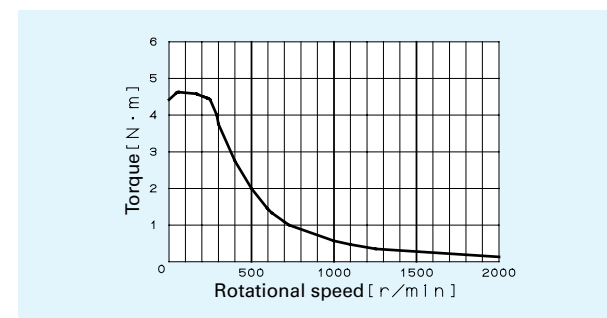

Motor code	Motor type	Driver type
V015	PK599AE	RKD514H-A

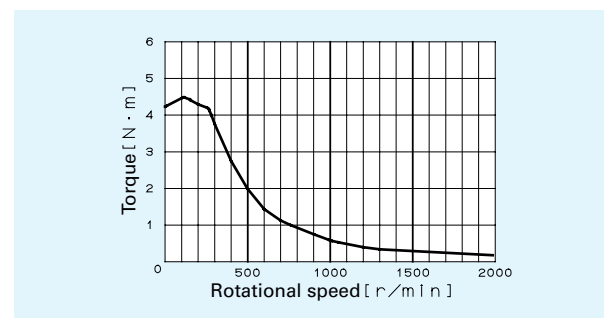

Motor code	Motor type	Driver type
V016	PK599AEM	RKD514HM-A

Table 29 Specification of wiring and connector for Oriental stepper motor except motor code V004

Din No.	Color of lead wire	Connector (by Taiko Electronics AMP Co., Ltd)		
		Body side	Other side	
Without brake	1	Blue	Plug housing 172170-1	
	2	N/A		
	3	Red		
	4	N/A		
	5	Orange		
	6	N/A		
	7	Green		
	8	N/A		
	9	Black		
	10	N/A		
	11	N/A		
	12	N/A		
With brake	1	Blue	Cap housing 172162-1	
	2	N/A		
	3	Red		
	4	N/A		
	5	Orange		
	6	N/A		
	7	Green		
	8	N/A		
	9	Black		
	10	N/A		
	11	Red/White (Brake input +)		Contactor 170364-1
	12	Black/White (Brake input -)		

Remarks 1 : Connector shall be prepared by customer.
2 : Connector for V004 motor code is included with motor.

System configuration

Each motor manufacture makes matching electrical components for their AC servo and stepper motors. By using their corresponding components you will attain a well-balanced system. Table 30 shows system configurations with AC servo motor and Table 31 shows system configurations with stepper motor. Table 32 shows system configurations with  Controller.

●System configuration of the table with AC servo motor (configuration with a driver and a programmable controller)

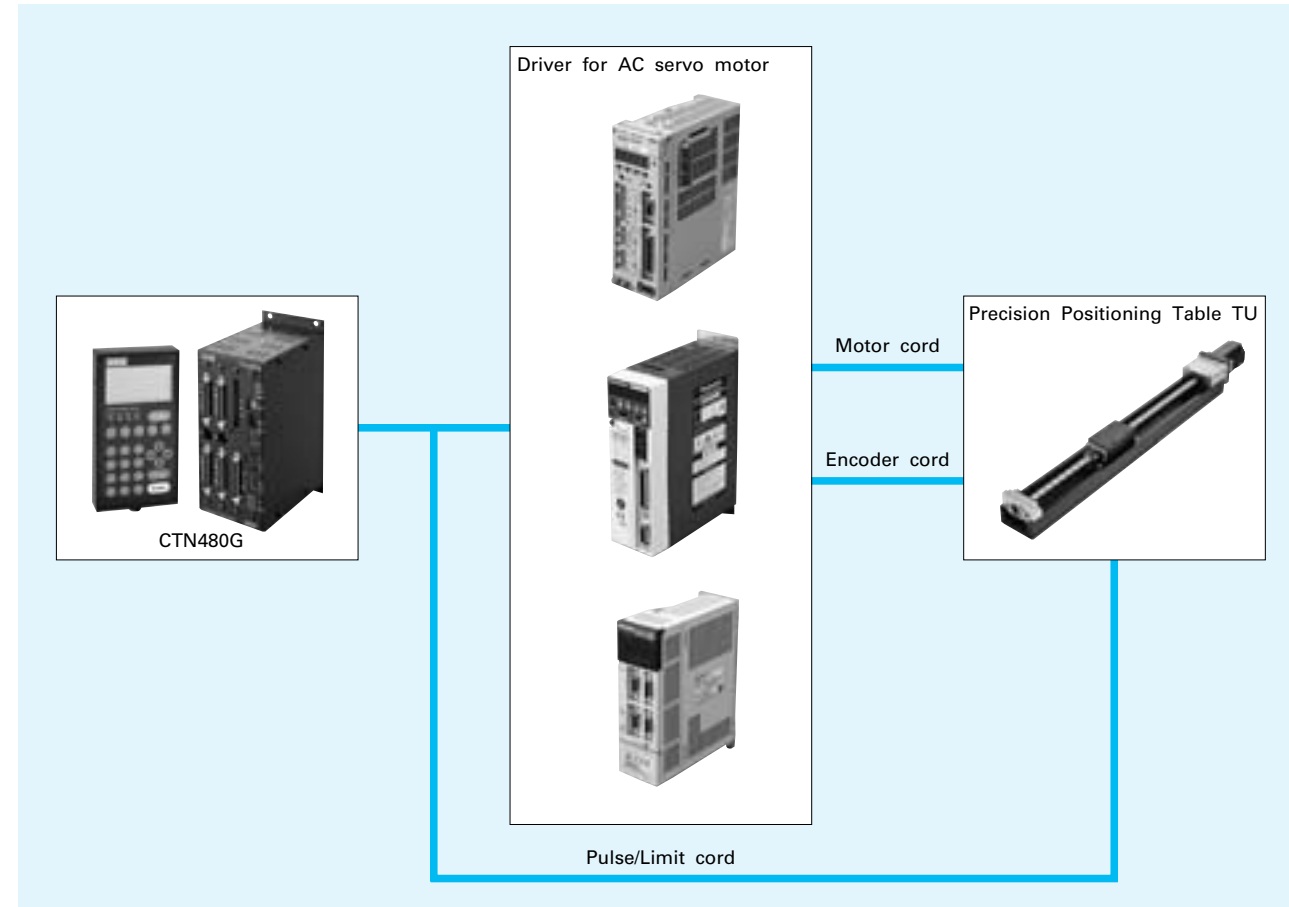

●System configuration of the table with stepper motor

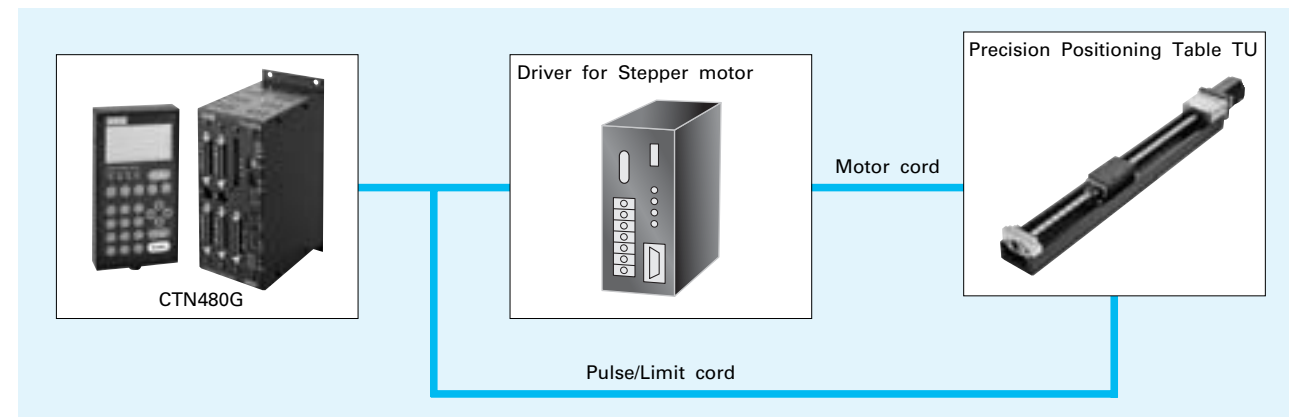

Table 30 Combination of Driver, Motor cord and Encoder cord for AC servo motor

Motor brand	Motor code	Driver	Motor cord	Encoder cord		
Yaskawa Electric	AL6	SGDF-A2CP	TAE20J6-AM□□ (TAE20J5-AM□□) Max. length : 5m	TAE20K0-EC□□ (TAE20J9-EC□□) Max. length : 5m		
			AL6B	TAE20J8-AMB□□ (TAE20J7-AMB□□) Max. length : 5m	TAE20K0-EC□□ (TAE20J9-EC□□) Max. length : 5m	
	Y027		SGDH-A5AE-E	TAE20G2-AM□□ (TAE20G1-AM□□)	TAE20G6-EC□□ (TAE20G5-EC□□)	
	Y028		SGDH-01AE-E			
	Y029		SGDH-02AE-E			
	Y030		SGDH-04AE-E			
	Y031		SGDH-08AE-E			
	Y032		SGDH-A5AE-E			
	Y033		SGDH-01AE-E	TAE20G4-AMB□□ (TAE20G3-AMB□□)	TAE20H2-EC□□ (TAE20H1-EC□□)	
	Y034		SGDH-02AE-E			
	Y035		SGDH-04AE-E			
	Y036		SGDH-08AE-E			
	Panasonic		P001	MSDA5A5A1A	TAE20G8-AM□□ (TAE20G7-AM□□)	TAE20H2-EC□□ (TAE20H1-EC□□)
			P002	MSDA015A1A		
			P003	MSDA023A1A		
			P004	MSDA043A1A		
P005		MSDA083A1A				
P006		MSDA5A5A1A	TAE20H0-AMB□□ (TAE20G9-AMB□□)			
P007		MSDA015A1A				
P008		MSDA023A1A				
P009		MSDA043A1A				
P010		MSDA083A1A				
Mitsubishi Electric	HL6	MR-J2-03A5	TAE20K2-AME□□ (TAE20K1-AME□□)	TAE20H8-EC□□ (TAE20H7-EC□□)		
	HL6B		TAE20K4-AMBE□□ (TAE20K3-AMBE□□)			
	J001	MR-J2S-10A	TAE20H4-AM□□ (TAE20H3-AM□□)			
	J002	MR-J2S-20A				
	J003	MR-J2S-40A				
	J004	MR-J2S-70A				
	J005	MR-J2S-70A	TAE20H6-AMB□□ (TAE20H5-AMB□□)			
	J006	MR-J2S-10A				
	J007	MR-J2S-10A				
	J008	MR-J2S-20A				
J009	MR-J2S-40A					
J010	MR-J2S-70A					

Remarks 1 : The cords in () have high bending resistance.
 2 : The length of cord can be specified by □□ in the end of supplemental code, Selectable length is up to 20m in increments of 1m. The length under 10m is also selected by two digits.



Programmable controller

Table 31 Combination of Driver, and Motor cord for Stepper motor

Motor code	Driver		Programmable Controller		
	Driver model number	Motor code	Controller model number	Teaching box	Pulse/Limit cord
V004	CRD5103P	TAE20R6-SM□□ ⁽¹⁾ (TAE20R7-SN□□)	CTN480G	TAE10M5-TB	TAE10Q8-LD□□ ⁽²⁾ (TAE10Q9-LD□□)
V005	RKD507A	TAE20R8-SM□□ ⁽²⁾ (TAE20R9-SN□□)	CTN480G	TAE10M5-TB	TAE10S3-LD□□ ⁽²⁾ (TAE10S4-LD□□)
V011	RKD514L-A				
V015	RKD514H-A	TAE20S1-SMB□□ ⁽²⁾ (TAE20S2-SNB□□)	CTN480G	TAE10M5-TB	TAE10S3-LD□□ ⁽²⁾ (TAE10S4-LD□□)
V006	RKD507M-A				
V012	RKD514LM-A				
V016	RKD514HM-A				

Note⁽¹⁾: Selectable length is up to 5m in increments of 1m.

⁽²⁾: Selectable length is up to 10m in increments of 1m.

⁽³⁾: Selectable length is up to 20m in increments of 1m. The length of pulse cord is 1.5m.

Remarks 1: The cords in () have high bending resistance.

2: The length of cord can be specified by □□ in the end of supplemental code by two digits.

Table 32 Combination of I/O Controller and Pulse/Limit cord

Controller	Teaching box	Motor brand	Motor cord	Pulse/Limit cord
CTN480G	TAE10M5-TB	Yaskawa Electric	AL○	TAE10P3-LD□□ (TAE10P4-LD□□)
			YO	TAE10M7-LD□□ (TAE10M8-LD□□)
		Panasonic	PO	TAE10M9-LD□□ (TAE10P0-LD□□)
			Mitsubishi Electric	HL○
		JO		TAE10P1-LD□□ (TAE10P2-LD□□)
		Oriental motor	V004	TAE20S1-LD□□ (TAE20S2-LD□□)
			VO	TAE10S3-LD□□ (TAE10S4-LD□□)

CTN480G (RoHS compliant)



- 1 Super high-performance type with up to 10,000 steps of program inputs available
- 2 High speed pulse output of up to 6 Mpps
- 3 Equipped with 4-axis linear interpolation and 2-axis circular interpolation functions as standard.
- 4 Accommodated with position compensation by using a linear encoder.
- 5 Enabled with save/transfer of programs with CompactFlash®
- 6 Easy configuration of a system without using a sequencer by built-in I/O sequence function, timer, counter, and calculation function
- 7 Enabled with edition, controller operation or direct execution of data by using a personal computer, as equipped with the USB interface as standard.
- 8 No need of return to origin due to accommodation with the absolute encoder
- 9 Enabled with simultaneous run/stop of arbitrary axes through the synchronization control function.
- 10 Enabled with simultaneous execution of up to 5 programs due to the multi-task function.
- 11 Enabled with precise positioning accuracy compensation through input of the positioning compensation data in advance.
- 12 Easy wiring to a driver due to the axis-dedicated input/output function
- 13 Enabled with connection of up to 4 controllers (16-axis control) due to link connection.

Table 33 Function/performance

Item		Model	CTN480G
Command pulse output specification	No. of controlled axes		4 axes (simultaneous execution possible)
	Max. command value		±2147483648 pulses (32-bit length with codes)
	Max. output frequency		6 Mpps
	Acceleration/deceleration time		0 - 65.533 sec (linear/cycloid/S acceleration/deceleration)
Program specification	Output method		CW/CCW pulse; direction command/forward reverse pulse; 90° phase difference pulse
	Input method		Personal computer via MDI, teaching or USB
	Command input method		Absolute or incremental command
Input/output specification	Program capacity		10,000 steps
	Function		Jump; call; repeat; four arithmetic operations; speed setting; acceleration/deceleration setting; timer control; I/O control; input condition branching; various edition functions (preparation, erasing, deletion, insert, copy, etc.)
	Input	No. of input points	
Control input			Start; stop; emergency stop; forward/reverse manual run; return to origin; present position resetting; interrupt; positioning completion; driver alarm input, etc. (selectively assigned with parameters by using the universal input)
Input method			Photo-coupler input (accommodated with no-voltage contacts or open collector)
Output	No. of output points		Universal output: 20 points Up to 80 points possible by the add-in I/O units
	Control output		Auto run in progress; limit sensor detection; emergency stop; pulse output in progress; return-to-origin completion; servo turn-on; driver alarm resetting; proportional control; deviation counter clear (selectively assigned with parameters by using the universal output)
	Output method		Open collector output (max. 30 VDC, 100 mA)
Input/output power supply			For I/O: 24 VDC, 4 A For the limit: 24 VDC, 100 mA
Other primary functions			USB (data read, write, direct execution, etc.); save/transfer of the program by the CompactFlash®; position compensation by the linear scale; backlash compensation; software limit; LS logic compensation; check functions (trace, I/O, LS, stop condition, etc.); 4-axis linear interpolation; 2-axis circular interpolation

Table 34 General specifications

Item	Model	CTN480G
Power supply voltage		24 VDC, $\pm 10\%$
Max. consumption current		4.5A
Ambient temperature		0 to 50°C During storage: -10 to 60°C
Ambient humidity		20 to 85% (no condensation)
Measure against power outage		Flash memory
Mass (as reference)		1.2 kg

Table 35 List of CTN480G accessories

Type	Model	Remarks
I/O connector	1015D-3000PE (Plug)	Sumitomo 3M
	1035D-52Y0-008 (Cover)	
Power connector	XW4B-0381-HI	OMRON Corp.
	4832.1310 (2 pcs)	Schutter AG
Link connector	CFS1/4C101J (Terminating resistance)	KOA Corp.
DIN rail fittings	DRT-1	Takachi Electric Industrial Co., Ltd.

Table 36 Optional products

Type	Model	Remarks
Teaching box	TAE10M5-TB	
I/O add-in unit	TAE10M6-KB	Expanded by 40 input points and 40 output points (up to 2 units added)

Remarks 1 : Cable used for USB communications shall be prepared by customer. The connector fitted on the cable is to be of A-A type (see Fig.6).

2 : CompactFlash® (compliant with Type 1) shall be prepared by customer (see Fig. 7).

3 : CompactFlash is a registered trademark of SanDisk Corporation in the US.

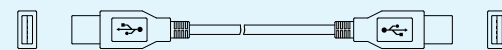
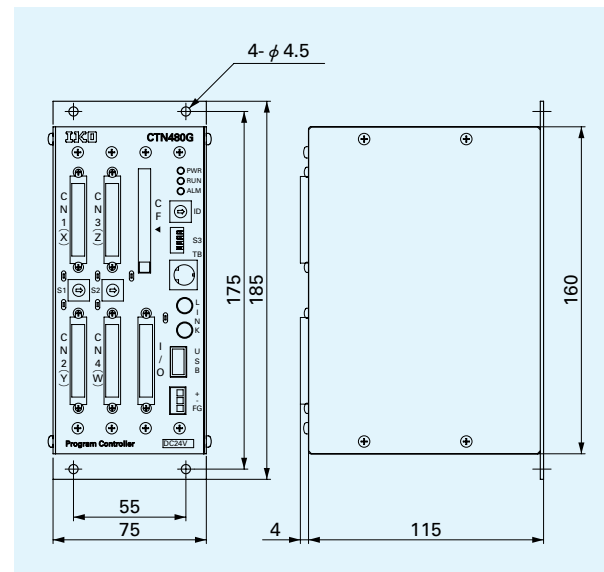

Fig. 6 USB cable (connector : A-A type)

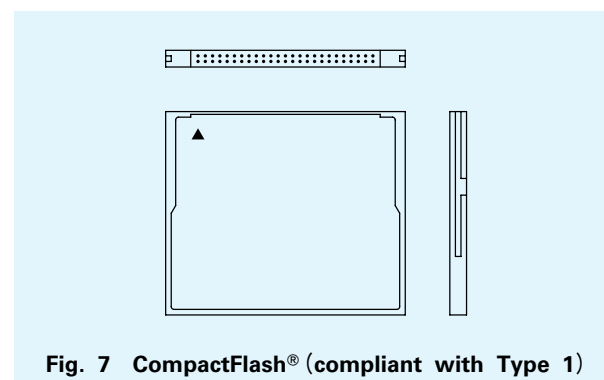

Fig. 7 CompactFlash® (compliant with Type 1)

Examination of operation pattern

■ Calculation of positioning time

The positioning time can be calculated by the following formula.

For an application requiring high-accuracy positioning, it is necessary to consider of setting time from completion of command pulse input till a complete stop of the table at the positioning point and periodic damping time of the machine in addition to the constant-speed travel time and acceleration/deceleration time.

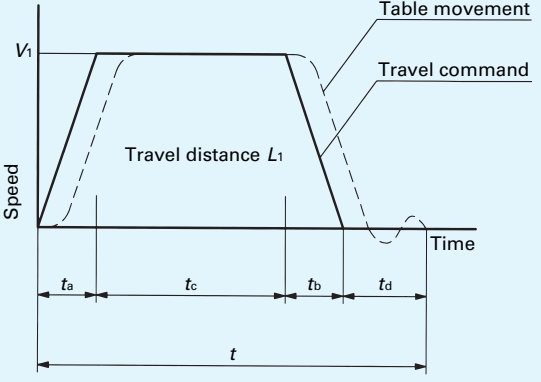
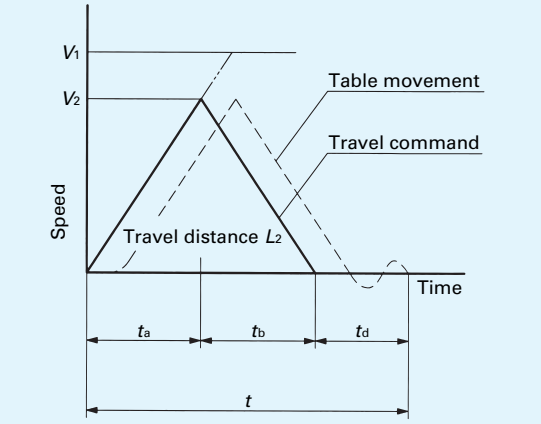
<p>Long distance positioning</p> <p>The long distance in this case means the distance that allows enough constant-speed travel time even if the acceleration/deceleration time is taken into consideration.</p> $t = \frac{L_1}{V_1} + \frac{t_a + t_b}{2} + t_d$ <p>where, t : Positioning time s t_a, t_b : Acceleration/deceleration time s t_c : Constant-speed travel time s t_d : Setting time s L_1 : Travel distance mm V_1 : Travel speed (set speed) mm/s</p>	
<p>Short-distance positioning</p> <p>The short distance in this case means the distance without constant-speed travel time in which deceleration is performed before a start of constant-speed travel.</p> $t = \frac{L_2}{V_2} + \frac{t_a + t_b}{2} + t_d$ <p>where, t : Positioning time s t_a, t_b : Acceleration/deceleration time s t_d : Setting time s L_2 : Travel distance mm V_1 : Set speed mm/s V_2 : Travel speed mm/s</p>	

■ Calculation of critical acceleration time

The torque required for Precision Positioning Table TU to be driven is maximized at acceleration. The torque required for this acceleration is limited by the motor output torque. The critical acceleration time for Precision Positioning Table TU operating in a horizontal direction can be calculated by the following formula.

<p>For ball screw drive or timing belt drive</p> <ul style="list-style-type: none"> • Load torque T_L $T_L = T_0 + \mu Wg \cdot \frac{\ell}{2\pi\eta} \text{ [N} \cdot \text{m]} \dots \text{Ball screw drive}$ • Acceleration torque T_a $T_a = (J_T + J_M + J_C + J_L) \cdot \frac{2\pi N}{60 t_a} \text{ [N} \cdot \text{m]}$ $J_L = W \cdot \left(\frac{\ell}{2\pi}\right)^2 \text{ [kg} \cdot \text{m}^2] \dots \text{Ball screw drive}$ • Torque required for acceleration T_P $T_P = T_L + T_a \text{ [N} \cdot \text{m]} \quad (T_P \times k < T_M)$ • Critical acceleration time t_a $t_a = (J_T + J_M + J_C + J_L) \cdot \frac{2\pi N}{60} \cdot \frac{k}{T_M - T_L} \text{ [s]}$ 	<p>T_0 : Starting torque N · m μ : Coefficient of friction of the rolling guides (0.01) W : Load mass kg ℓ : Ball screw lead m η : Efficiency 0.9 J_T : Table inertia kg · m² J_M : Motor inertia kg · m² J_C : Coupling inertia (Approx. 0.5 × 10⁻⁵ kg · m²) J_L : Load mass inertia kg · m² N : Motor rotation speed r/min t_a : Acceleration time s g : Gravitational acceleration (9.8m/s²) T_M : Motor output torque N · m <ul style="list-style-type: none"> • For T_M of the stepping motor, read the output torque at motor rotation speed N shown in Figure 2 Torque characteristic diagram. • For T_M of the AC servo motor, double or treble the rated torque. k : Safety factor (AC servo motor : 1.3) (Stepping motor : 1.5 to 2)</p>
--	---

■ Calculation of effective torque

When Precision Positioning Table TU is driven, a large torque is required at acceleration and deceleration. Accordingly, the effective torque may be larger than the rated torque of the motor depending on the operation ratio of operation pattern in the case of the AC servo motor. If the operation is continued in this status, the motor may heat up, resulting in seizure. For this reason, make sure that the effective torque is smaller than the rated torque. The effective torque based on the operation pattern of the table can be calculated by the following expression.

When the rated torque of the motor is larger than the effective torque, the motor can be operated continuously according to this operation pattern.

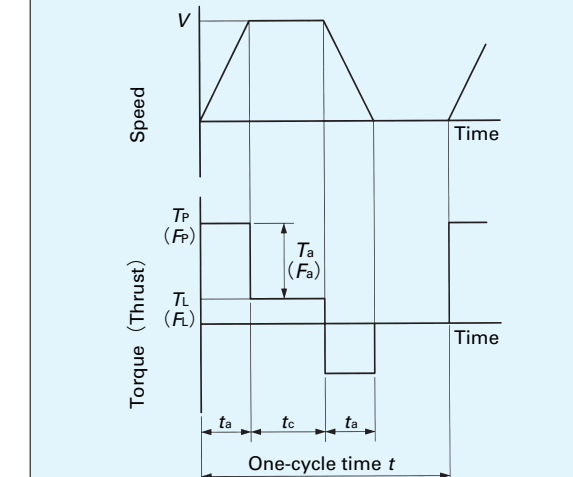
<p>When using the AC servo motor</p> <ul style="list-style-type: none"> • Effective torque T_{rms} $T_{rms} = \sqrt{\frac{T_P^2 \times t_a + (T_P - 2 \times T_L)^2 \times t_a + T_L^2 \times t_c}{t}} \text{ [N} \cdot \text{m]}$ 	
--	---

Installation of TU

Example of operation pattern examination

When using the AC servo motor

Operating conditions

Mounting direction	Use in horizontal form	
Load mass	W	30kg
Stroke length	L	300mm
Travel speed (set speed)	V	300mm/s
Acceleration/deceleration time	t_a	0.2s
Constant-speed travel time	t_c	0.8s
One-cycle time	t	2.0s

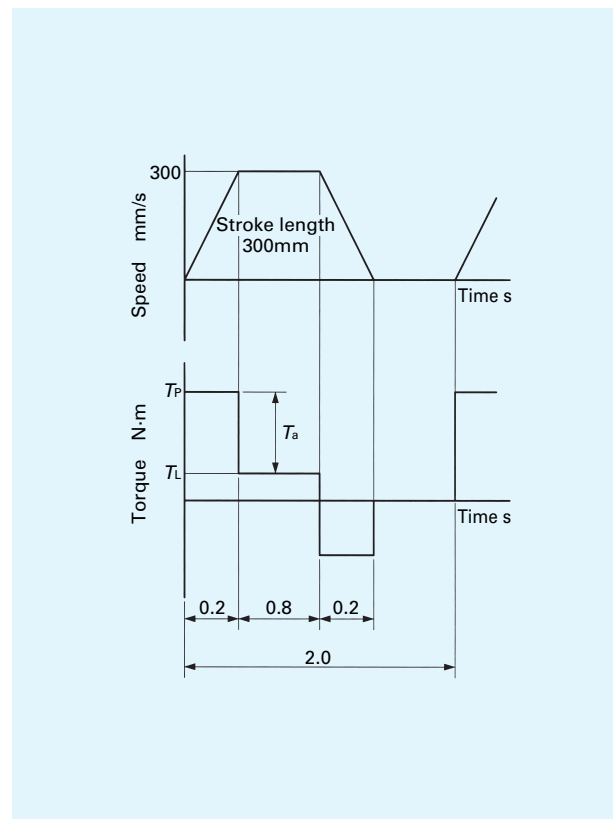

Temporary selection of Positioning Table

TU60S49A/Y028G10S03 is temporarily selected.

Basic specifications		
Ball screw lead	ℓ	10mm
Stroke length		300mm
Maximum speed		500mm/s
Starting torque	T_0	0.12N·m
Table inertia	J_T	$0.93 \times 10^{-5} \text{kg} \cdot \text{m}^2$
AC servo motor that is used		SGM-01B512
Rated torque		0.318N·m
Motor inertia	J_M	$0.0364 \times 10^{-4} \text{kg} \cdot \text{m}^2$

Calculation of the torque required for acceleration

• Load torque T_L

$$T_L = T_0 + \mu Wg \cdot \frac{\ell}{2\pi\eta}$$

$$= 0.12 + 0.01 \times 30 \times 9.8 \times \frac{0.01}{2 \times \pi \times 0.9}$$

$$\approx 0.13 \text{ [N} \cdot \text{m]}$$

• Acceleration torque T_a

$$J_L = W \cdot \left(\frac{\ell}{2\pi}\right)^2$$

$$= 30 \times \left(\frac{0.01}{2 \times \pi}\right)^2 \approx 7.60 \times 10^{-5} \text{ [kg} \cdot \text{m}^2]$$

$$N = V \times \frac{60}{\ell} = 0.3 \times \frac{60}{0.01} = 1800 \text{ [r/min]}$$

$$T_a = (J_T + J_M + J_C + J_L) \cdot \frac{2\pi N}{60 t_a}$$

$$= (0.93 + 0.4 + 0.5 + 7.60) \times 10^{-5} \times \frac{2 \times \pi \times 1800}{60 \times 0.2}$$

$$\approx 0.09 \text{ [N} \cdot \text{m]}$$

• Torque required for acceleration T_P

$$T_P = T_L + T_a = 0.13 + 0.09 = 0.22 \text{ [N} \cdot \text{m]}$$

Now, make sure that $T_P \times k$ (safety factor) is smaller than the motor output torque T_M . If this value is exceeded, examine the maximum speed and acceleration/deceleration time again. In the case of the operation pattern under examination, this value is smaller than the output torque T_M as shown below.

$$T_M = 0.318 \times 3 \approx 0.95 \text{ [N} \cdot \text{m]}$$

$$T_P = k = 0.22 \times 1.3 = 0.29 \text{ [N} \cdot \text{m]} < T_M$$

Examination of effective torque

• Effective torque T_{rms}

$$T_{rms} = \sqrt{\frac{T_P^2 \times t_a + (T_P - 2 \times T_L)^2 \times t_a + T_L^2 \times t_c}{t}}$$

$$= \sqrt{\frac{0.29^2 \times 0.2 + (0.29 - 2 \times 0.13)^2 \times 0.2 + 0.13^2 \times 0.8}{2.0}}$$

$$\approx 0.12 \text{ [N} \cdot \text{m]}$$

Because the rated torque of the motor is larger than the effective torque T_{rms} , it can be judged that the motor can be operated continuously according to the operation pattern that is examined.

Work accuracy of the mounting surface

The accuracy and performance of Precision Positioning Table TU are affected by the accuracy of the mounting surface of the mounting base (and the object being mounted on TU). Accordingly, it is necessary to consider of work accuracy of mounting surface according to the operating conditions including required kinematical performance and positioning accuracy.

The standard flatness of a mounting surface is 0.030 mm or less under the general operating conditions.

The trestle on which the table is installed receives large reaction force. So rigidity must be fully considered for the trestle.

Tightening torque of fixing screws

Table 37 shows the general tightening torque values for fixing Precision Positioning Table TU. If sudden acceleration or sudden deceleration is often applied or a moment is loaded, it is recommended to tighten screws with about 1.3 times the torque values shown in the table. If vibration or shock is not applied but high accuracy is required, we recommend using an adhesive as the screw anti-loosening agent after tightening screws with smaller torque values than those shown in the table.

Table 37 Tightening torque of screws

unit : N·m

Nominal size of screw	Female screw material	
	Iron	Aluminum alloy
		With helisert
M 3×0.5	1.7	Approx. 60% of the numeric value of iron
M 4×0.7	4.0	
M 5×0.8	7.9	
M 6×1	13.3	
M 8×1.25	32.0	
M10×1.5	62.7	Approx. 80% of the numeric value of iron

X-Y bracket

X-Y bracket can be used for IKO Precision Positioning Table TU to construct two axes tables in various combinations. X-Y bracket is made of light-weight aluminum alloy and can be assembled on a flange type table. Table 38 shows types of X-Y brackets. Specify the identification number shown in the table for ordering. Dimensions of each bracket are shown on Table 39.1 and 39.2.

Table 38 Combinations of two axes and types of X-Y brackets

Combinations with X-Y bracket			Combinations without X-Y bracket		
					
X axis	Y axis	Identification number of X-Y bracket	X axis	Y axis	Identification number of X-Y bracket
—	—	—	TU 25F	TU 25	Not required
—	—	—	TU 30F	TU 30	Not required
TU40F	TU40	TAE0412-BR	—	—	—
TU50F	TU40	TAE0413-BR	—	—	—
TU50F	TU50	TAE0414-BR	—	—	—
TU60F	TU50	TAE0415-BR	—	—	—
TU60F	TU60	TAE0409-BR	—	—	—
TU86F	TU60	TAE0410-BR	TU 86F	TU 60	Not required
TU86F	TU86	TAE0411-BR	TU 86F	TU 86	Not required
—	—	—	TU130F	TU100	Not required

Table 39.1 Dimensions of X-Y bracket



Identification number	W	W ₁	W ₂	W ₃	W ₄	H	H ₁	H ₂	H ₃	H ₄	H ₅	L	L ₁	L ₂	L ₃	L ₄	L ₅	M ₁	d ₁	d ₂	h ₁
TAE0412-BR	90	55	17.5	60	15	67	38	18	11	27	40	48	7	18	23	36	12	M3	4.5	8	4.5
TAE0413-BR	90	65	12.5	60	15	67	38	18	11	27	40	51	9	25	17	39	12	M3	4.5	8	4.5
TAE0414-BR	90	65	12.5	80	5	77	39.5	25	12.5	27	50	57	9	25	23	45	12	M4	4.5	8	4.5

Table 39.2 Dimensions of X-Y bracket

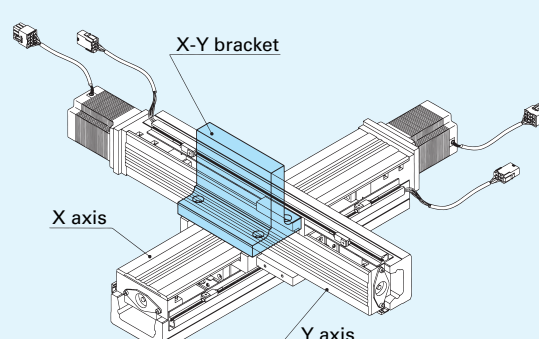
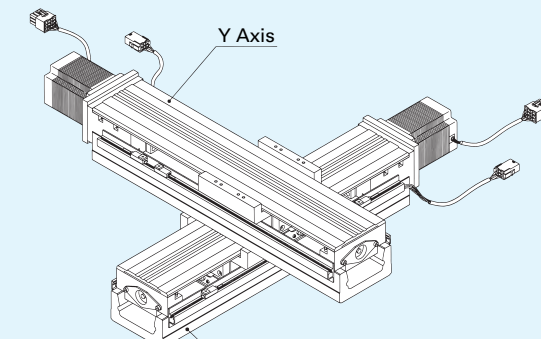
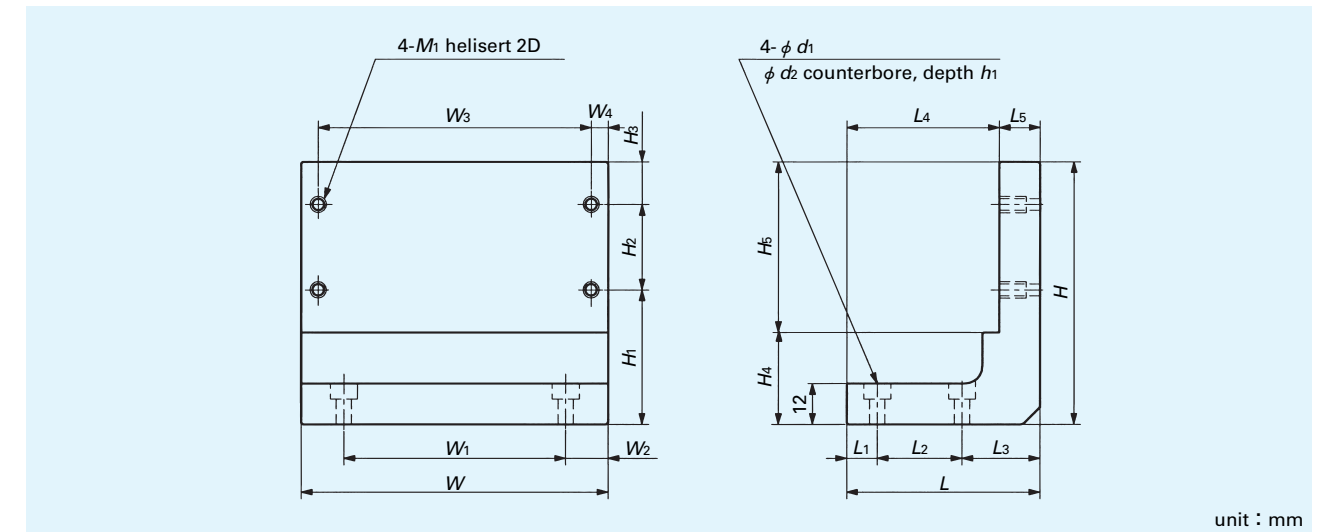
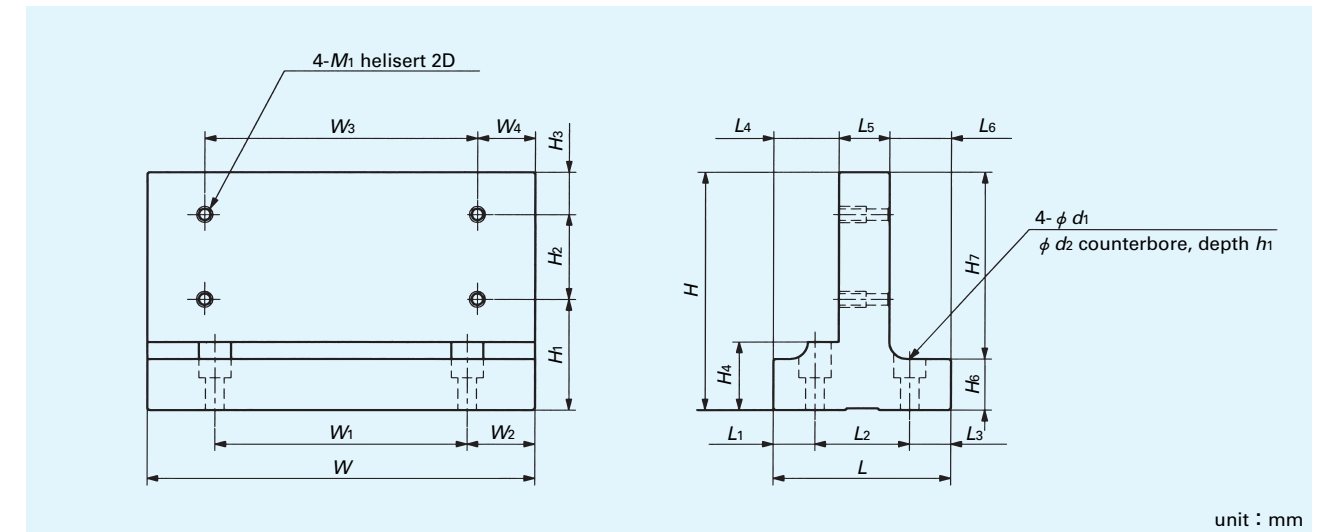

Identification number	W	W ₁	W ₂	W ₃	W ₄	H	H ₁	H ₂	H ₃	H ₄	H ₅	H ₆	H ₇	L	L ₁	L ₂	L ₃	L ₄	L ₅	L ₆	M ₁	d ₁	d ₂	h ₁
TAE0415-BR	114	74	20	80	17	70	32.5	25	12.5	20	15	55	52.4	12.2	28	12.2	19.2	15	18.2	18.2	M4	5.5	9.5	5.5
TAE0409-BR	114	74	20	100	7	80	36	28	16	20	15	65	52.4	12.2	28	12.2	19.2	15	18.2	18.2	M5	5.5	9.5	5.5
TAE0410-BR	114	100	7	100	7	80	36	28	16	20	15	65	70	12	46	12	25	20	25	25	M5	6.6	11	6.5
TAE0411-BR	114	100	7	100	7	106	40	46	20	20	15	91	73	13.5	46	13.5	26.5	20	26.5	26.5	M6	6.6	11	6.5

Lubrication

■Pre-packed grease and Grease fitting

A high quality lithium-soap base grease are pre-packed in Linear motion rolling guide and Ball screw of IKO Precision positioning table TU. Please refer pre-packed grease and grease fitting on Table 40.

When Miniature greaser or nozzle for grease gun is required, please consult with IKO.

Table 40 Grease and Grease fitting

Model	Pre-packed Grease	Grease fitting for Linear Way		Applicable supply nozzle
TU 25 TU 30	Multemp PS No.2 (KYODO YUSHI)	Oil hole (see Fig.8) d1=0.5	d2=1.2 d2=1.5	Miniature greaser MG10/MT2 (See Fig.10)
TU 40 TU 50 TU 60 TU 86 TU 100 TU 130	ALVANIA EP GREASE 2 (SHELL)	A-M4 (see Fig.9)		A-5120V (Straight nozzle) A-5240V (Straight nozzle) B-5120V (Angle nozzle) B-5240V (Angle nozzle)
		JIS A-M6F		Grease gun available on the market

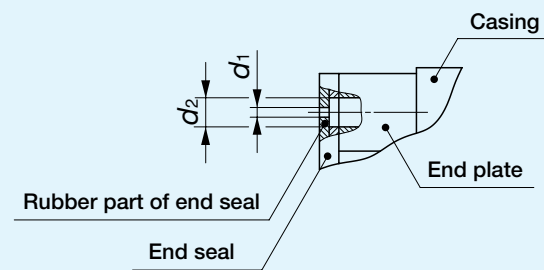

Fig. 8 Oil hole

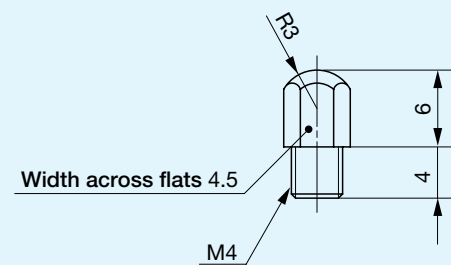

Fig. 9 A-M4 Grease nipple



Fig. 10 Miniature greaser MG10/MT2

Precaution on use

■Safety precautions

- Be sure to connect the grounding terminal to the ground (class 3 grounding). Otherwise, it is possible that an electric shock or fire could occur.
- Do not operate the equipment at any voltage other than the supply voltage indicated on the equipment. Otherwise, a fire or failure could occur.
- Do not touch electric devices with wet hands. Otherwise, an electric shock could occur.
- Do not bend, twist, pull, or heat the cord and do not put any heavy material on the cord. Otherwise, it is possible that an electric shock or fire could occur.
- During table operation, do not put fingers into the opening. Otherwise, an injury could occur.
- During table operation, do not touch the moving part. Otherwise, an injury may occur.
- Before removing the electric device cover, be sure to turn off the power supply and pull out the power plug. Otherwise, an electric shock could occur.
- After turning off the power supply, do not touch the terminal for 5 minutes. Otherwise, an electric shock could be caused by residual voltage.
- Before installing or removing the connecting terminal, be sure to turn off the power supply and pull out the power plug. Otherwise, an electric shock or fire could occur.

■Precautions on use

- Precision Positioning Table TU is a precision device. Giving an excessive load or shock to it will lower the accuracy and damage its components. Take extreme care when handling it.
- Make sure that there is no dust or harmful projection on the table mounting surface.
- Grease is applied to Linear Motion Rolling Guides and ball screws incorporated in Precision Positioning Table.
- Do not admit dust or foreign particles into Precision Positioning Table. If dust enters it, remove polluted grease completely and then apply clean grease again.
- Lubrication of Precision Positioning Table TU varies depending on the operating conditions. Generally, relubricate grease every 6 months. In the case of use involving long-distance reciprocating motion at all times, remove the old grease every 3 months, and then apply clean grease again.
- Precision Positioning Table TU is worked, assembled, and adjusted with high accuracy. Do not disassemble or modify this product.

■Duration and scope of warranty

The period of warranty for the precision positioning table and related electrical devices is set at one year after delivery.

If a failure occurs while the product is correctly being used and the failure is clearly attributable to its manufacture, the product will be repaired at no cost within the warranty period.

A warranty here means the guarantee of the precision positioning table itself as a single unit.

It shall be a fare-paying service if field service is required.

When the trouble is not obviously judged by our product deficiency as a result of our investigation, the customer shall be responsible for the repair cost. Secondary damage that occurs on the product breakdown or use is out of our warranty.

When disposing of the products, treat them as ordinary industrial waste.

Types and classification of IKO Precision Positioning Table

IKO Precision Positioning Table can be classified by the feed mechanisms, characteristics, and applications of the Slide Table as shown in the following table. Customers can select an optimum Positioning Table in the many series according to each application.

	Feed mechanism	Shape	Series	Single-axis specification model	Multi-axis specification model
Precision Positioning Table	Ball screw drive		Precision Positioning Table TU	TU	—
			Long Stroke Precision Positioning Table	TSL...M	—
			High Rigidity Precision Positioning Table	TSLH...M	CTLH...M
			Super Precision Positioning Table	TX	CTX
			Cleanroom Precision Positioning Table	TC	—
			Micro Precision Positioning Table	TM	—
			Compact Series	TS	CT
	Timing belt drive		High Speed Long Stroke Series	TSLB	—
	Linear motor drive		Linear Motor Table LT	LT, LT...M	—
			Nano Linear NT	NT, NT...V, NT...H	NT...XZ
Piezo motor drive		Piezo Stage	SP	—	
Precision Rotary Table	DD motor drive		Precision Rotary Table	RT	—
Precision Alignment Table	Ball screw drive		Precision Alignment Table	AT	—
Alignment Stage	Ball screw drive		Alignment Stage Module Type	—	SA...M
	Direct drive		Alignment Stage Direct Drive Type	SA...DE	—
Precision Elevating Table	Ball screw drive		Precision Elevating Table	TZ	—

Types of IKO Precision Positioning Table

Precision Positioning Table TU

- A high-rigidity U-shaped track rail is adopted.
- A desired table specification can be selected out of various types according to the application.



TU
CAT-57174

Long Stroke Precision Positioning Table TSL...M

- Standard type that has been used in various fields
- Stable characteristics obtained by using Linear Way in parallel form



TSL...M
CAT-57154

High Rigidity Precision Positioning Table TSLH...M/CTLH...M

- High reliability and high accuracy based on the use of strictly selected component parts.
- High rigidity and large load mass

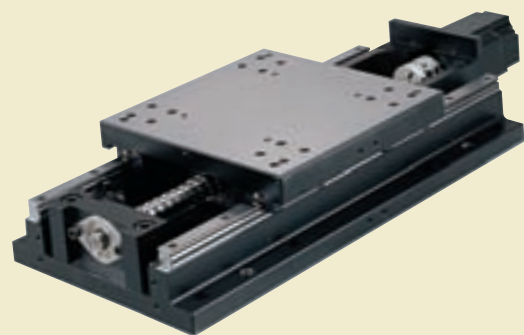

TSLH...M·CTLH...M
CAT-57157

Super Precision Positioning Table TX/CTX

- Stable running performance provided by using Linear Roller Way Super X
- High Precision under full-closed loop control

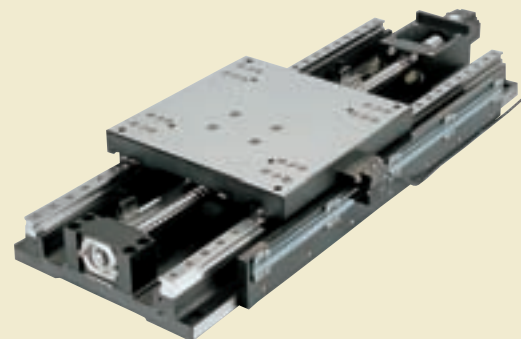

TX·CTX
CAT-57173

Types of IKO Precision Positioning Table

Cleanroom Precision Positioning Table TC

- Most suitable for applications requiring high cleanliness such as semiconductor or liquid crystal manufacturing systems
- Selectable from 3 types according to the application



TC...L
TC...U
TC...US
CAT-57123C

Micro Precision Positioning Table TM

- Very compact positioning table that is 20mm high (sectional) and 17mm wide driven by a ground ball screw.
- +/-0.5micron repeatability is achieved with 60 mm stroke length.



TM
CAT-57171

Compact Series TS/CT

- Low section height and compact structure
- High reliability and high precision provided by using Crossed Roller Way



TS·CT

High Speed Long Stroke Series TSLB

- High-speed type using a timing belt drive
- Stable and high running performance obtained by using Linear Way in parallel form



TSLB

Types of IKO Precision Positioning Table

Linear Motor Table LT

- High speed and high response provided by using a direct drive.
- Compact shape and large thrust
- Long stroke of up to 2760 mm

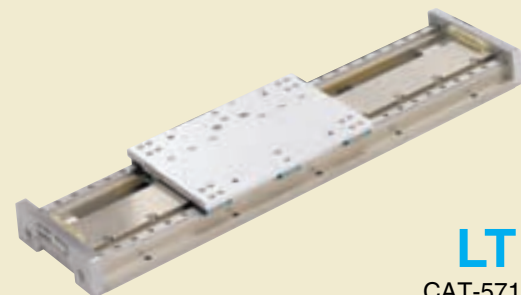

LT
CAT-57156

Linear Motor Table LT...M

- Various linear motor stages can be designed with module type compact linear motor.
- Twin module and parallel arrangement are available.



LT...M
CAT-57169

Nano Linear NT...V/NT

- High speed and high response provided by using a direct drive
- Very small and simple shape with a section height of 14 mm

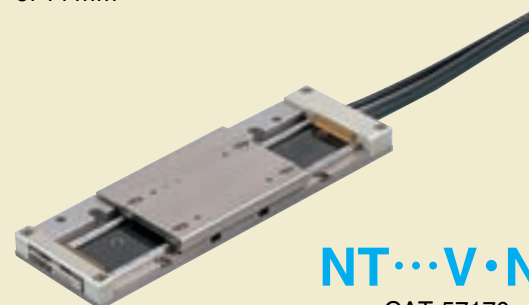

NT...V·NT
CAT-57170

Nano Linear NT...XZ

- Pick and place unit driven by a linear motor.
- Super slim type (18mm of thickness) achieves space-saving.

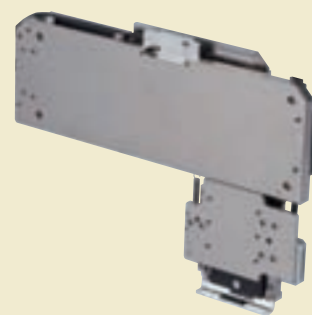

NT...XZ
CAT57170

Nano Linear NT...H

- Anti Creep Cage Crossed Roller Way achieve excellent positioning repeatability and straightness.
- Less than +/- 1% of speed stability at a speed of 10mm/s.



NT...H
CAT-57170

Piezo Stage SP

- 10 nano meter resolution in 10 micron stroke length.
- Rough and micromotion system can be built up.

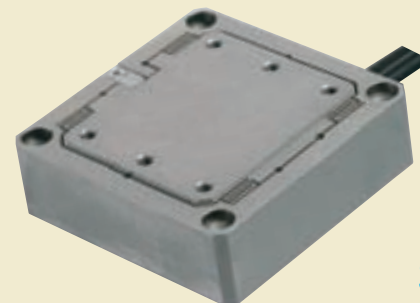

SP
CAT-57161

Types of IKO Precision Positioning Table

Precision Rotary Table RT

- High speed and high resolution turning positioning table
- High precision and high rigidity provided by using Crossed Roller Bearing



RT

Precision Alignment Table AT

- Precision angle correction can be performed by high accuracy positioning.
- High rigidity and compact shape achieved by using Crossed Roller Bearing.

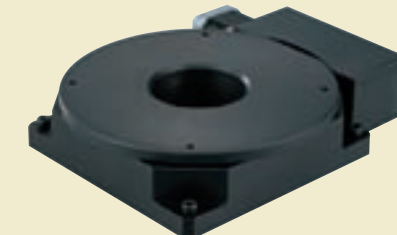

AT
CAT-57121

Alignment Stage Module Type SA...M

- XYθ stage that permits various operations
- Low section surface and compact shape achieved by using Alignment Module AM

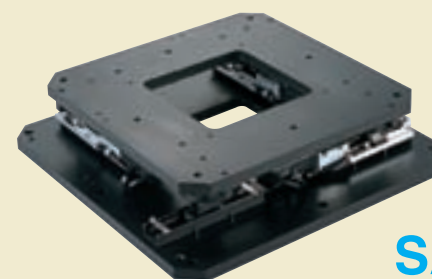

SA...M
CAT-57135

Alignment Module AM

- The stage can be freely designed according to the application.
- The height allowance can be controlled within $\pm 10 \mu\text{m}$.

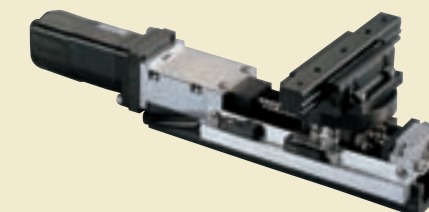

AM

Alignment Stage Direct Drive Type SA...DE

- The section height with a combination of 3 axes (X, Y and θ) is only 52 mm. (SA 65DE)
- High resolution of XY-axis: $0.1 \mu\text{m}$ and θ axis: 0.25 sec (SA 200DE)
- Maintenance free specification achieved by using C-Lube Linear Way

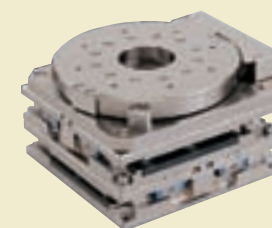

SA...DE
CAT-57158

Precision Elevating Table TZ

- Original wedge mechanism is adopted for elevating motion.
- Two types of wedge reduction ratio that can be selected according to the application



TZ
CAT-57172

Selection of IKO Precision Positioning Table

For selecting IKO Precision Positioning Table, the items closely related to the required conditions should be preponderantly considered.
The general selecting procedure is shown below.

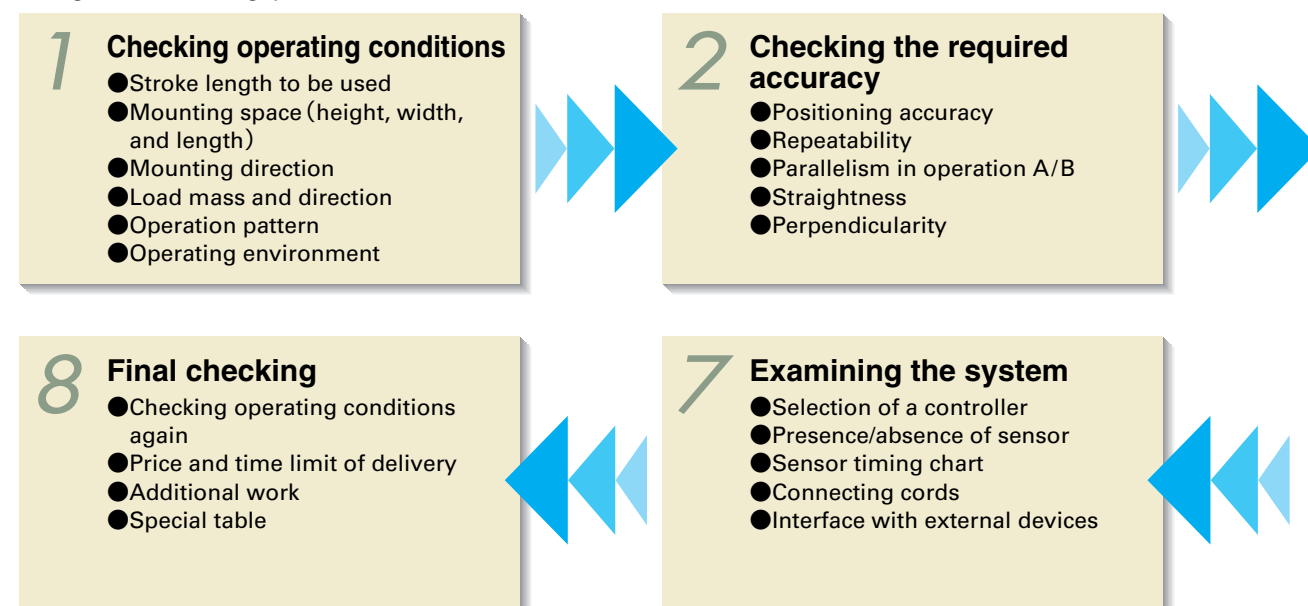

Selection of IKO Precision Positioning Table

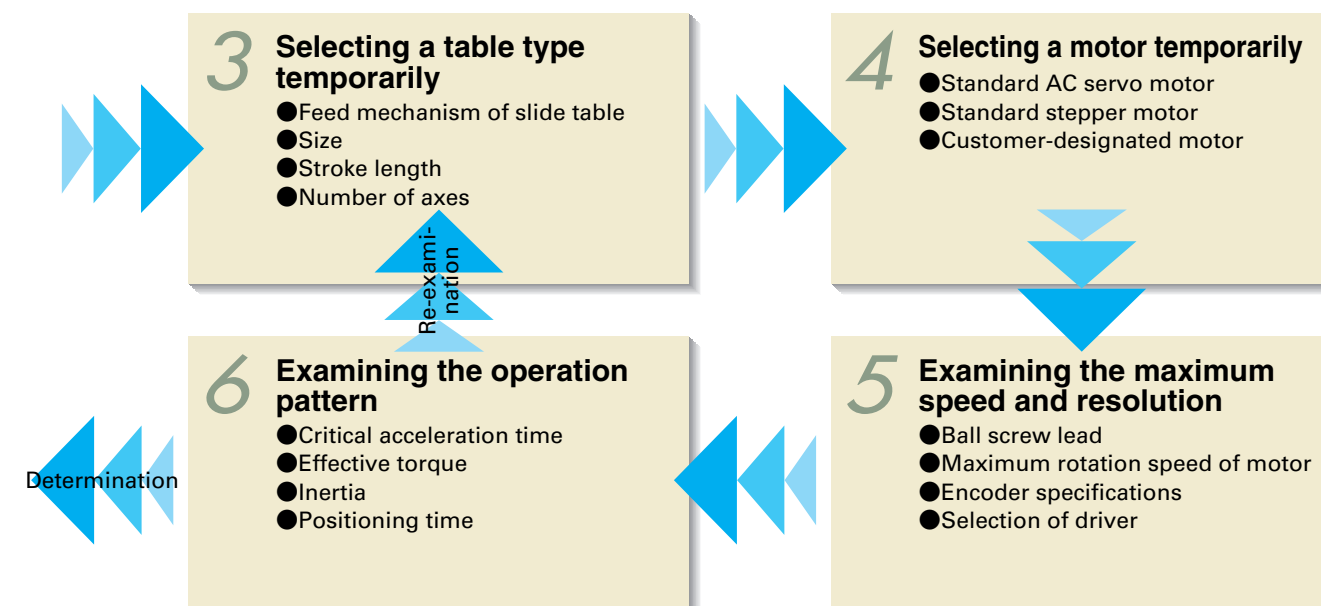

Characteristics of IKO Precision Positioning Table

Series	Model code	Stroke length mm	Positioning accuracy	Repeatability	High-speed performance
TU Series	TU	30 to 1400	○	○	○
Long Stroke Series	TSL...M	50 to 1000	○	○	○
High Rigidity Series	TSLH...M	100 to 800	◎	○	○
	CTLH...M	100 to 500	◎	○	○
High Precision Series	TX	100 to 800	◎	◎	○
	CTX	100 to 400	◎	◎	○
Clean Table Series	TC...U	100 to 750	○	○	○
	TC...L	140 to 880	○	○	○
	TC...US	30 to 600	○	○	○
Micro Precision Positioning Table	TM	10 to 60	◎	◎	△
Compact Series	TS	25 to 250	◎	○	△
	CT	15 to 250	◎	○	△
High Speed Long Stroke Series	TSLB	300 to 1200	△	△	◎
Linear Motor Table	LT...CD	200 to 1200	△	◎	◎
	LT...LD	240 to 2760	△	◎	◎
	LT...H	460 to 2710	△	◎	◎
Linear Motor Table Module	LT...M	120 to 300	△	◎	◎
Nano Linear	NT/NT...V	25, 65, 120	△	◎	◎
	NT...XZ	10 to 45	△	◎	◎
	NT...H	65	◎	◎	◎
Piezo Stage	SP	0.01	◎	◎	△

Rigidity	Feed mechanism	Driving motor	Sensor installation	Linear Motion Rolling Guides	Application
○	Ball screw	AC servo Stepper	Selection	U-shaped Track Rail Linear Way	Assembling machines, work machines, measuring instruments
○			Standard installation	C-Lube Linear Way 2 units in parallel	Assembling machines, work machines, measuring instruments
◎			Standard installation	C-Lube Linear Way 2 units in parallel	Precision work machines, precision measuring instruments, machine tools, assembling machines
◎			Standard installation	Linear Roller Way Super X 2 units in parallel	
△		AC servo Stepper	Selection	U-shaped Track Rail Linear Way	Semiconductor related systems, LCD related systems
△		AC servo	Standard installation	C-Lube Linear Way 2 units in parallel	
△		AC servo Stepper	Selection	U-shaped Track Rail Linear Way	
△			Selection	Micro Linear Way L 2 units in parallel	Precision measuring instruments, Precision assembling machine
△			Selection	Crossed Roller Way	Precision measuring instruments, probes, image processing units, exposure systems
△			Selection	Crossed Roller Way (Linear Way L)	
○	Timing belt	Stepper	Standard installation	Linear Way 2 units in parallel	High-speed transfer units, pallet changers
△	AC Linear servo motor	Standard installation	Standard installation	C-Lube Linear Way L 2 units in parallel	Semiconductor related systems, high-speed transfer units
△			Standard installation	C-Lube Linear Way 2 units in parallel	
△			Standard installation	C-Lube Linear Way L	Semiconductor related systems, LCD related systems
△		Standard installation	Micro Linear Way L 2 units in parallel	Semiconductor related systems, Medical related systems	
△		Standard installation	Micro Linear Way L 2 units in parallel	Precision assembling systems	
△		Standard installation	Crossed Roller Way	Precision measuring instruments, probes	
△		Piezo motor	Standard installation	—	Semiconductor-related systems, Optical equipments

Size of Precision Positioning Table

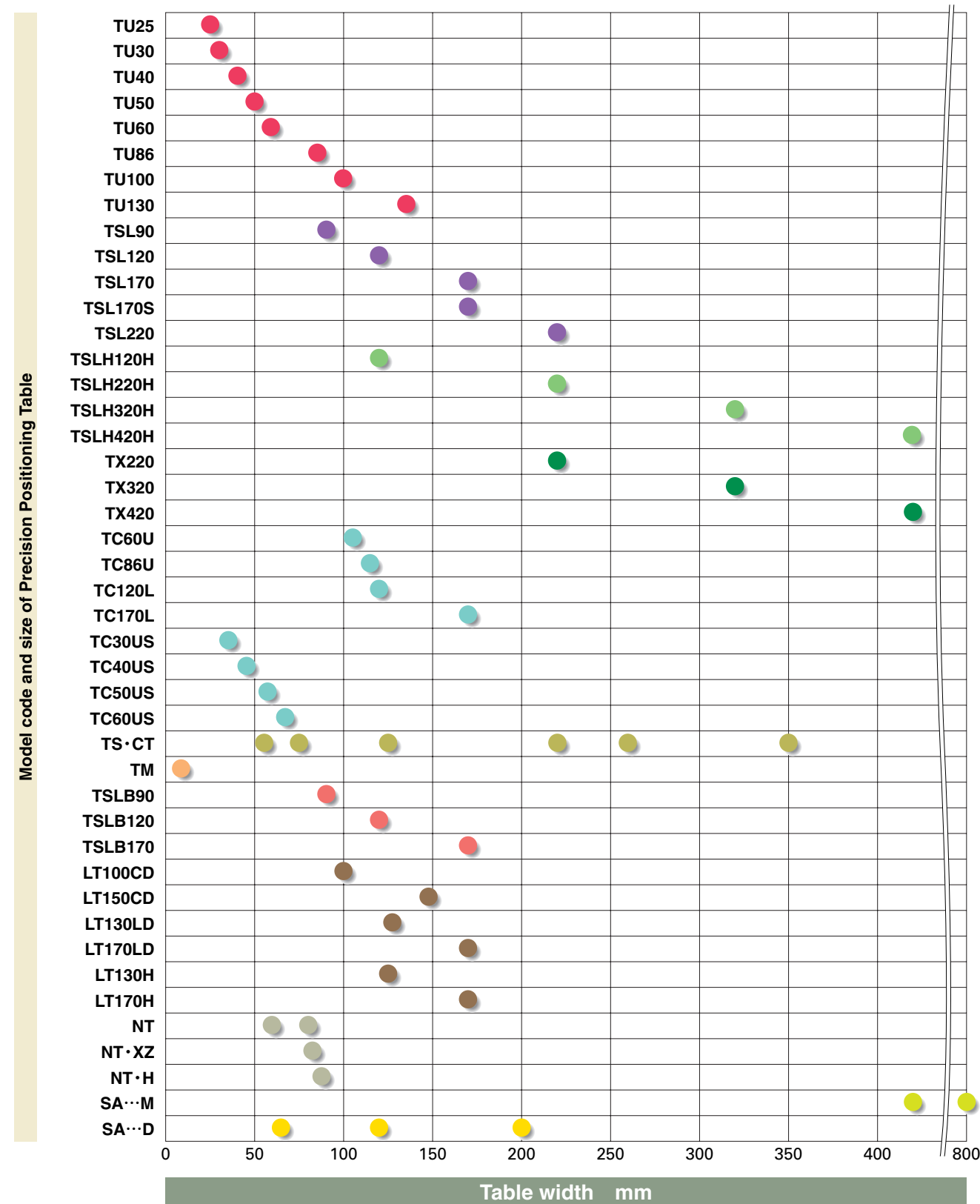

How to see the above graph

● The values shown in the graph are reference values. For details, refer to the separate catalogue of each model.

Stroke length of Precision Positioning Table

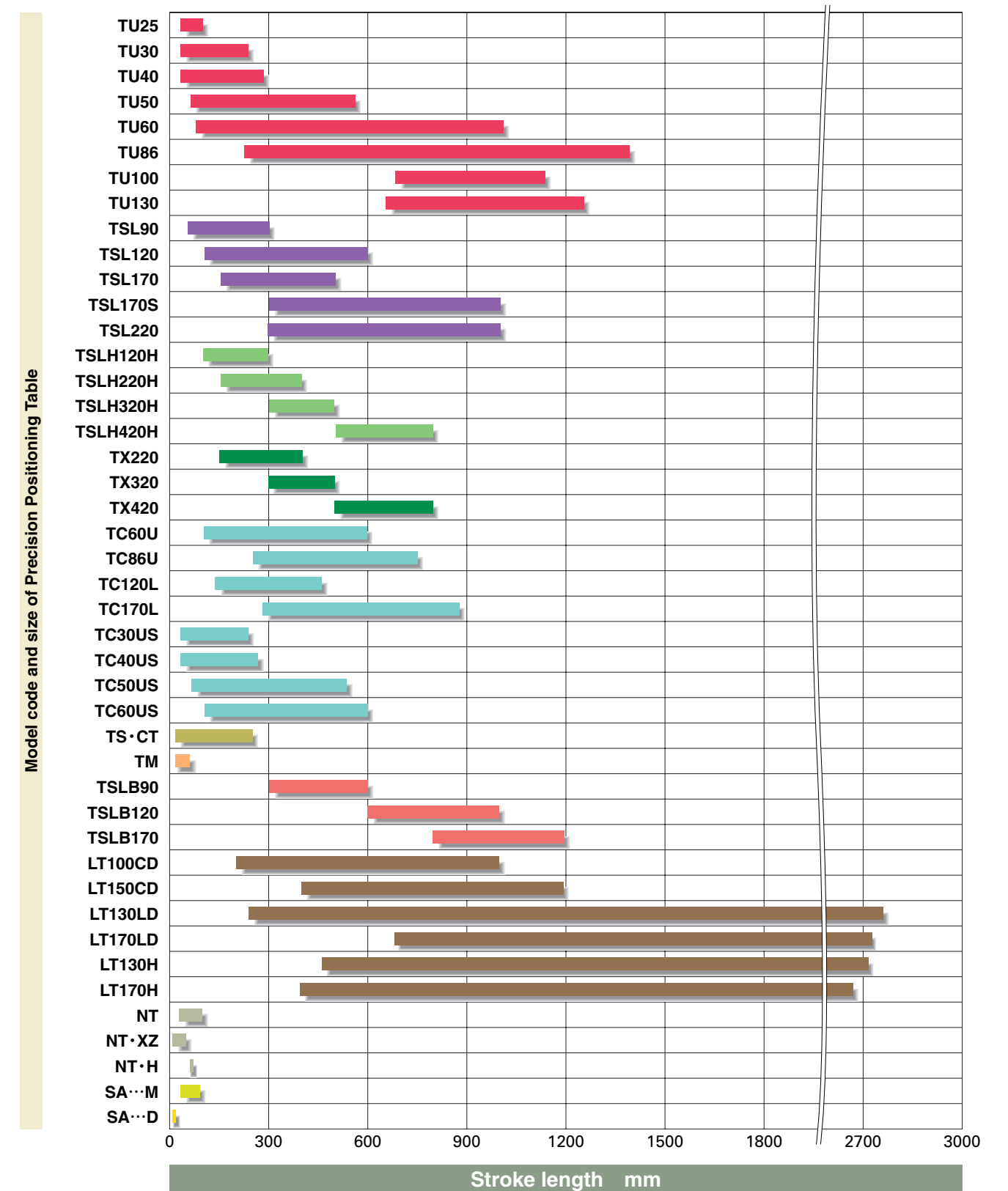

How to see the above graph

● The values shown in the graph are reference values. For details, refer to the separate catalogue of each model.

● Each length in the bar graph represents the standardized range of stroke length.

Repeatability of Precision Positioning Table

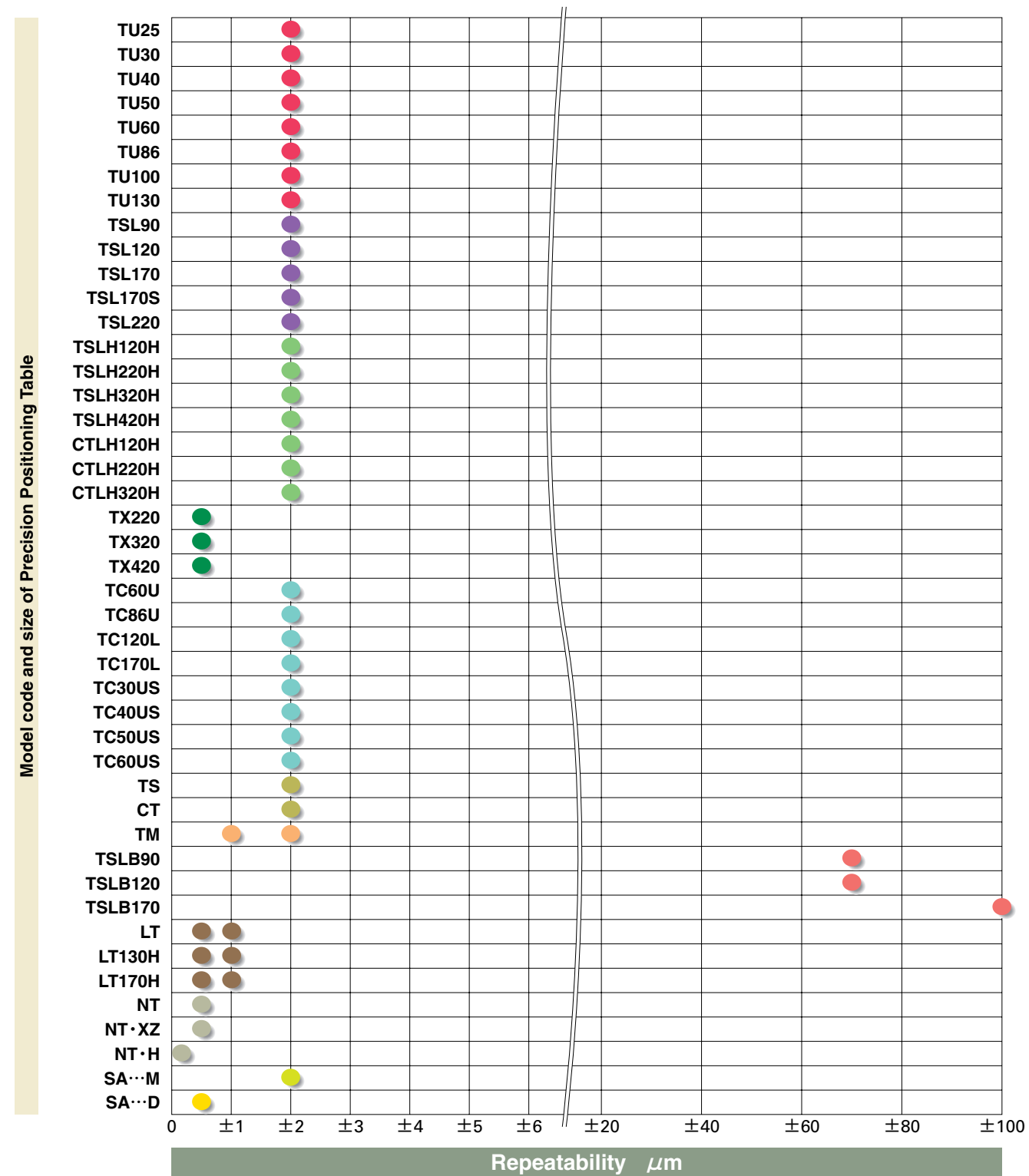

How to see the above graph

- The values shown in the graph are reference values. For details, refer to the separate catalogue of each model.
- The ball screw drive type represents a value for the case where the ground ball screw is selected.
- When 2 or more values are indicated for a model, this means that the applicable value depends on the stroke length.
- For TU, the value of the standard table is indicated.
- CTLH and CT, are tables of 2-axis specification.
- For SA...M and SA...D, the value of the X axis is indicated.

Positioning accuracy of Precision Positioning Table

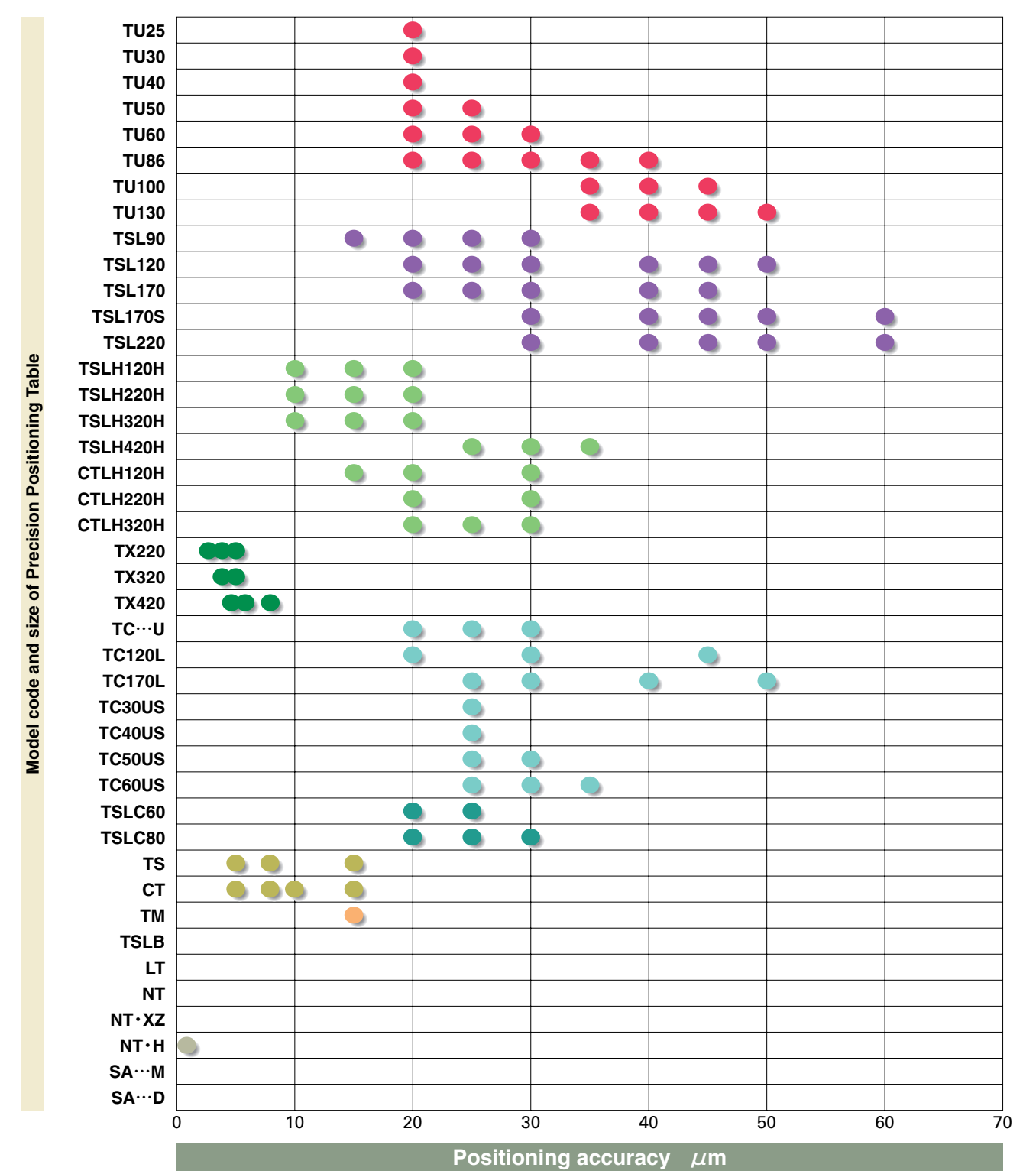

How to see the above graph

- The values shown in the graph are reference values. For details, refer to the separate catalogue of each model.
- The ball screw drive type represents a value for the case where the ground ball screw is selected.
- When 2 or more values are indicated for a model, this means that the applicable value depends on the stroke length.
- For TU, the value of the standard table is indicated.
- CTLH and CT, are tables of 2-axis specification.

Maximum speed of Precision Positioning Table

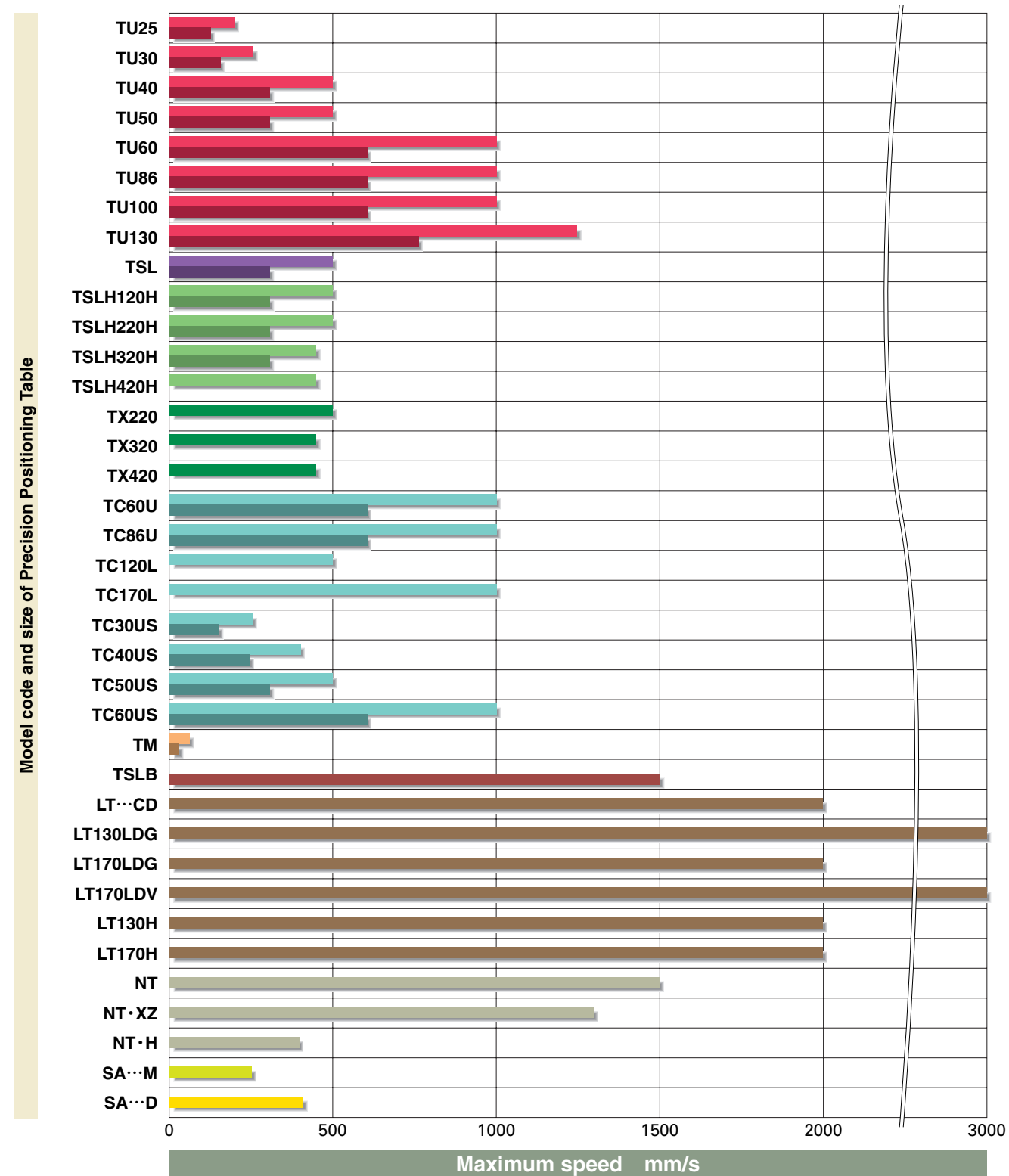

How to see the above graph

- The values shown in the graph are reference values. For details, refer to the separate catalogue of each model.
- For the ball screw drive type, the value based on the selectable maximum ball screw lead length is indicated.
- The upper row indicates a value of AC servo motor specification and the lower row indicates a value of stepping motor specification.
- For the ball screw drive type, some stroke lengths may be limited by the allowable rotation speed of the ball screw.

Maximum load mass of Precision Positioning Table

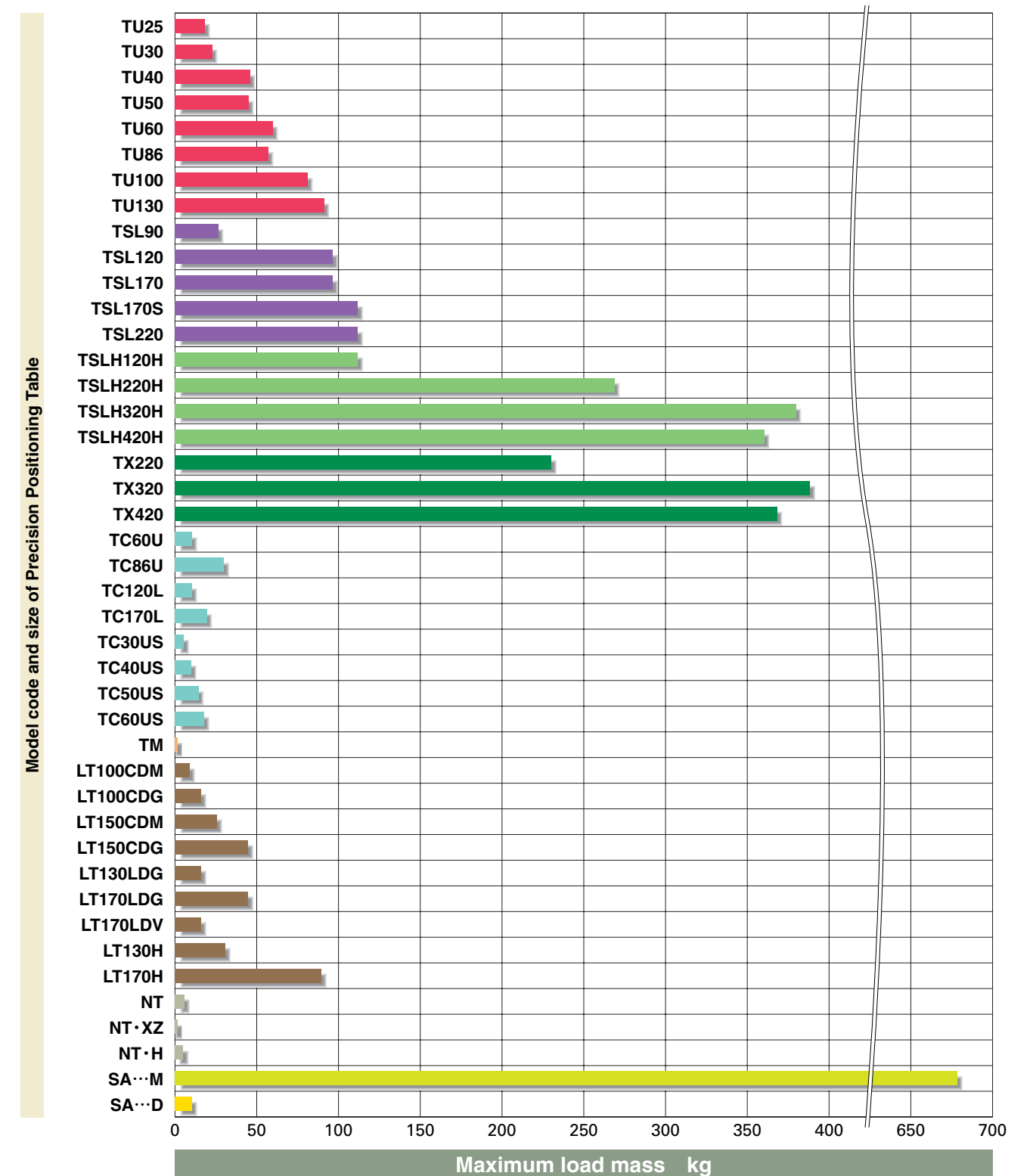

How to see the above graph

- The values shown in the graph are reference values. For details, refer to the separate catalogue for each model.
- For TU, the value of the standard table is indicated.
- For LT, NT and SA...D, the maximum load mass is indicated.
- For TM and SA...M, the allowable load is indicated.

Application of IKO Precision Positioning Tables

- Transferring and positioning axis of precision parts in assembling machine.....D-25
- Positioning axis of detecting head in compact CT scanner for diagnostics of small animalsD-26
- Positioning axis of car body in welding machineD-27
- Transferring axis of Wafer robotD-29
- Positioning axis of Embroidery frame in Multi-head embroidery machinesD-30
- Switching of lens in LCD repairing machineD-31
- Positioning axis of work and camera in high precision assembling machineD-32
- Wafer alignment axis in wafer inspection machineD-33
- Positioning axis of cutter in cardboard machineD-34

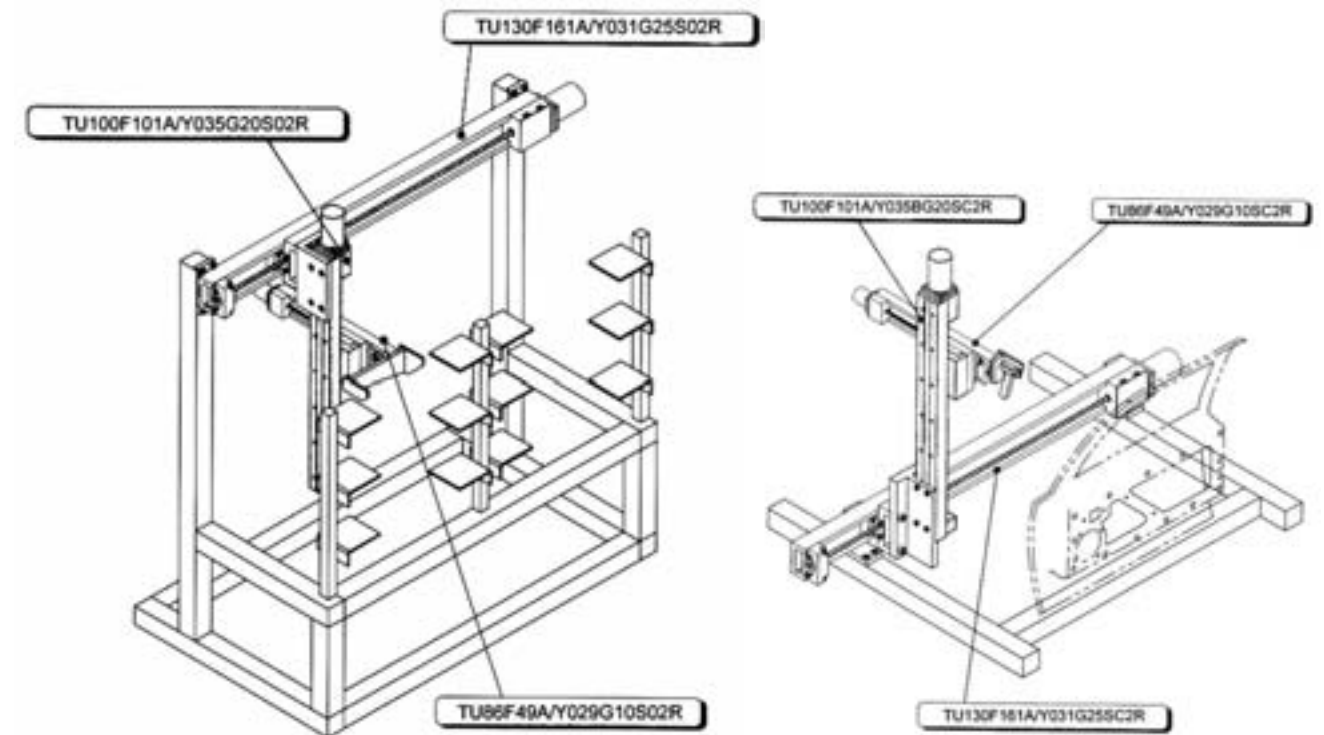
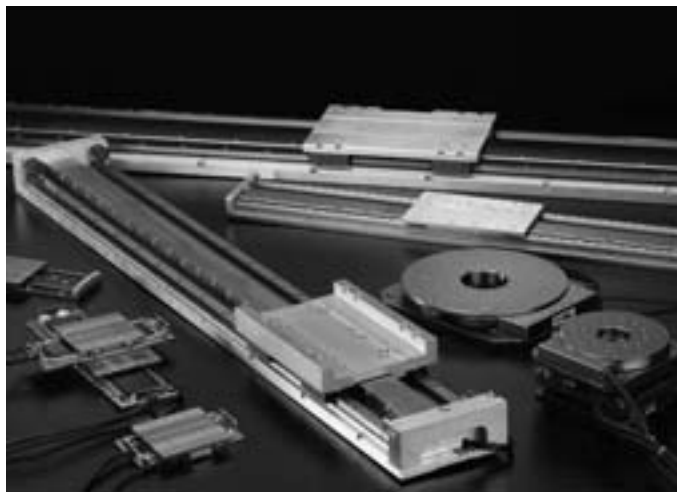

Transferring and positioning axis of precision parts in assembling machine

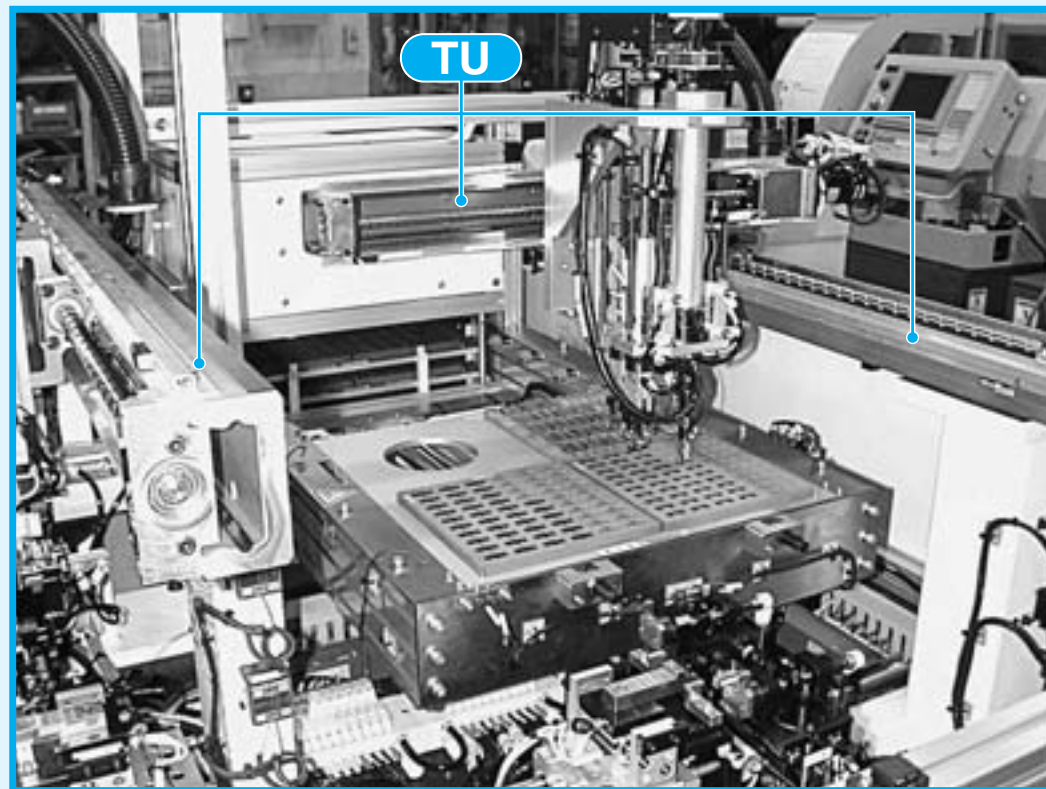

Positioning axis of detecting head in compact CT scanner for diagnostics of small animals

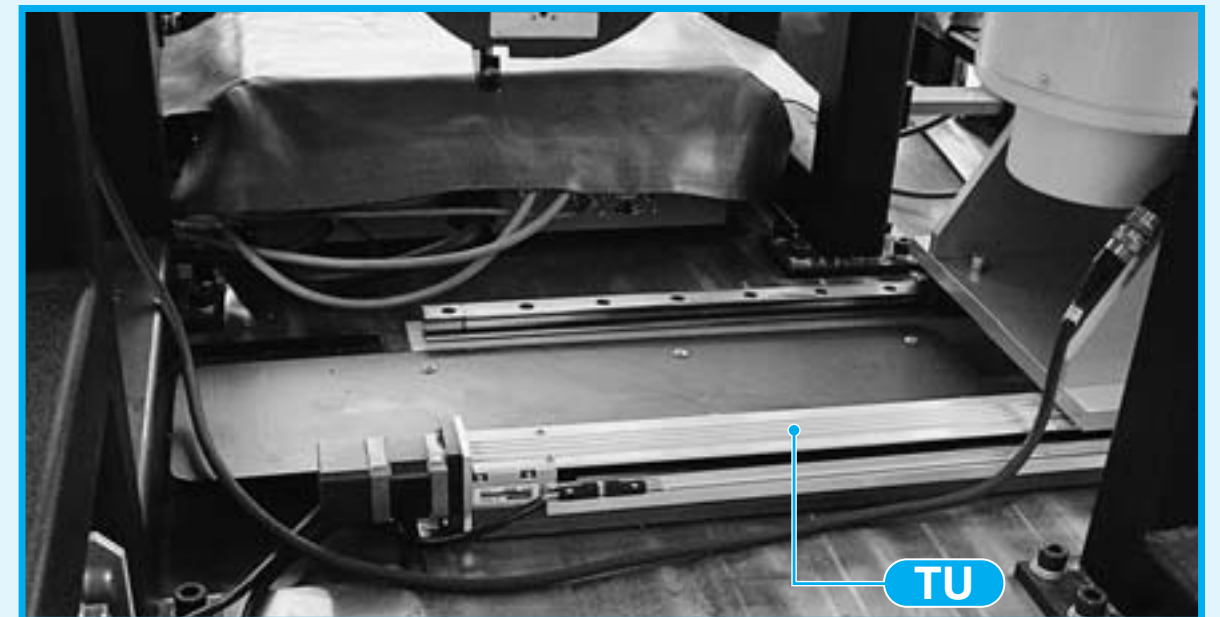

Positioning axis of car body in welding machine

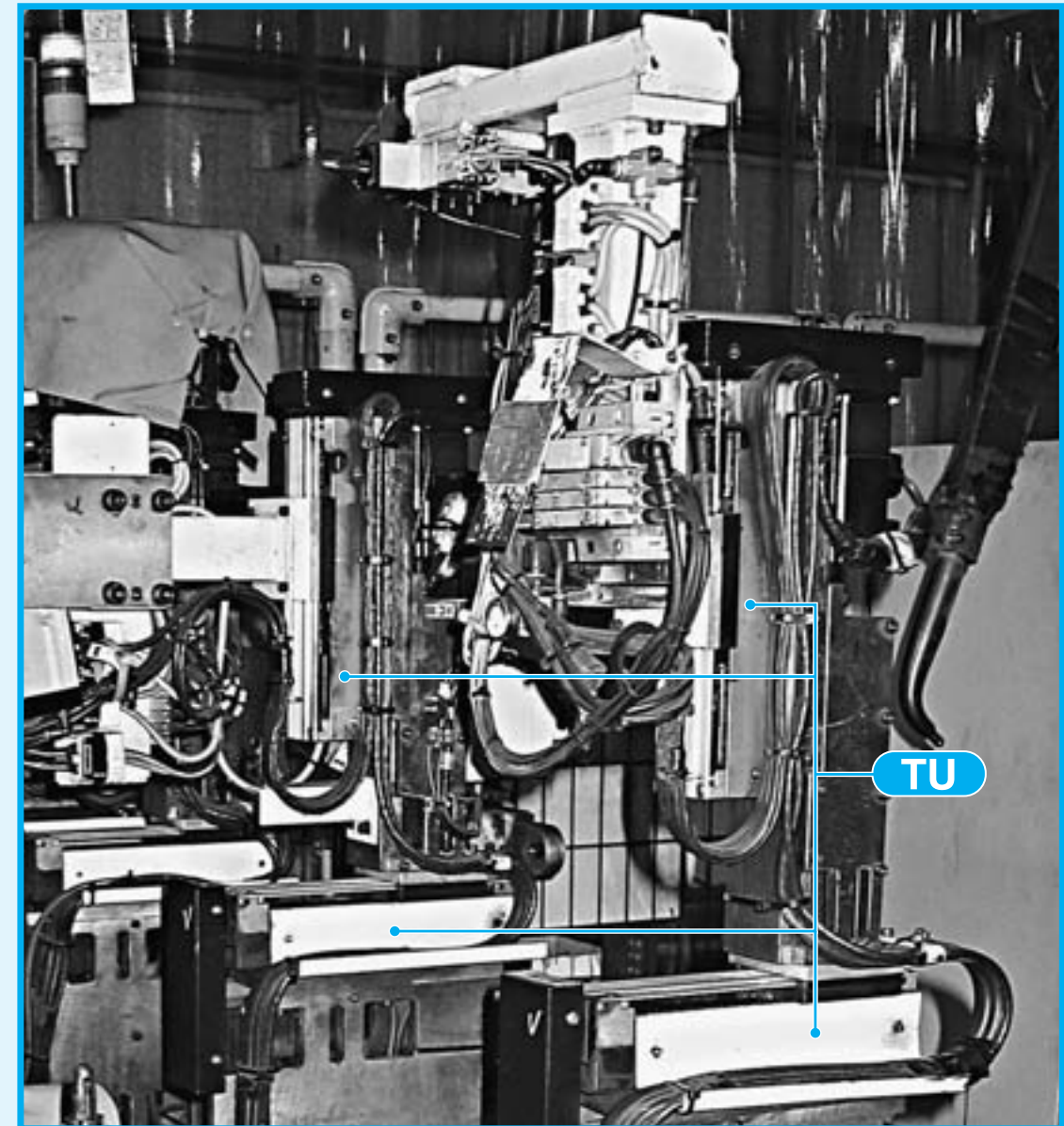
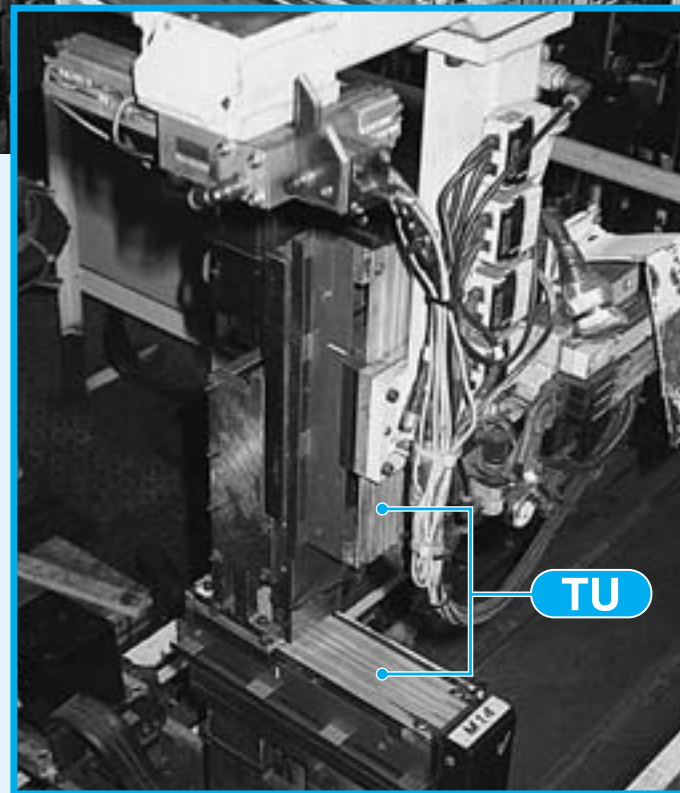
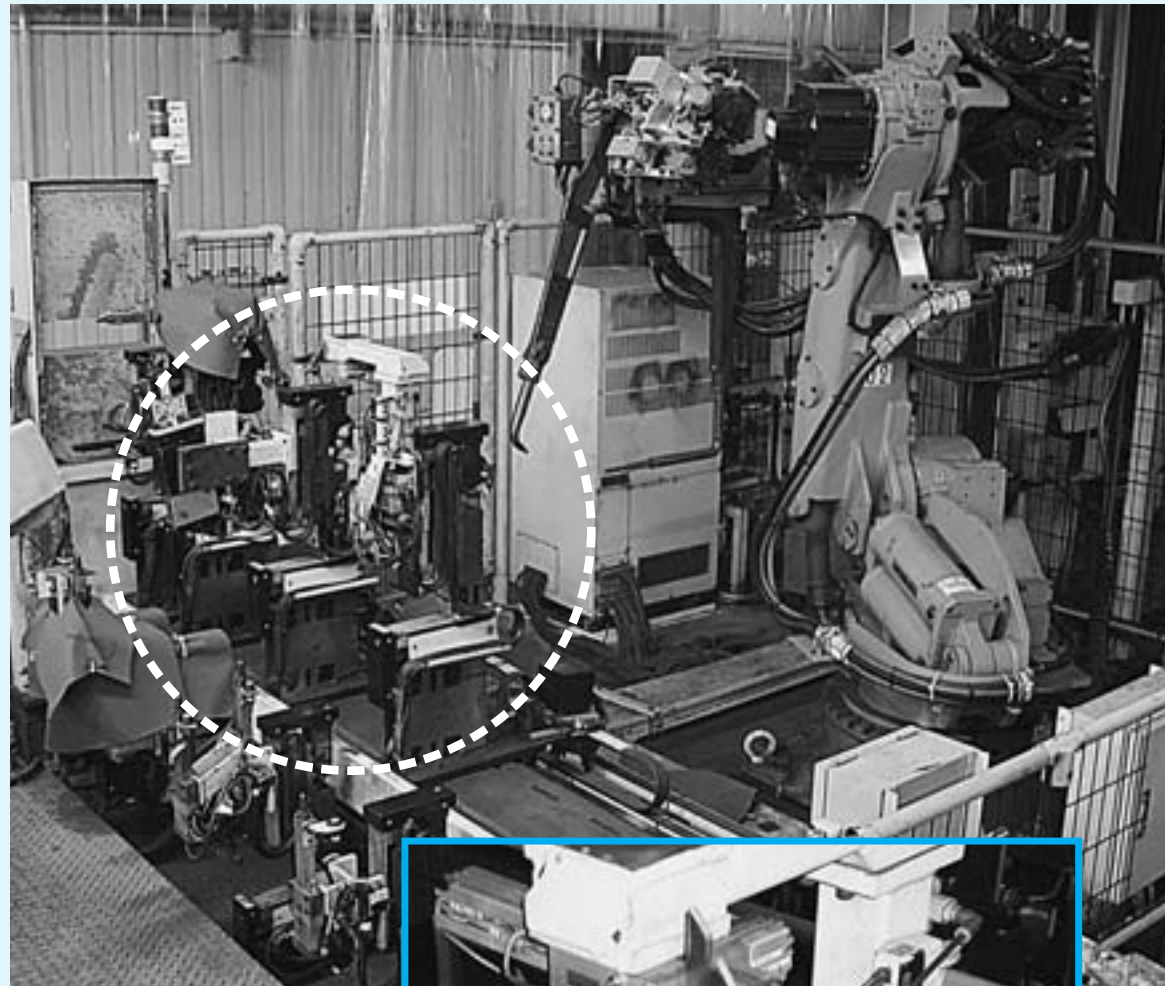

Transferring axis of Wafer robot

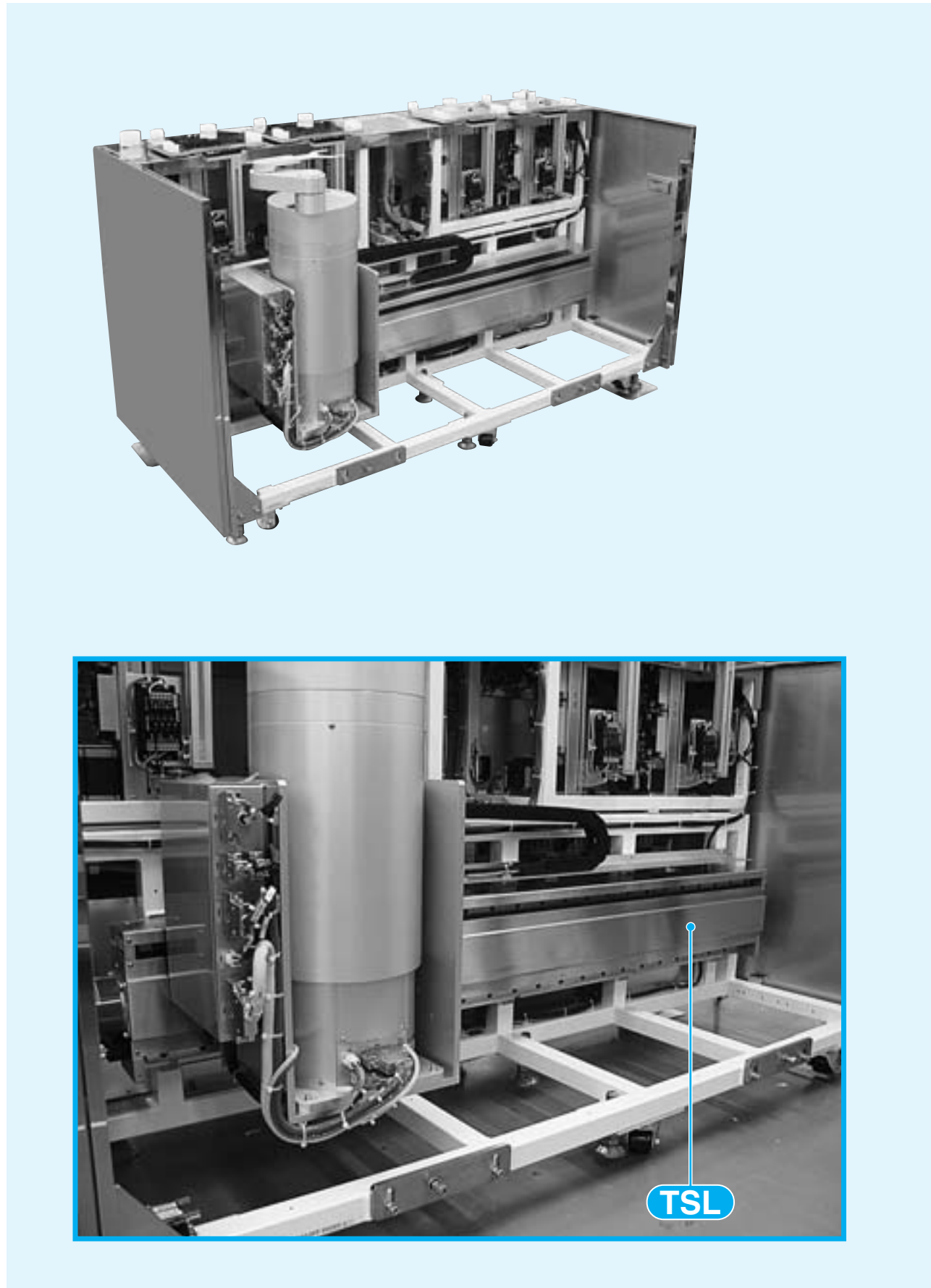

Positioning axis of Embroidery frame in Multi-head embroidery machines

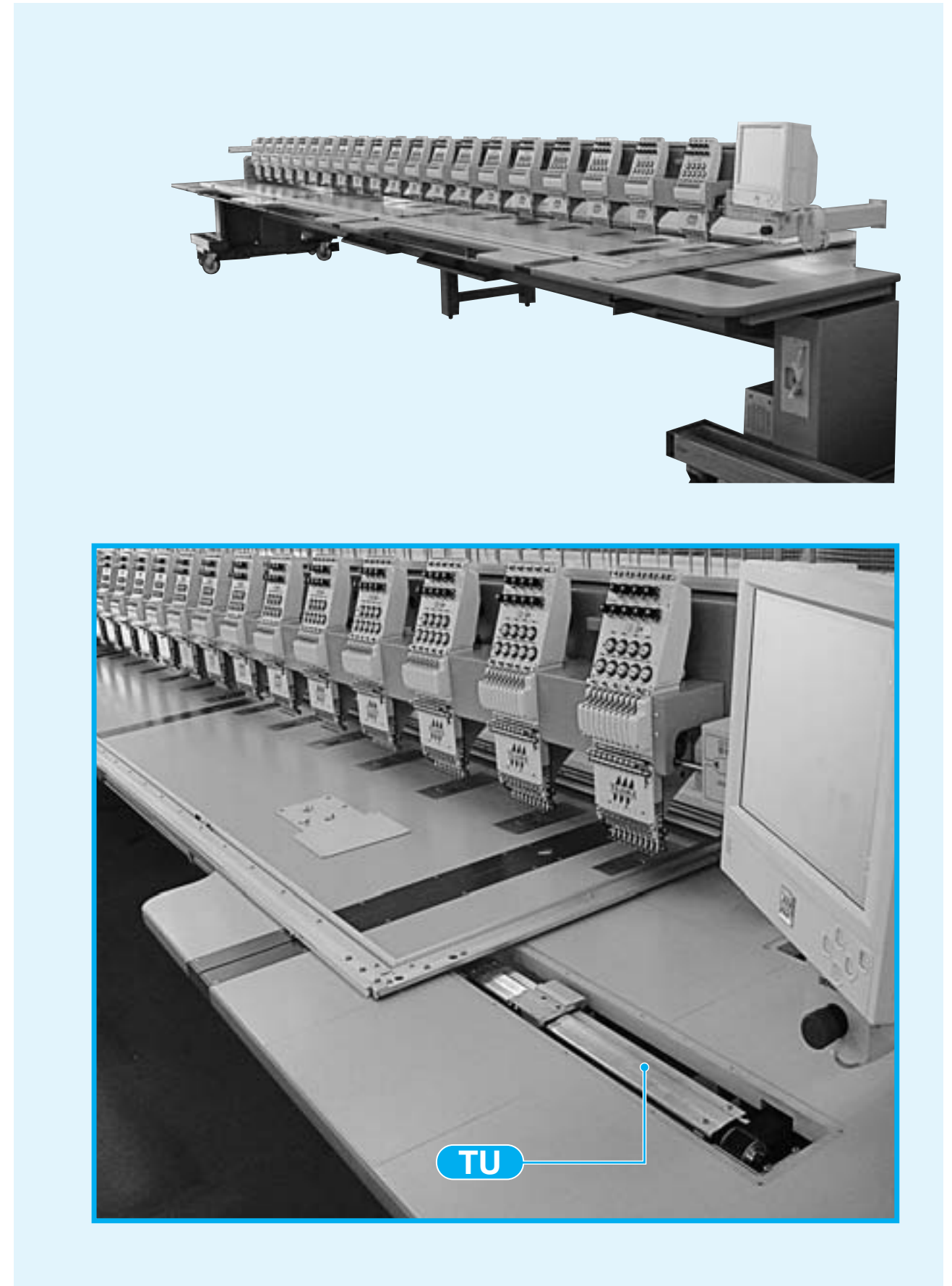

Switching of lens in LCD repairing machine

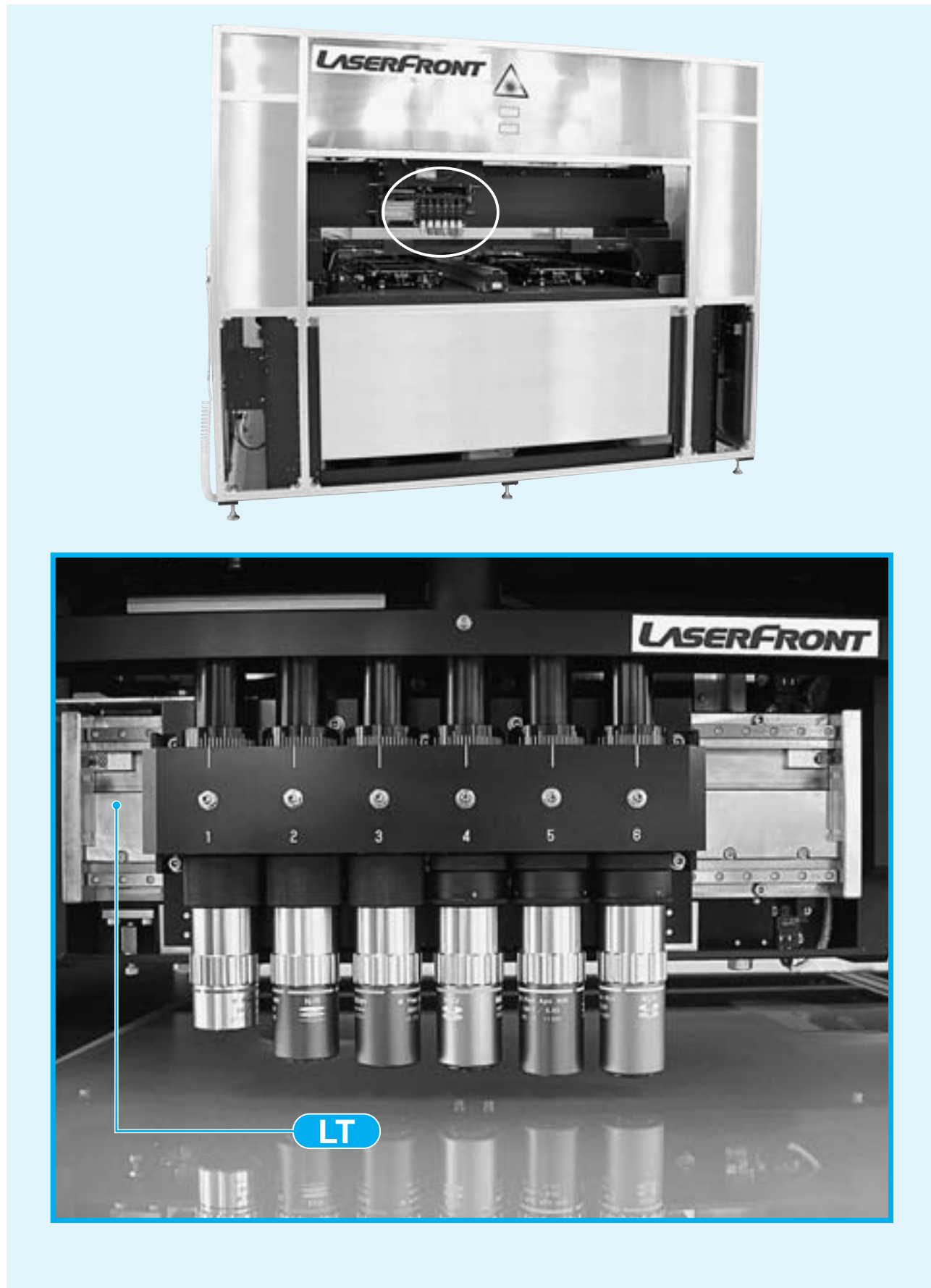

Positioning axis of work and camera in high precision assembling machine

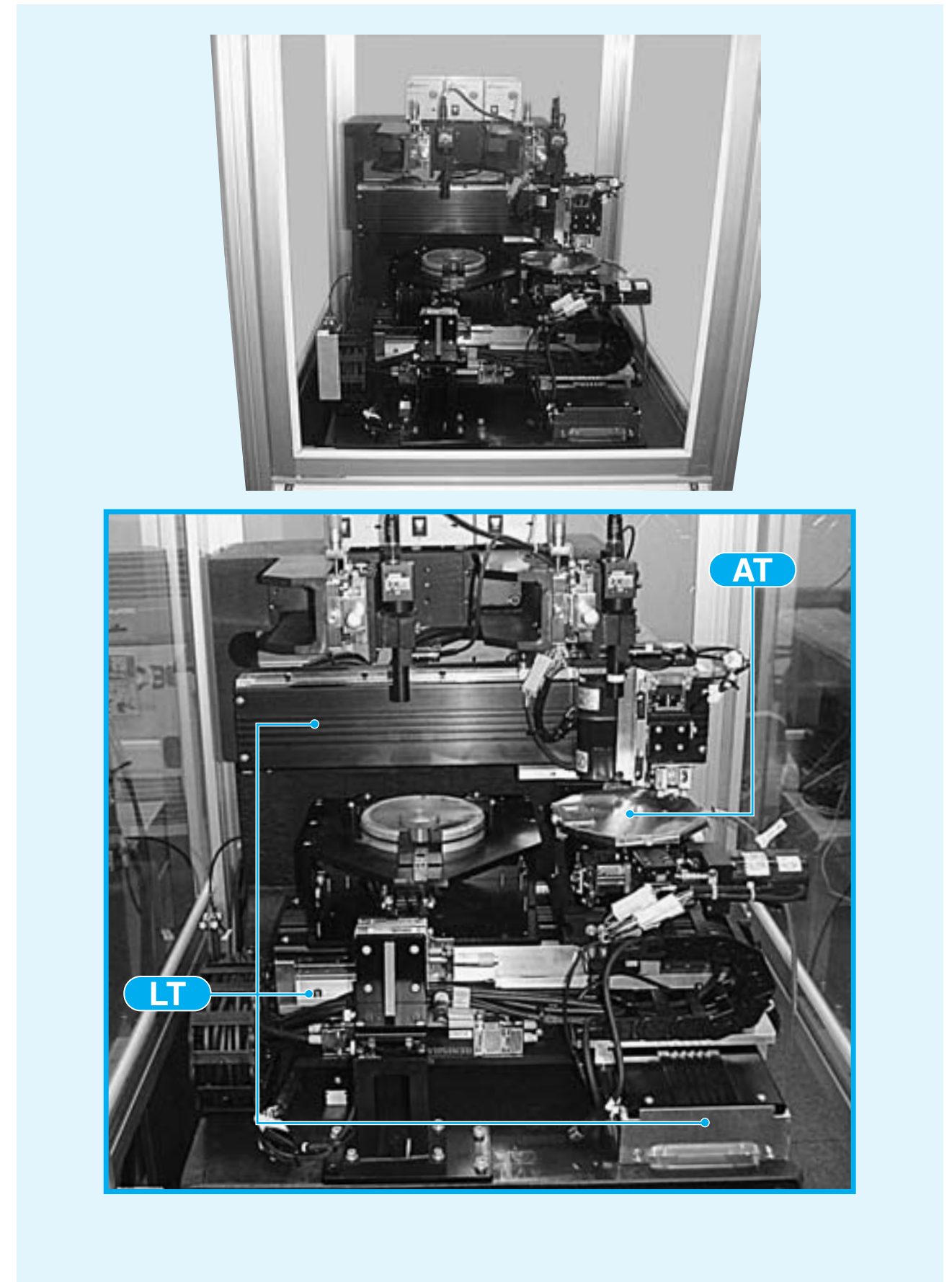

Wafer alignment axis in wafer inspection machine

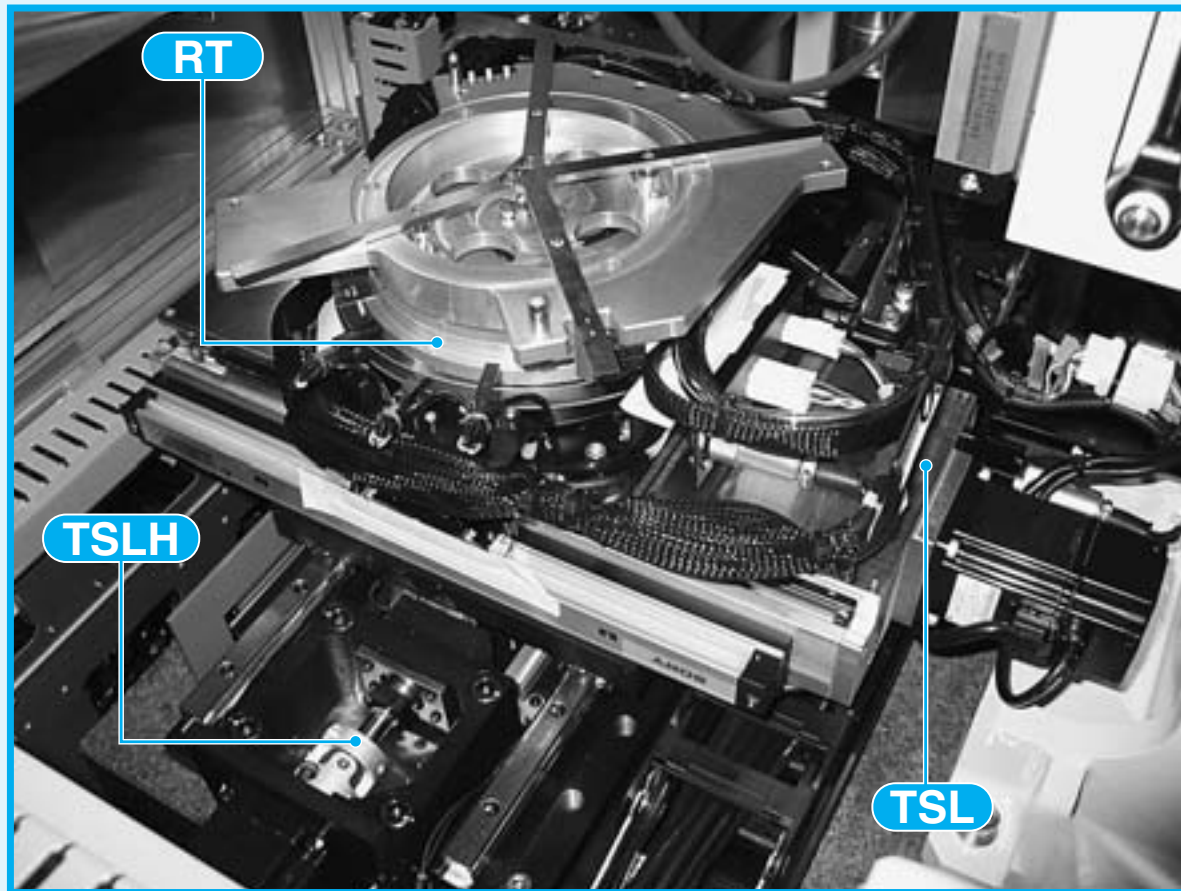

Positioning axis of cutter in cardboard machine

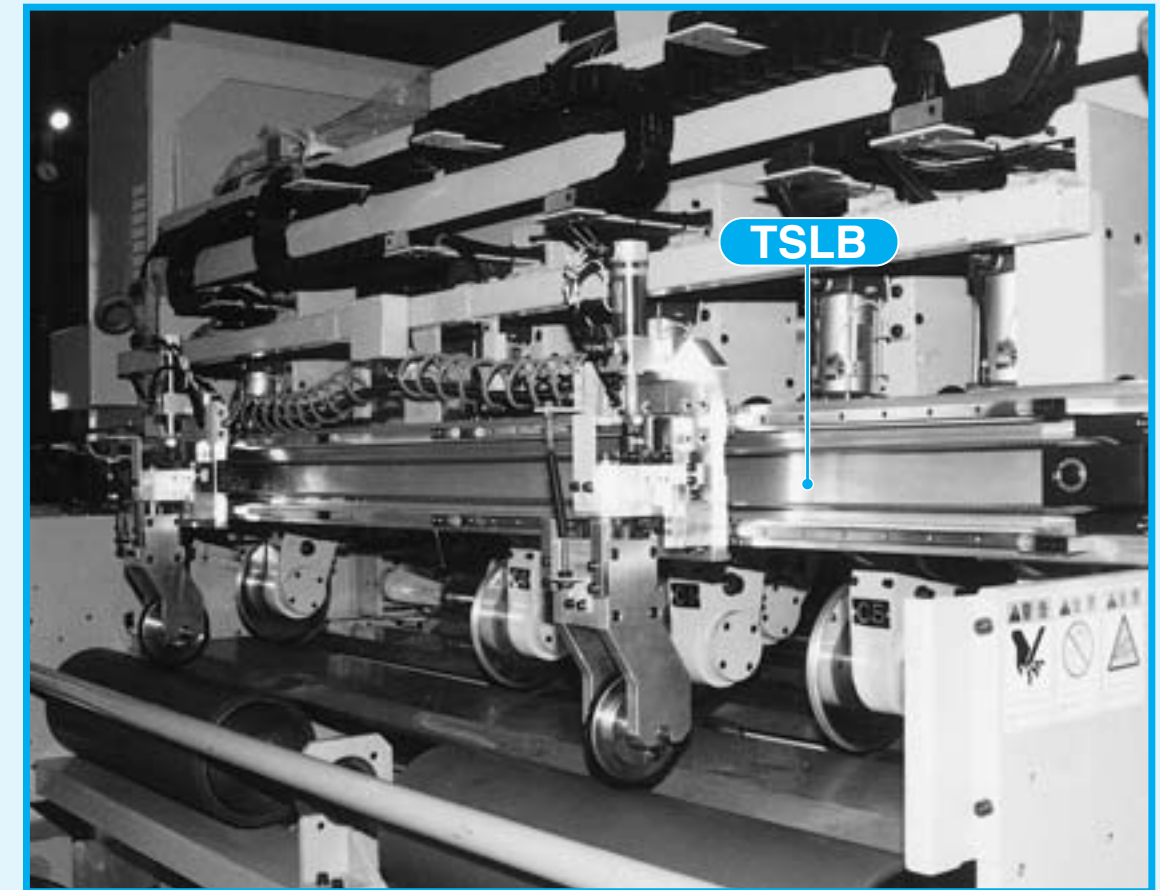
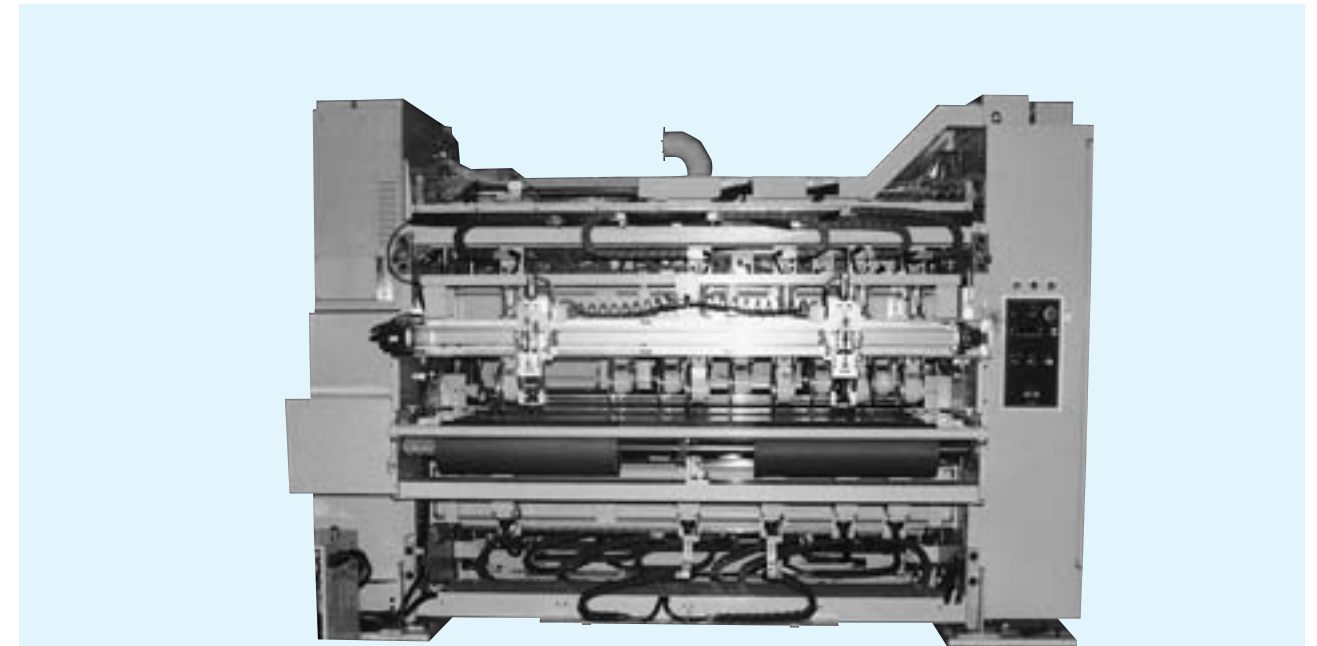

Application form for TU table

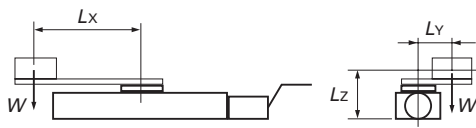
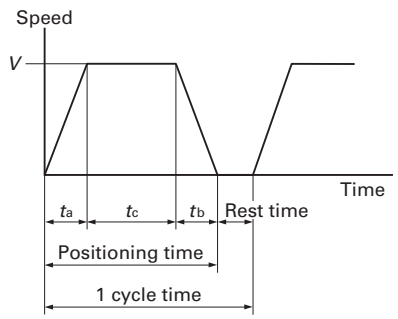
Company name		
Address		
Phone :		Fax :
Contact person		E-mail :
Standard Table Part Number :		
Attached document	<input type="checkbox"/> Customer drawing, <input type="checkbox"/> Specification sheet	
Production quantity	Proto type _____ sets (When ____/____/____) Production _____ sets/ <input type="checkbox"/> Lot, <input type="checkbox"/> Monthly, <input type="checkbox"/> Yearly (Start from ____/____/____)	
Application detail Machine model and description : Purpose of moving, or positioning :		
Mounting condition <input type="checkbox"/> Horizontal <input type="checkbox"/> Lateral <input type="checkbox"/> Vertical <input type="checkbox"/> Other (please describe detail)		
Load amount and position		
		
Distance L_x		mm
Distance L_y		mm
Distance L_z		mm
Driving pattern		
		
Acceleration/Deceleration time $t_a (=t_b)$		sec.
Constant speed time t_c		sec
Positioning time		sec
Rest time		sec.
Stroke length		mm
Maximum speed V		m/sec.
Number of strokes		cycle/min
Required accuracy <input type="checkbox"/> Standard <input type="checkbox"/> Special as below		
Positioning accuracy		mm
Repeatability	±	mm
Resolution		mm
Running parallelism B		mm
Requirement for inspection :		

Ball screw type	<input type="checkbox"/> Ground ball screw <input type="checkbox"/> Lead : mm	
	<input type="checkbox"/> Rolled ball screw	
Atmosphere	<input type="checkbox"/> Normal <input type="checkbox"/> Other <input type="checkbox"/> Low/High temperature : _____ to _____ °C <input type="checkbox"/> Humidity _____ % <input type="checkbox"/> Dusty condition (Describe _____) <input type="checkbox"/> Clean room condition : Class _____ <input type="checkbox"/> Vacuum condition _____ Torr. <input type="checkbox"/> Other descriptions (Please describe)	
Lubricant :	<input type="checkbox"/> Standard <input type="checkbox"/> Special (Name/Brand : _____)	
Sensor specifications Sensor attached : <input type="checkbox"/> No need, <input type="checkbox"/> Need (fill in following) <input type="checkbox"/> Only sensor rails		
Wiring	Mounting sensor	Sensor type
<input type="checkbox"/> Need →	<input type="checkbox"/> Origin →	<input type="checkbox"/> Standard
<input type="checkbox"/> No need	<input type="checkbox"/> Pre-origin	<input type="checkbox"/> Special (Detail requirement) ;
	<input type="checkbox"/> CW/CCW Limit	
Motor Model (manufacture) : _____ (_____) <input type="checkbox"/> Arranged by IKO		
Specification of Electric devices		
Driver	<input type="checkbox"/> Need→ <input type="checkbox"/> No need	Model : _____ (Mfg. : _____)
Controller	<input type="checkbox"/> Need→ <input type="checkbox"/> No need	Model : _____ (Mfg. : _____)
Motor cord	<input type="checkbox"/> Need→ <input type="checkbox"/> No need	Model : _____ (Mfg. : _____)
Pulse/limit cord	<input type="checkbox"/> Need→ <input type="checkbox"/> No need	Model : _____ (Mfg. : _____)
Encoder cord	<input type="checkbox"/> Need→ <input type="checkbox"/> No need	Model : _____ (Mfg. : _____)
Other information		

FAX to Technical support of Precision Positioning Table ;

Asia : +81 3-3447-7637

Europe : +49 211-427693

U.S.A : +1 310-609-3916



NIPPON THOMPSON CO., LTD.

Head office : 19-19 Takanawa 2-chome
 Minato-ku, Tokyo 108-8586, Japan
 Phone : +81 (0)3-3448-5850
 Fax : +81 (0)3-3447-7637
 E-mail : ntt@ikonet.co.jp
 URL : <http://www.ikont.co.jp/eg/>
 Plant : Gifu, Kamakura

NIPPON THOMPSON CO., LTD.

● ASEAN REPRESENTATIVE OFFICE
 Level 8, #1 Silom Road, Silom, Bangrak, Bangkok
 Thailand 10500
 Phone: +66 (0)2-231-8278
 Fax: +66 (0)2-231-8121
 E-mail: ntar@ikonet.co.jp

IKO-THOMPSON (SHANGHAI) LTD.

● 1402-1404 Sunyoung Center
 28 Xuanhua Road, Shanghai
 People's Republic of China 200050
 Phone: +86 (0)21-3250-5525
 Fax: +86 (0)21-3250-5526
 E-mail: ntc@ikonet.co.jp

IKO INTERNATIONAL, INC. <http://www.ikont.com/>

- 91 Walsh Drive
 Parsippany, NJ 07054
 U.S.A.
 Phone: +1 973-402-0254
 Toll Free: 1-800-922-0337
 Fax: +1 973-402-0441
 E-mail: eco@ikonet.co.jp
- 500 East Thorndale Avenue
 Wood Dale, IL 60191
 U.S.A.
 Phone: +1 630-766-6464
 Toll Free: 1-800-323-6694
 Fax: +1 630-766-6869
 E-mail: mwo@ikonet.co.jp
- 20170 South Western Avenue
 Torrance, CA 90501
 U.S.A.
 Phone: +1 310-609-3988
 Toll Free: 1-800-252-3665
 Fax: +1 310-609-3916
 E-mail: wco@ikonet.co.jp
- 2150 Boggs Road, Suite 100
 Duluth, GA 30096
 U.S.A.
 Phone: +1 770-418-1904
 Toll Free: 1-800-874-6445
 Fax: +1 770-418-9403
 E-mail: seo@ikonet.co.jp
- 8105 N. Beltline Road
 Suite 130, Irving, TX 75063
 U.S.A.
 Phone: +1 972-929-1515
 Toll Free: 1-800-295-7886
 Fax: +1 972-915-0060
 E-mail: swo@ikonet.co.jp

NIPPON THOMPSON EUROPE B.V. <http://www.ikont.eu/>

- Sheffieldstraat 35-39
 3047 AN Rotterdam
 The Netherlands
 Phone: +31 (0)10-4626868
 Fax: +31 (0)10-4626099
 E-mail: nte@ikonet.co.jp
- Mündelheimer Weg 56
 40472 Düsseldorf
 Germany
 Phone: +49 (0)211-414061
 Fax: +49 (0)211-427693
 E-mail: ntd@ikonet.co.jp
- Im Gewerbepark D 30
 93059 Regensburg
 Germany
 Phone: +49 (0)941-206070
 Fax: +49 (0)941-2060719
 E-mail: ntdr@iko-nt.de
- Gruben Str.95c
 66540 Neunkirchen
 Germany
 Phone: +49 (0)6821-999-860
 Fax: +49 (0)6821-999-8626
 E-mail: ntdn@iko-nt.de
- 2 Vincent Avenue, Crownhill
 Milton Keynes Bucks MK8 OAB
 United Kingdom
 Phone: +44 (0)1908-566144
 Fax: +44 (0)1908-565458
 E-mail: sales@iko.co.uk
- Autovia Madrid-Barcelona, Km. 43,700
 Polig. Ind. AIDA, A-8, Ofic. 2, 1ª
 19200-Azuqueca de Henares
 Guadalajara, Spain
 Phone: +34 949-263390
 Fax: +34 949-263113
 E-mail: nts@ikonet.co.jp
- Roissypole Le Dôme
 2 rue de La Haye
 BP 15950 Tremblay en France
 95733 Roissy C. D. G. Cedex
 France
 Phone: +33 (0)1-48165739
 Fax: +33 (0)1-48165746
 E-mail: ntf@ikonet.co.jp

Although all data in this catalog has been carefully compiled to make the information as complete as possible, NIPPON THOMPSON CO., LTD. shall not be liable for any damages whatsoever, direct or indirect, based upon any information in this catalog. NIPPON THOMPSON CO., LTD. makes no warranty, either express or implied, including the implied warranty of merchantability or fitness for a particular purpose.