

CF

IKO Cam Followers are bearings provided with a stud in which needle rollers are assembled in a thick outer ring, having a small coefficient of friction and excellent rotating performance designed for outer ring rotation. These products having high rigidity and accuracy are widely used for machine tools, industrial robots, electronic parts, OA devices as follower bearings for various cam mechanisms and guide rollers for linear motion.

The head of the stud is provided with a hexagon hole so that it can be surely tightened with a hex wrench.

Its IKO original lubrication structure permits a grease-up operation from the head of the stud, so this allows the user to make a system design freely without any limitation on the direction of lubrication.

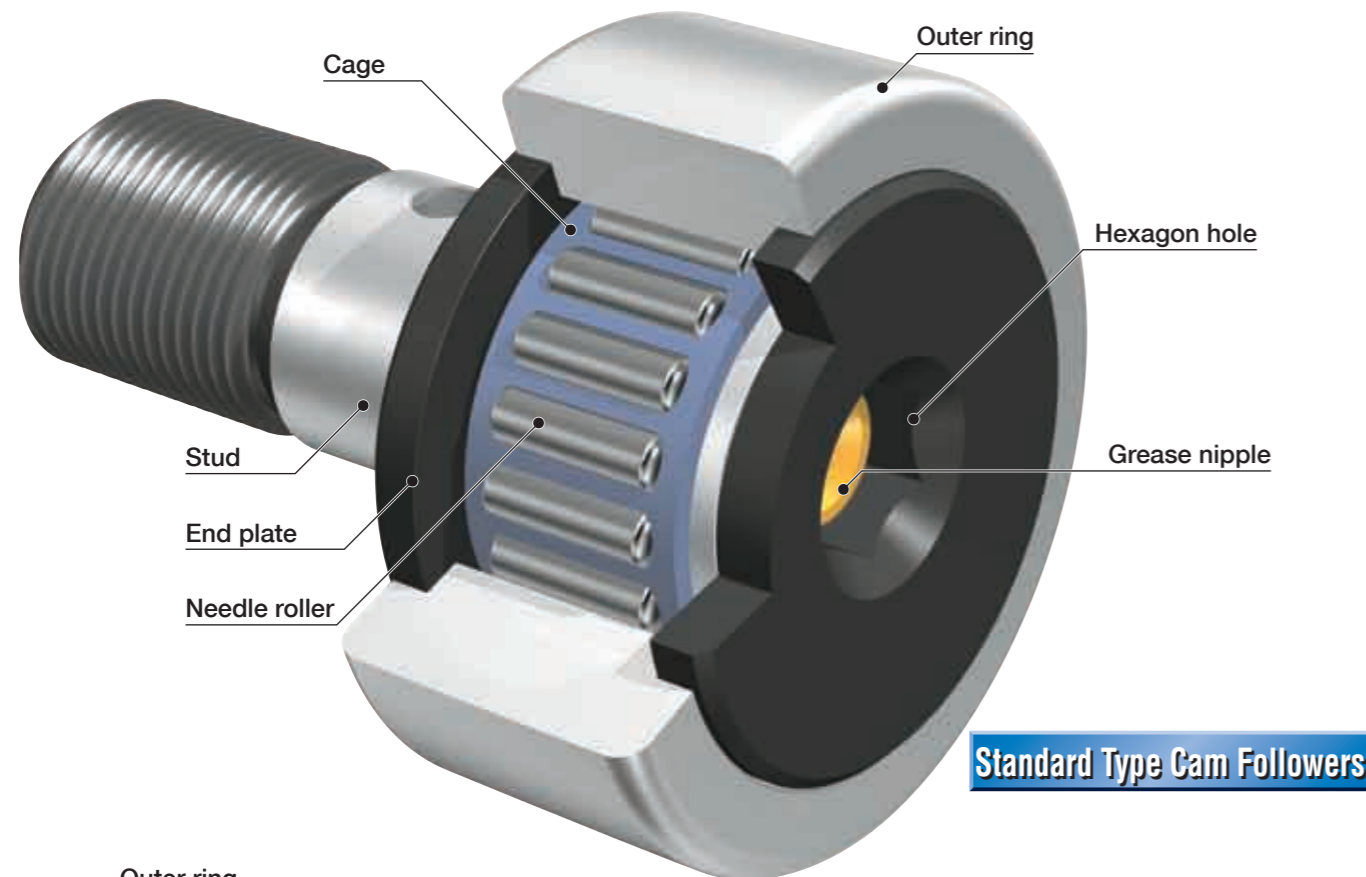

Standard Type Cam Followers

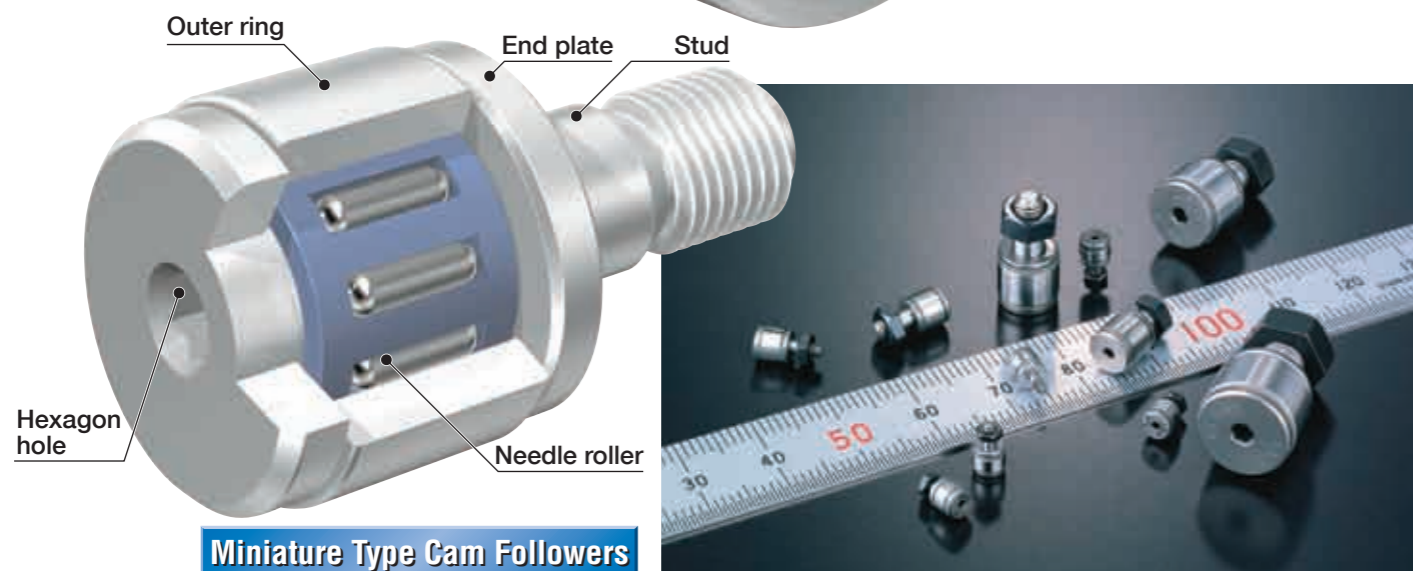

Miniature Type Cam Followers

Variety and Originality

Cam Follower Series with reliability and actual operation results

The excellent features of **IKO** Cam Followers are presented below.

1 Full product lineup To page 7

The product lineup including the miniature type with very small dimensions, type provided with a thrust washer strong in an mounting error, and maintenance-free type with a prepacked solid lubricant is complete.

2 Abundant product specifications selectable for each application To page 13

The customer can select the optimum product specifications including material type, roller guide type, seal section structure, and external diameter surface of outer ring according to each application.

3 Provided with a hexagon hole that facilitates mounting To page 15

The head of the stud is provided with a hexagon hole and this permits easy mounting with a hex wrench.

4 **IKO** original structure that permits lubrication from the head of the stud To page 16

Grease-up can be performed from the head of the stud though the product is provided with a hexagon hole. The direction of lubrication is not limited.

5 C-Lube Unit for Cam Followers based on a new concept To page 17

C-Lube Unit to supply the lubricant to the external diameter surface of the outer ring and the track surface of Cam Followers. If this product is combined with Cam Followers, periodic lubrication on the track surface is not required and friction and abrasion can be reduced.

1 Full product lineup 1

Miniature Type Cam Followers

Stud diameter mm
2 to 6

CFS

In this bearing, very thin needle rollers are assembled in the outer ring. This product is designed as a compact type with a small external diameter of the outer ring for the stud diameter. The product is used in electronic parts, OA devices, miniature index devices, etc.

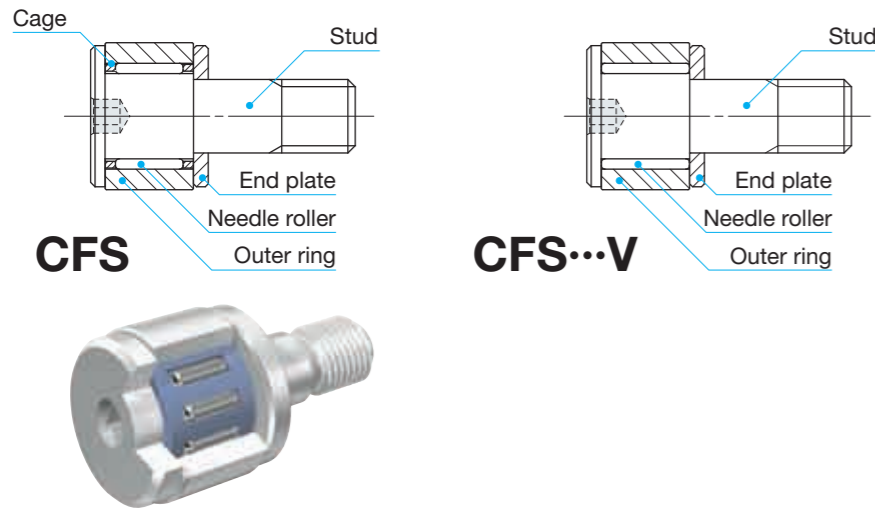

Selectable product specifications

Material type	No symbol		Carbon steel
	F		Stainless steel
Roller guide type	No symbol		Caged
	V		Full complement
Seal structure	No symbol		Shield type
	UU		Sealed type
Shape of outer ring	No symbol		Cylindrical outer ring
	R		Crowned outer ring

To page 31

Standard Type Cam Followers

Stud diameter mm
3 to 30

CF...B

This is a basic type of Cam Followers. The available size variation of stud diameter ranges from 3 mm min. to 30 mm max.

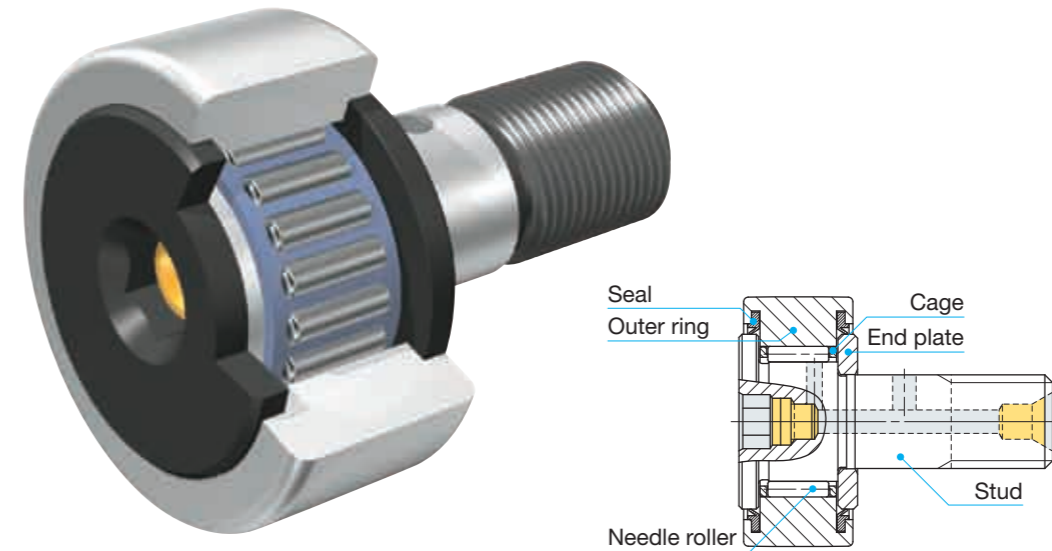

Selectable product specifications

Material type	No symbol		Carbon steel
	F		Stainless steel
Roller guide type	No symbol		Caged
	V		Full complement
Seal structure	No symbol		Shield type
	UU		Sealed type
Shape of outer ring	No symbol		Cylindrical outer ring
	R		Crowned outer ring

To page 35

Thrust Disk Type Miniature Cam Followers

Stud diameter mm
1.4 to 6

CFS...W

Miniature Type Cam Followers which is provided with a thrust disk made of special synthetic resin excellent in abrasion resistance and heat resistance. This product receives an axial load of the outer ring that is caused by mounting error to reduce friction and abrasion of the slide surface.

**The smallest in the world !
Cam Followers with such a small
stud diameter of 1.4mm !!**



CFS1.4WV with a stud diameter of 1.4 mm and a small external diameter of only 4 mm of the outer ring. The built-in thrust disk receives an axial load of the outer ring that is caused by mounting error.

Five features of CFS1.4WV

- 1** The stud diameter is only $\phi 1.4\text{mm}$.
- 2** The external diameter of the outer ring is only $\phi 4\text{mm}$.
- 3** Provided with a hexagon hole that facilitates mounting
- 4** Full complement type with a large load capacity
- 5** Provided with a thrust disk that is strong in mounting error

Selectable product specifications

Material type	No symbol		Carbon steel
	F		Stainless steel
Roller guide type	No symbol		Caged
	V		Full complement
Seal structure	No symbol		Shield type
	UU		Sealed type
Shape of outer ring	No symbol		Cylindrical outer ring
	R		Crowned outer ring

To page 33

Thrust Disk Type Cam Followers

Stud diameter mm
3 to 20

CF...WB

This product is provided with a thrust disk made of special synthetic resin excellent in abrasion resistance and heat resistance, so this thrust disk receives an axial load of the outer ring that is caused by mounting error to prevent the slide surface against friction and abrasion.

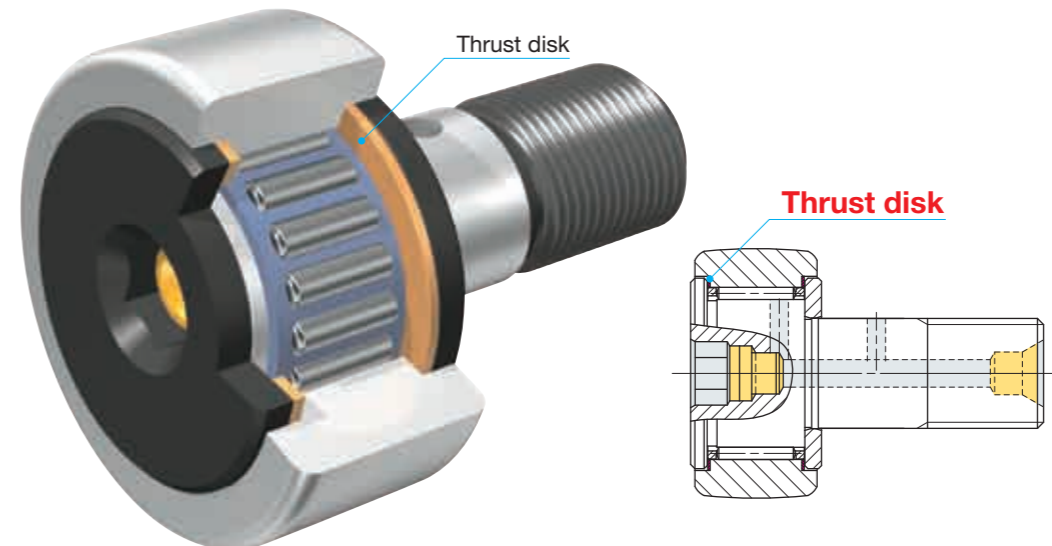

Selectable product specifications

Material type	No symbol		Carbon steel
	F		Stainless steel
Roller guide type	No symbol		Caged
	V		Full complement
Seal structure	No symbol		Shield type
	UU		Sealed type
Shape of outer ring	No symbol		Cylindrical outer ring
	R		Crowned outer ring

To page 39

1 Full product lineup 2

C-Lube Cam Followers

Stud diameter mm
5 to 20

CF...WB.../SG

This is a maintenance-free product in which the thermosetting solid lubricant "C-Lube" is prepacked in the bearing clearance. "C-Lube" is a lubricant resulting from thermosetting a lot of lubricating oil and fine-particle ultra polymeric polyolefin. When the bearing rotates, a proper quantity of lubricant always oozes out onto the raceway from "C-Lube" to keep the lubricating performance of the bearing for a long time.

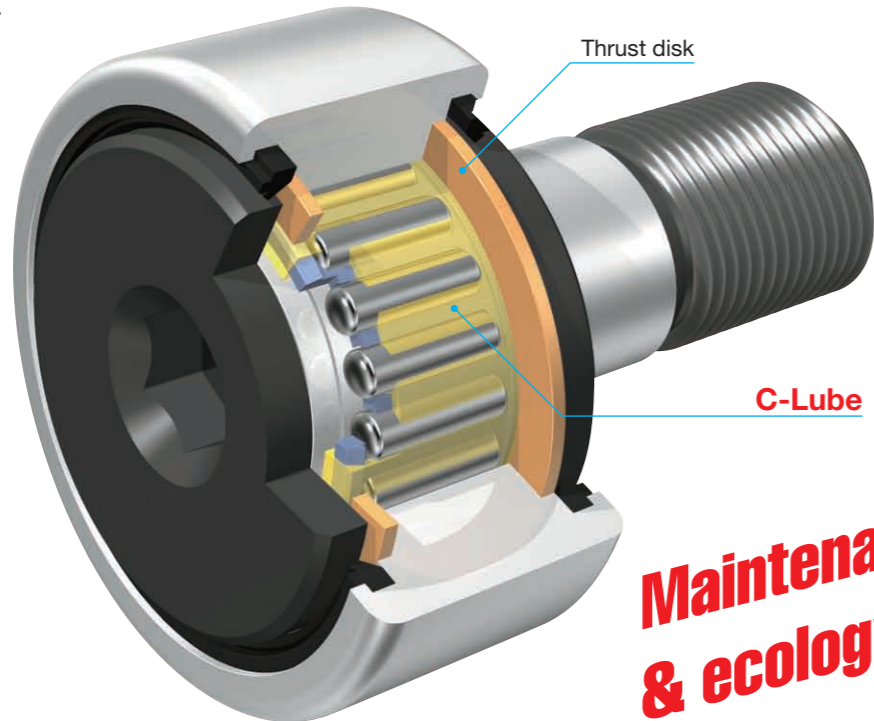

Selectable product specifications

Material type	No symbol	Carbon steel
	F	Stainless steel
Roller guide type	No symbol	Caged
	V	Full complement
Seal structure	No symbol	Shield type
	UU	Sealed type
Shape of outer ring	No symbol	Cylindrical outer ring
	R	Crowned outer ring



Maintenance-free & ecology

《Rotation endurance test》

Test conditions	
Sample	CF10WBUUR/SG
Lubricating condition	C-Lube only without grease prepacked
Rotation speed	1000 rpm
Ambient temperature	Room temperature

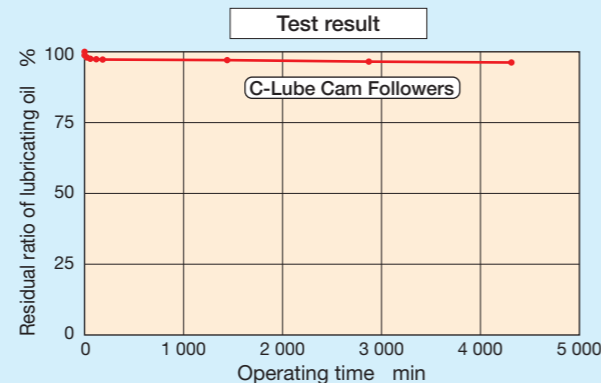
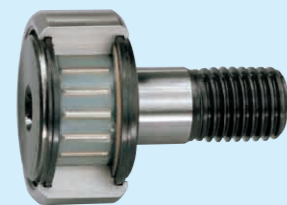

To page 41

IKO A combination with C-Lube unit for Cam Followers is most suitable

A combination with "IKO C-Lube unit for Cam Followers" makes both inside of Cam Follower and track surface maintenance-free.



To page 17

Solid Eccentric Stud Type Cam Followers

Stud diameter mm
6 to 18

CFES...B

As the solid eccentric stud is rotated, the external diameters of the outer rings can be leveled when several pieces are used. The eccentric amount is 0.25 mm to 0.6 mm and this product can be mounted in the same mounting hole as the Standard Type Cam Followers.

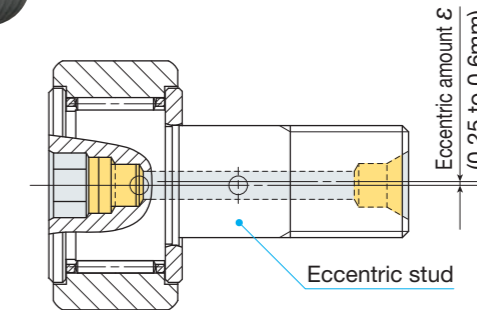
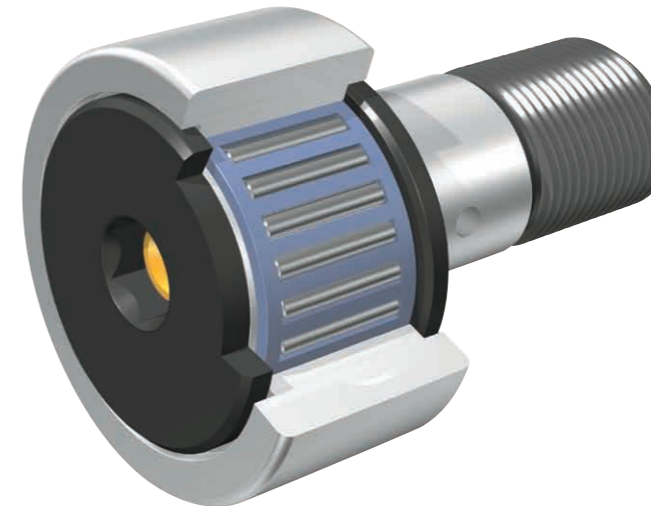

Selectable product specifications

Material type	No symbol	Carbon steel
	F	Stainless steel
Roller guide type	No symbol	Caged
	V	Full complement
Seal structure	No symbol	Shield type
	UU	Sealed type
Shape of outer ring	No symbol	Cylindrical outer ring
	R	Crowned outer ring

To page 43

Eccentric Type Cam Followers

Stud diameter mm
6 to 30

CFE...B

Because the eccentric collar is fixed on the stud, positioning in the radial direction for the mating track surface can be easily performed. The eccentric amount is 0.4 mm to 1.5 mm.

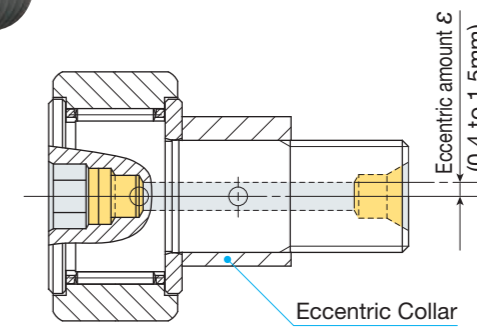
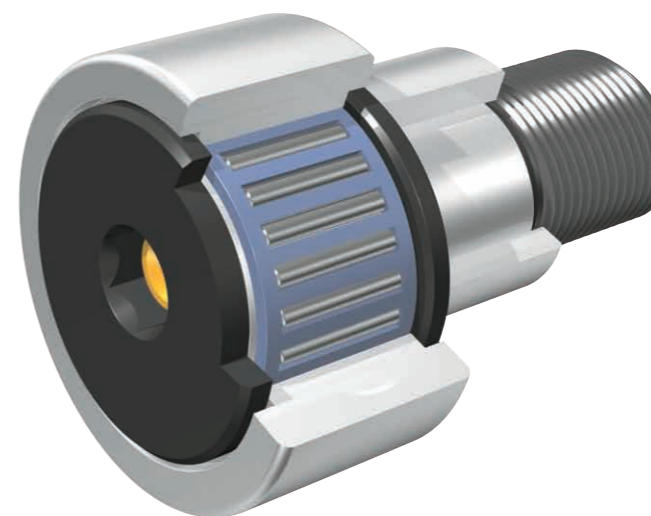

Selectable product specifications

Material type	No symbol	Carbon steel
	F	Stainless steel
Roller guide type	No symbol	Caged
	V	Full complement
Seal structure	No symbol	Shield type
	UU	Sealed type
Shape of outer ring	No symbol	Cylindrical outer ring
	R	Crowned outer ring

To page 45

1 Full product lineup 3

Centralized Lubrication Type Cam Followers

Stud diameter mm
6 to 30

CF-RU1, CF-FU1

A tap hole for centralized piping is made on the head of the stud. This product is most suitable for a position requiring centralized lubrication piping.

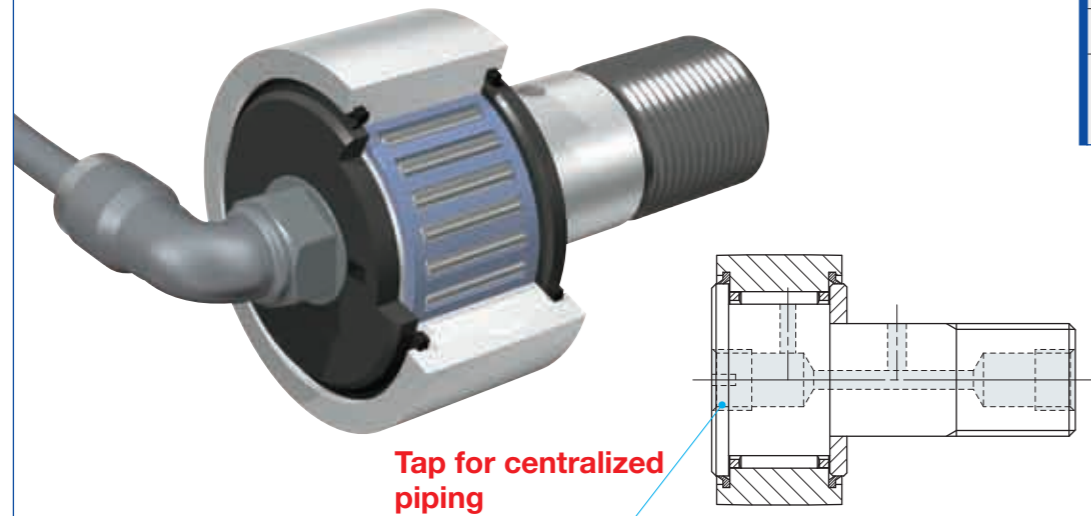

Selectable product specifications

Material type	No symbol	Carbon steel
	F	Stainless steel
Roller guide type	No symbol	Caged
	V	Full complement
Seal structure	No symbol	Shield type
	UU	Sealed type
Shape of outer ring	FU1	Cylindrical outer ring
	RU1	Crowned outer ring

To page 49

Cylindrical Roller Cam Followers

Stud diameter mm
10 to 30

NUCF...B

This product is a full complement bearing in which cylindrical rollers are assembled on the outer ring in a multiple-row form, and can receive a large radial load and a certain level of axial load.

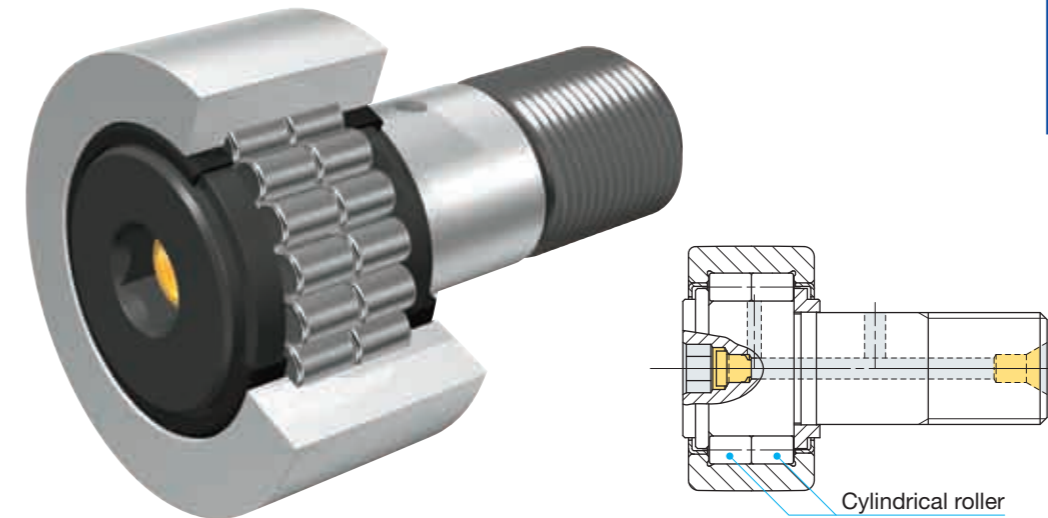

Selectable product specifications

Material type	No symbol	Carbon steel
	F	Stainless steel
Roller guide type	No symbol	Full complement
	V	Shield type
Seal structure	No symbol	Shield type
	UU	Sealed type
Shape of outer ring	No symbol	Cylindrical outer ring
	R	Crowned outer ring

To page 53

Easy Mounting Type Cam Followers

Stud diameter mm
6 to 20

CF-SFU...B

Shouldering is already performed on the stud. This facilitates mounting to fix the shoulder portion with a set screw from the top surface. This product is most suitable for applications such as pallet changer.

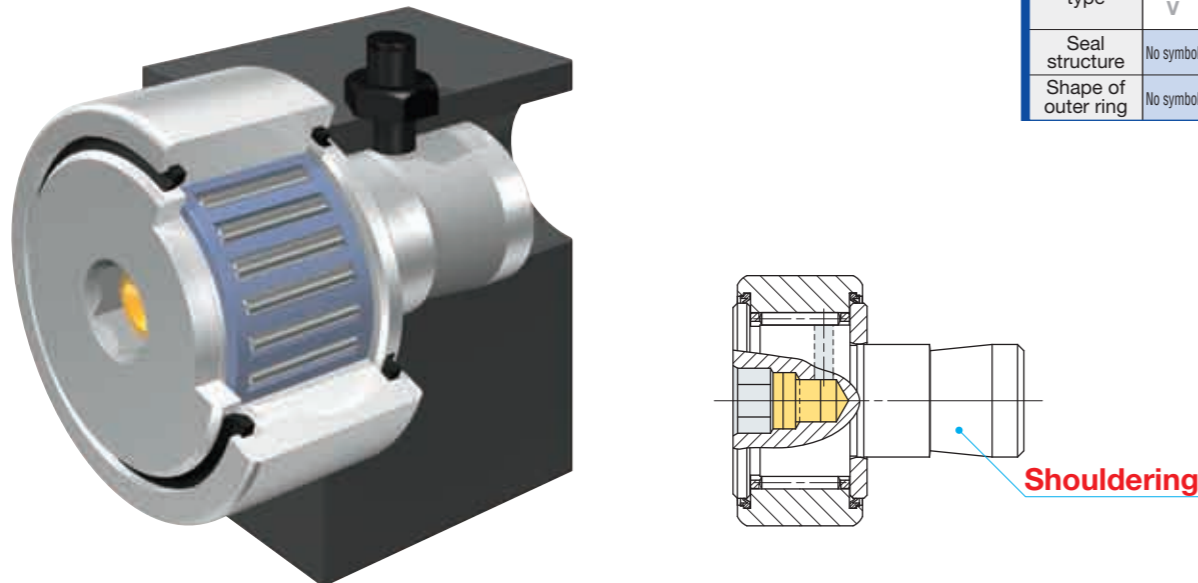

Selectable product specifications

Material type	No symbol	Carbon steel
	F	Stainless steel
Roller guide type	No symbol	Caged
	V	Full complement
Seal structure	No symbol	Shield type
	UU	Sealed type
Shape of outer ring	No symbol	Cylindrical outer ring
	R	Crowned outer ring

To page 51

Inch Series Cam Followers

Stud diameter mm
4.826 to 50.800

CR...B, CRH...B

The two types of Inch Series Cam Followers, CR and CRH, are lined up. The CRH type is applicable to a heavy load with a large rated load and has undergone black oxide film treatment.

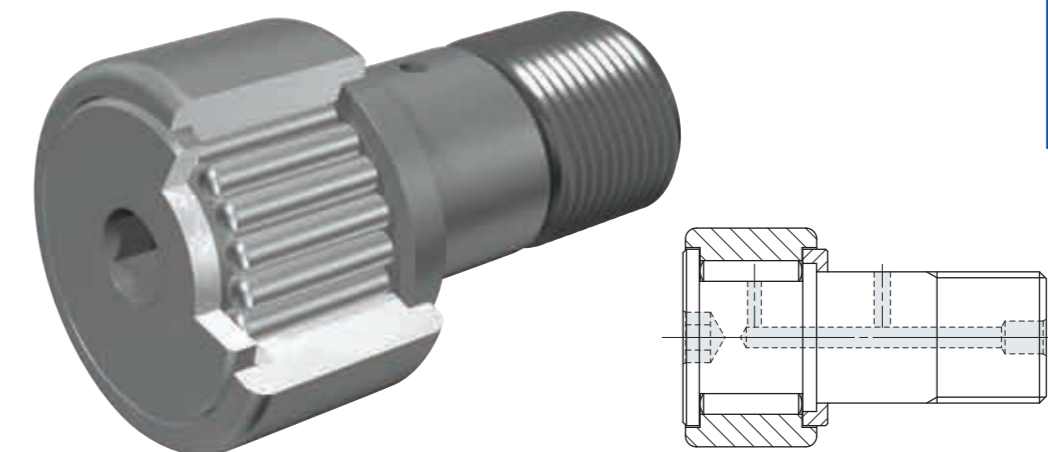

Selectable product specifications

Material type	No symbol	Carbon steel
	F	Stainless steel
Roller guide type	No symbol	Caged
	V	Full complement
Seal structure	No symbol	Shield type
	UU	Sealed type
Shape of outer ring	No symbol	Cylindrical outer ring
	R	Crowned outer ring

To page 55

2 Abundant product specifications that can be selected according to each application

Product system of IKO Hex Head Type Cam Followers

Bearing type	Material type	Roller guide type	Seal section structure	Shape of the external diameter surface of outer ring	Model number	Stud diameter (mm)	Dimension table
Miniature Type Cam Followers CFS	Carbon steel made	Caged	Shield type	Cylindrical outer ring	CFS	2 - 6	Page 31
		Full complement	Shield type	Cylindrical outer ring	CFS...V	2 - 6	Page 31
	Stainless steel made	Caged	Shield type	Cylindrical outer ring	CFS...F	2 - 6	Page 31
		Full complement	Shield type	Cylindrical outer ring	CFS...FV	2 - 6	Page 31
Thrust Disk Type Miniature Cam Followers CFS...W	Carbon steel made	Caged	Shield type	Cylindrical outer ring	CFS...W	2 - 6	Page 33
	Stainless steel made	Caged	Shield type	Cylindrical outer ring	CFS...FW	2 - 6	Page 33
Standard Type Cam Followers CF...B	Carbon steel made	Caged	Shield type	Crowned outer ring	CF...BR	3 - 30	Page 35
			Shield type	Cylindrical outer ring	CF...B	3 - 30	Page 35
			Sealed type	Crowned outer ring	CF...BUUR	3 - 30	Page 35
		Full complement	Shield type	Crowned outer ring	CF...VBR	6 - 30	Page 37
			Shield type	Cylindrical outer ring	CF...VB	6 - 30	Page 37
			Sealed type	Crowned outer ring	CF...VBUUR	6 - 30	Page 37
	Stainless steel made	Caged	Shield type	Crowned outer ring	CF...FBR	3 - 20	Page 35
			Shield type	Cylindrical outer ring	CF...FB	3 - 5	Page 35
			Sealed type	Crowned outer ring	CF...FBUUR	3 - 20	Page 35
		Full complement	Shield type	Crowned outer ring	CF...FVBR	6 - 30	Page 37
			Shield type	Cylindrical outer ring	CF...FVB	6 - 30	Page 37
			Sealed type	Crowned outer ring	CF...FVBUUR	6 - 30	Page 37
Thrust Disk Type Cam Followers CF...WB	Carbon steel made	Caged	Shield type	Crowned outer ring	CF...WBR	3 - 20	Page 39
			Sealed type	Crowned outer ring	CF...WBUUR	3 - 20	Page 39
	Stainless steel made	Caged	Shield type	Crowned outer ring	CF...FWBR	3 - 5	Page 39
			Sealed type	Crowned outer ring	CF...FWBUUR	3 - 5	Page 39
C-Lube Cam Followers CF...WB.../SG	Carbon steel made	Caged	Sealed type	Crowned outer ring	CF...WBUUR/SG	5 - 20	Page 41
Solid Eccentric Stud Type Cam Followers CFES...B	Carbon steel made	Caged	Shield type	Crowned outer ring	CFES...BR	6 - 18	Page 43
				Cylindrical outer ring	CFES...B	6 - 18	Page 43
			Sealed type	Crowned outer ring	CFES...BUUR	6 - 18	Page 43
				Cylindrical outer ring	CFES...BUU	6 - 18	Page 43
Eccentric Type Cam Followers CFE...B	Carbon steel made	Caged	Shield type	Crowned outer ring	CFE...BR	6 - 30	Page 45
				Cylindrical outer ring	CFE...B	6 - 30	Page 45
		Full complement	Shield type	Crowned outer ring	CFE...BUUR	6 - 30	Page 45
				Cylindrical outer ring	CFE...BUU	6 - 30	Page 45
	Stainless steel made	Caged	Shield type	Crowned outer ring	CFE...VBR	6 - 30	Page 47
				Cylindrical outer ring	CFE...VB	6 - 30	Page 47
		Full complement	Shield type	Crowned outer ring	CFE...VBUUR	6 - 30	Page 47
				Cylindrical outer ring	CFE...VBUU	6 - 30	Page 47
Centralized Lubrication Type Cam Followers CF-RU1 CF-FU1	Carbon steel made	Caged	Sealed type	Crowned outer ring	CF-RU1	6 - 30	Page 49
				Cylindrical outer ring	CF-FU1	6 - 30	Page 49
Easy Mounting Type Cam Followers CF-SFU...B	Carbon steel made	Caged	Sealed type	Cylindrical outer ring	CF-SFU...B	6 - 20	Page 51
Cylindrical Roller Cam Followers NUCF...B	Carbon steel made	Full complement	Shield type	Crowned outer ring	NUCF...BR	10 - 30	Page 53

* For the product system of Inch Series Cam Followers, refer to the dimension tables on page 55 to page 66.

Material type

In addition to the carbon steel made type, the stainless steel made type is also available. The stainless steel made type is suitable for an environment and a clean room where oil should be avoided or water is scattered.

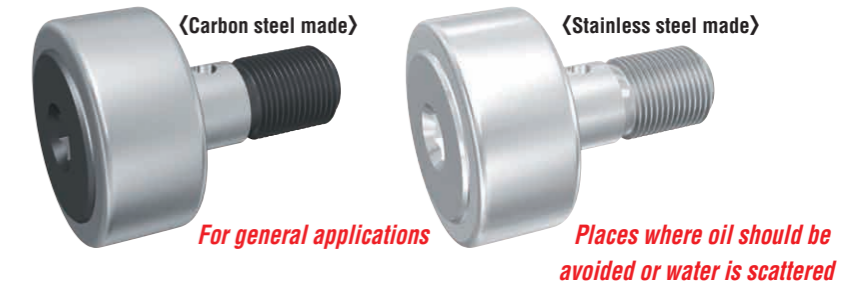

Roller guide type

The caged type has a small coefficient of friction and is suitable for high-speed rotation. The full complement type is suitable for low-speed rotation, rocking motion, and places to which a heavy load is applied.

For a place with a high rotation speed

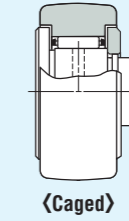

For low-speed rotation or heavy load

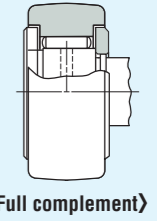

Comparison in maximum rotation speed

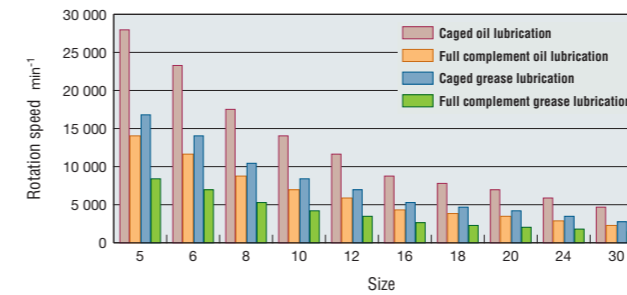

Comparison in dynamic rating load

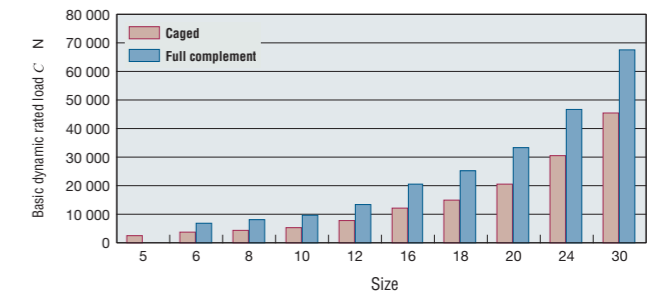

Seal section structure

The shield type reduces the clearance between the outer ring and stud collar section and between the outer ring and end plate, forming a labyrinth. The sealed type consists of seals to prevent foreign substances from entering.

For general applications

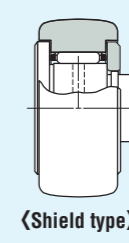

For dust prevention or grease leak prevention

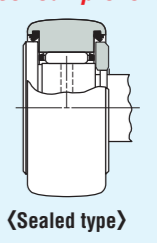

Shape of the external diameter surface of outer ring

The crowned outer ring is effective in relieving an end load due to mounting error. The cylindrical outer ring is suitable for the case where the actual load is large or the track surface is not so hard.

For relieving a mounting error

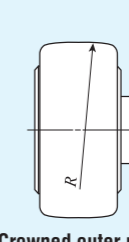

For a large actual load or an insufficient hardness of track surface

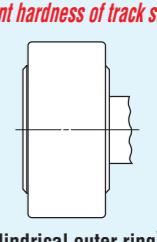

Comparison in track capacity

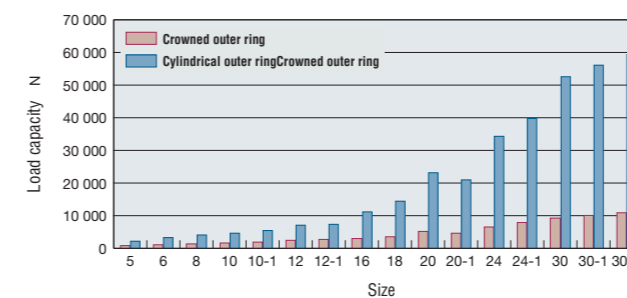

3 Hexagonal head type that can be easily mounted

Tightening can be surely performed on the head of the stud from the hexagon hole with a hex wrench. Mounting can also be performed easily to greatly improve the workability.

Stud tightening can be performed easily and surely with a hex wrench.

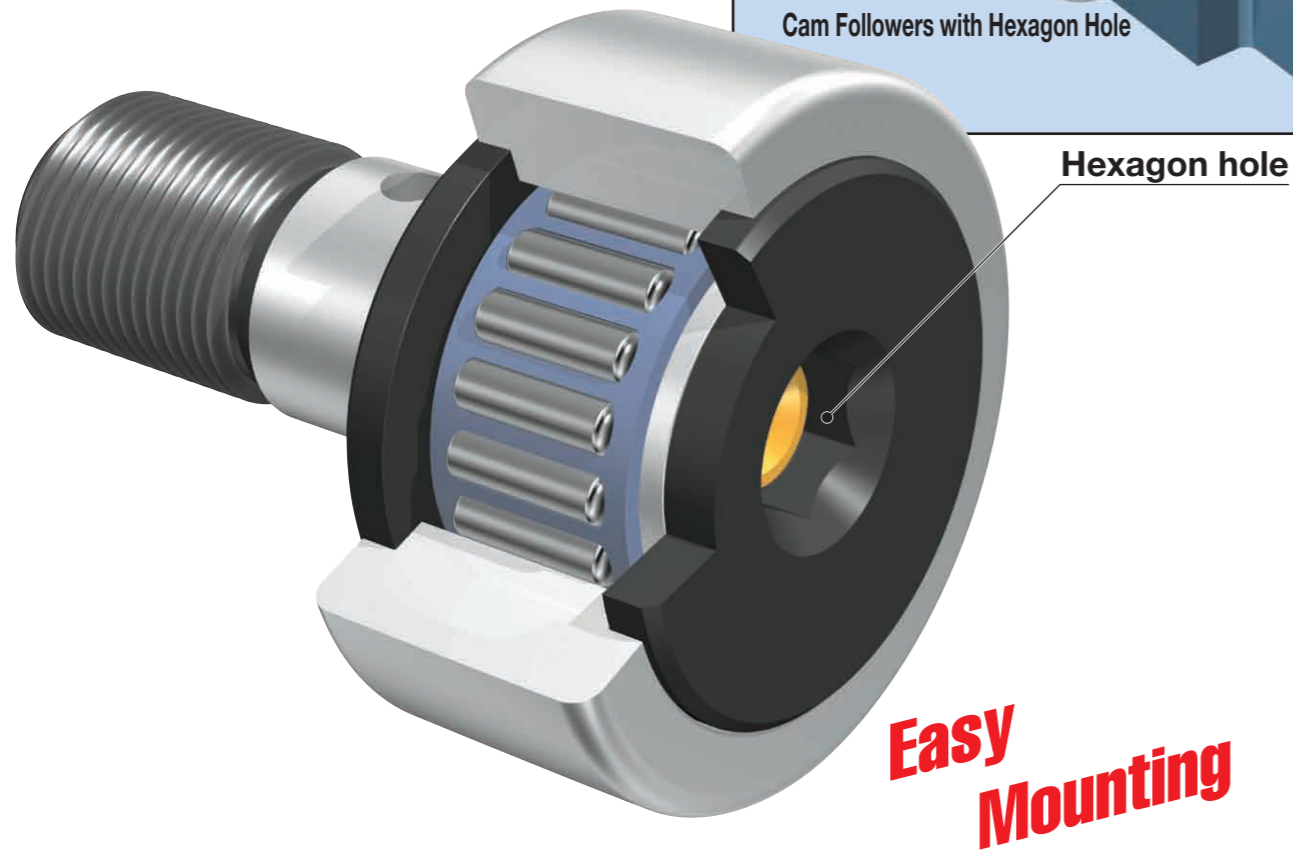
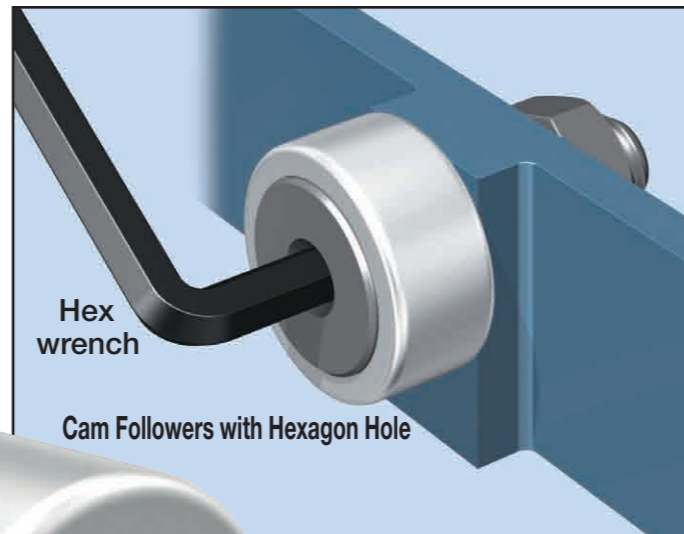

Series to which the hex head type is applicable

Series name	Type	Stud diameter (mm)
Miniature Type Cam Followers	CFS	2 to 6
Thrust Disk Type Miniature Cam Followers	CFS...W	1.4 to 6
Standard Type Cam Followers	CF...B	3 to 30
Thrust Disk Type Cam Followers	CF...WB	3 to 20
C-Lube Cam Followers	CF...WB.../SG	5 to 20
Solid Eccentric Stud Type Cam Followers	CFES...B	6 to 18
Eccentric Type Cam Followers	CFE...B	6 to 30
Easy Mounting Type Cam Followers	CF-SFU...B	6 to 20
Cylindrical Roller Cam Followers	NUCF...B	10 to 30
Inch Series Cam Followers	CR...B, CRH...B	4.826 to 50.800

* Centralized Lubrication Type Cam Followers have a screw driverslot.

4 IKO original structure that permits lubrication from the head of the stud

Original lubrication structure

Cam Followers with Hexagon Hole permit lubrication from the head of the stud.⁽¹⁾



3 Way

Stud dia. 12 to 30mm⁽²⁾

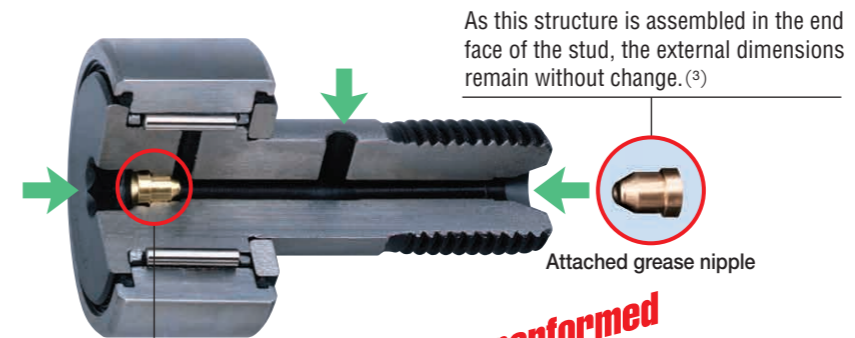

A grease nipple is incorporated in the hexagon hole.

Lubrication can be performed from any of 3 directions with the same external dimensions.

The nipple at the end of the stud is kindly designed so as to avoid any projection.

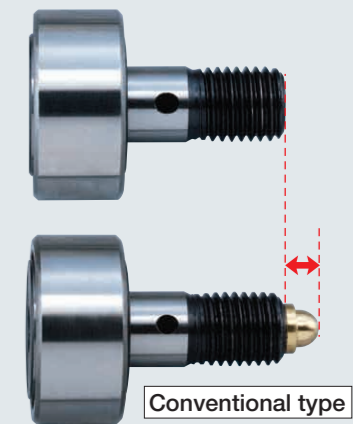

It is also unnecessary to select the cap or grease nipple according to the direction of lubrication.



1 Way

Stud dia. 5 to 10mm

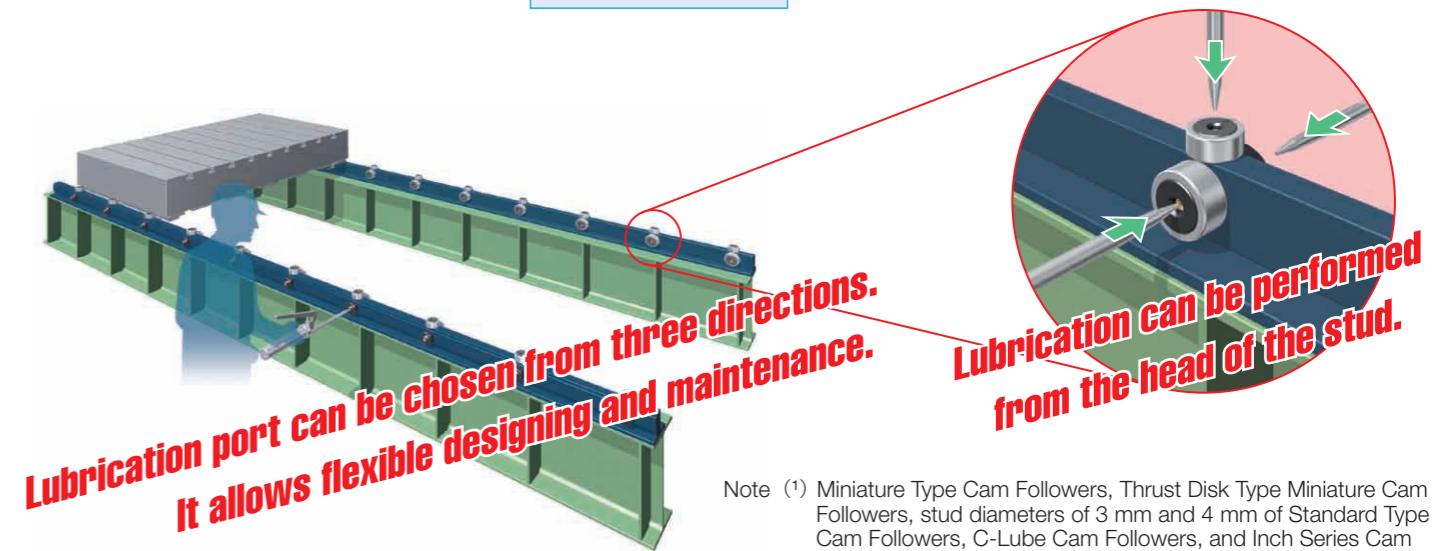
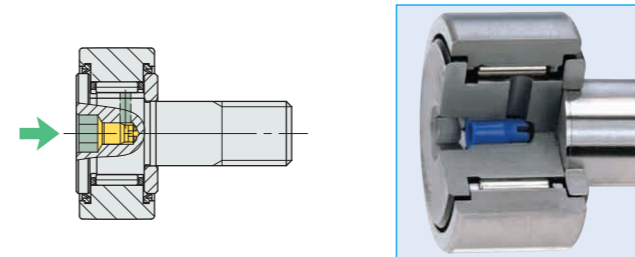

Note (1) Miniature Type Cam Followers, Thrust Disk Type Miniature Cam Followers, stud diameters of 3 mm and 4 mm of Standard Type Cam Followers, C-Lube Cam Followers, and Inch Series Cam Followers are excepted.
 (2) For Eccentric Type Cam Followers, the stud screw diameter G shown in the dimension table is applied. For Easy Mounting Type Cam Followers, the 1-way type is applied to all the sizes.
 (3) The grease nipple on the end face side of the stud is attached as an accessory.

5 C-Lube Unit for Cam Followers based on a new concept

IKO C-Lube Unit for Cam Followers



IKO C-Lube Unit for Cam Followers is a lubricating part to be mounted in Cam Followers. Periodic lubrication is not required because this product supplies the lubricating oil that is indispensable for the external diameter surface of the outer ring and track surface of Cam Followers.



Lubrication onto the track surface is not required for a long time.

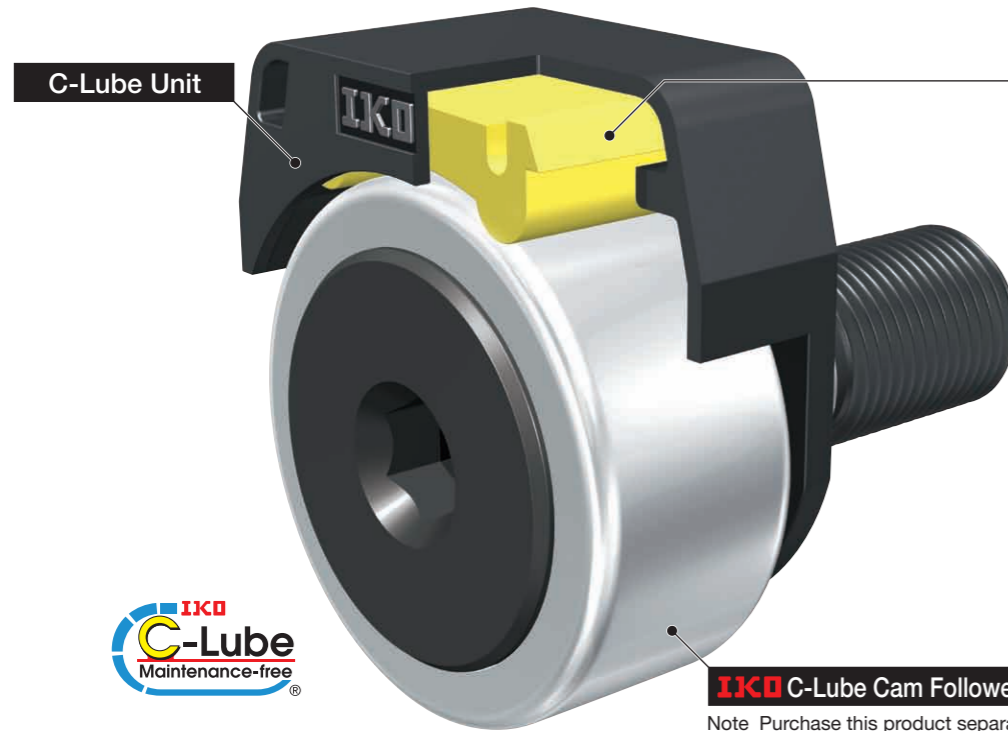

Capillary lubricator

This lubricator is made of the inter-porous sintered resin resulting from sintering and forming fine resin powder, and impregnates a large quantity of lubricating oil by using a capillary phenomenon to be caused in the internal space.

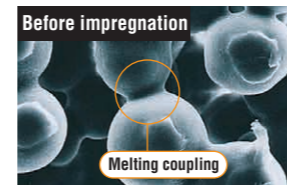

Resin particles are coupled by melting. There are many spaces.

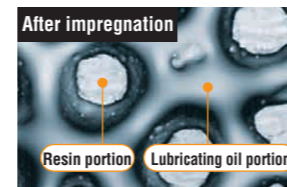

Lubricating oil is kept in the spaces of resin particles.

IKO C-Lube Cam Followers
Note Purchase this product separately from IKO C-Lube Unit.



Don't you have such a difficulty as shown below?

Lubrication maintenance for the track surface is not appropriate.
If a shortage of oil occurs, abrasion will be caused by reddish brown rust. If grease is too much, it will scatter and cause environmental pollution.



Reddish brown abrasion powder is generated.



The circumference is made sticky by grease.

This difficulty can be resolved by C-Lube Unit CL.

Lubricating oil will be continuously supplied for a long time.



This can prevent the ambient environment from being polluted.

Applications of IKO C-Lube Unit for Cam Followers CL

A long-time maintenance-free status of the track surface has been achieved.

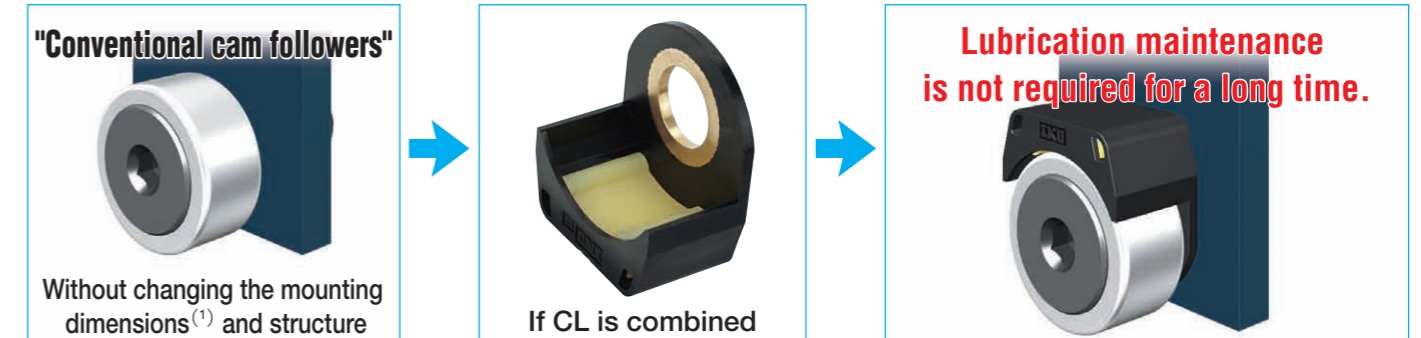

Note(1) Cam Followers are offset several mm in the axial direction according to the thickness of the CL resin cover.

The performance of CL has been substantiated by endurance test result.

《Endurance test》

Test conditions(2)	
Sample	CL12, C-Lube Unit for Cam Followers CF12 WBUUR/SG, C-Lube Cam Followers
Lubricating condition	C-Lube Unit only without prepacked grease
Maximum speed	2000 mm/s
Stroke length	300 mm
Track surface specifications	Material SKD11 Hardness HRC58 or more Surface roughness Rz: 6.3 μm or less
Ambient temperature	Room temperature

Note (2) Endurance is checked by using the ground track surface. For operating in the other conditions, the customer is requested to make a check with its own machine.

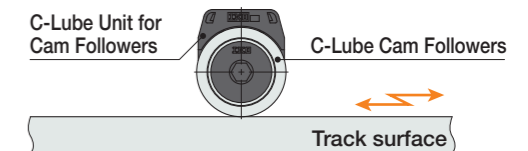
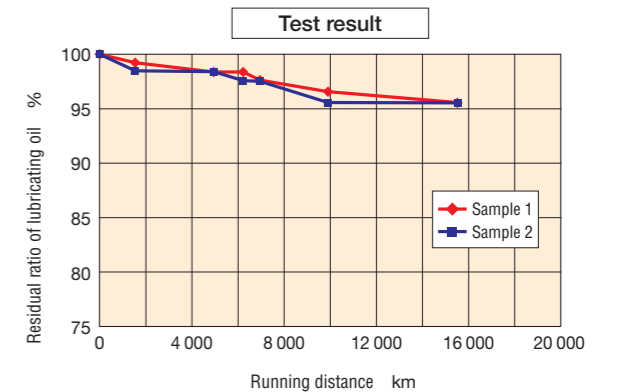

A combination with IKO C-Lube Cam Followers is the most desirable.

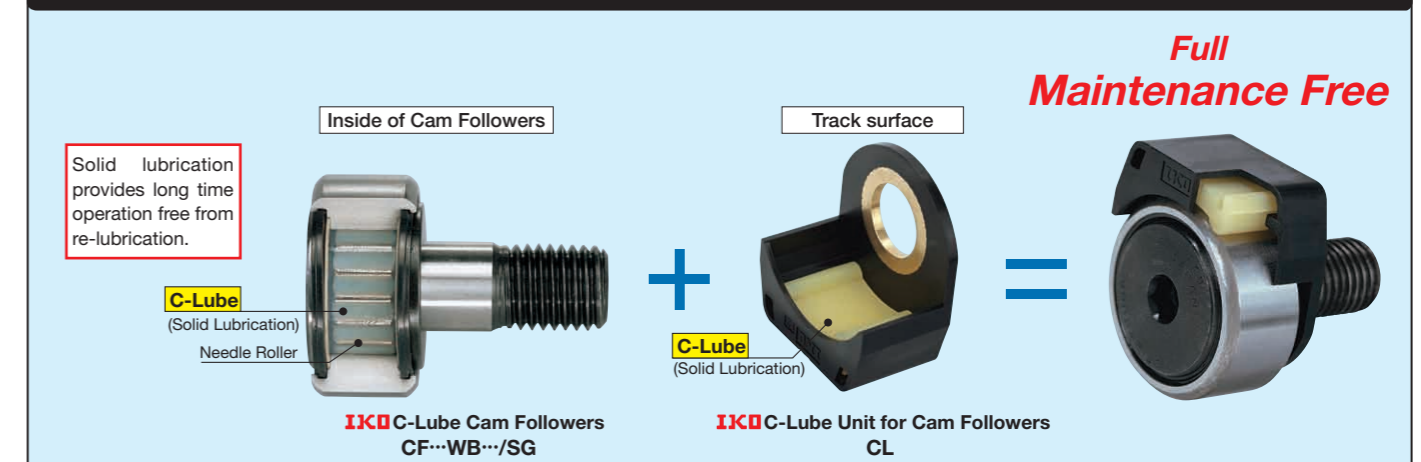

Remark C-Lube Unit can be combined with Standard Type Cam Followers, Thrust Disk Type Cam Followers, C-Lube Cam Followers, Centralized Lubrication Type Cam Followers, or Cylindrical Roller Cam Followers.

Identification Number

Some examples of the identification number of Cam Followers are shown below. For applicable material symbol, roller guide method, seal structure and shape of outer ring outside surface, refer dimension table of each series.

Examples of identification number

Example 1	CFS	3	F	V				P6
Example 2	CF	10		V	B	UU	R	
Example 3	CF	5	F	W	B	UU	R	
Example 4	CF	8		W	B	UU	R	/SG

Model number	
CFS	Miniature Type Cam Follower
CFS...W	Thrust Disk Type Miniature Cam Follower
CF...B	Standard Type Cam Follower
CF...WB	Thrust Disk Type Cam Follower
CF...WB.../SG	C-Lube Cam Follower
CFES...B	Solid Eccentric Stud Type Cam Follower
CFE...B	Eccentric Type Cam Follower
CF-RU1	Centralized Lubrication Type Cam Follower (With crowned outer ring)
CF-FU1	Centralized Lubrication Type Cam Follower (With cylindrical outer ring)
CF-SFU...B	Easy Mounting Type Cam Follower
NUCF...B	Cylindrical Roller Cam Follower
CR...B	Inch series Cam Follower(With Hexagon socket)
CR	Inch series Cam Follower(With Screw driverslot)
CRH...B	Inch series Cam Follower(With Hexagon socket)
CRH	Inch series Cam Follower(With Screw driverslot)

Size	
The value indicates a stud diameter. (unit: mm)	
In the inch series, the outside diameter of the outer ring in units of 1/16 inch is indicated.	

Material	
No symbol	High carbon steel made
F	Stainless steel made

Roller guide method ⁽¹⁾	
No symbol	With cage type
V	Full complement type

Note⁽¹⁾ Cylindrical Roller Cam Follower is Full complement type with "No Symbol".

Seal structure ⁽¹⁾	
No symbol	Shield type
UU	Sealed type

Note⁽¹⁾ Centralized Lubrication Type and Easy Mounting Type are sealed Type with "No Symbol".

Shape of outer ring outside surface	
R	With crowned outer ring
No symbol	With cylindrical outer ring

Classification symbol		
No symbol	Class 0	
P6	Class 6	Applicable to Miniature CFS series
P5	Class 5	
P4	Class 4	

Load Rating and Life

Basic dynamic load rating C

The basic dynamic load rating is defined as the constant radial load that 90% of a group of identical Cam Followers can be operated 1,000,000 revolutions individually under the same conditions free from any material damage caused by rolling fatigue.

Basic static load rating C_0

The basic static load rating is the static radial load constant in direction and magnitude that gives the contact stress shown at the center of the contact area of the rolling element and the raceway receiving the maximum load.

Bearing life

Basic rating life is calculated as following formula.

$$L_{10} = \left(\frac{C}{P_r}\right)^{10/3} \dots \dots \dots (1)$$

where, L_{10} : Basic rating life, 10^6 rev.
 C : Basic dynamic load rating, N
 P_r : Dynamic equivalent radial load, N

Accordingly, when the rotational speed per minute is given, the basic rating life is represented as the total service hours according to the following equations:

$$L_h = \frac{10^6 L_{10}}{60n} \dots \dots \dots (2)$$

where, L_h : Basic rating life represented by service hours, h
 n : Rotation speed, min^{-1}

Static Safety factor

The static safety factor f_s is defined as in the following equation and its general values are shown in Table 1.

$$f_s = \frac{C_0}{P_0} \dots \dots \dots (3)$$

where, C_0 : Basic static load rating, N
 P_0 : Static equivalent load, N

Table 1 Static safety factor

Operating conditions of the bearing	f_s
When high rotational accuracy is required	≥ 3
For ordinary operation conditions	≥ 1.5
For ordinary operation conditions not requiring very smooth rotation When there is almost no rotation	≥ 1

Load factor

It is not unusual for the actual Cam Followers loads to exceed the calculated loads, due to vibration and shocks produced when operating the machine. The actual bearing load is obtained by multiplying the calculated load by the load factor shown in Table 2.

Table 2 Load Factor

Operating conditions	f_w
Smooth operation without shocks	1 ~ 1.2
Ordinary operation	1.2 ~ 1.5
Operation subjected to vibration and shocks	1.5 ~ 3

Maximum Allowable Static Load

The applicable load on Cam Followers is, in some cases, limited by the bending strength and shear strength of the stud and the strength of the outer ring instead of the load rating of the needle roller bearing. Therefore, the maximum allowable static load that is limited by these strengths is specified.

Accuracy

The accuracy of Cam Followers is shown in Table 3, Table 4.1, Table 4.2 and Table 4.3. Cam Followers with special accuracy are also available. When they are required, please contact IKO.

Table 3 Tolerances

unit: μm

Dimensions and symbols	Series	Metric CF series ⁽¹⁾		Inch series	
	Miniature CFS series	Crowned outer ring	Cylindrical outer ring	Crowned outer ring	Cylindrical outer ring
Outside dia. of outer ring D	See Table 4.1	0 - 50	See Table 4.2	0 - 50	See Table 4.3
Stud dia. d_1	h6	h7		+ 25 0	
Width of outer ring C	0 - 120	0 - 120		0 - 130	

Note⁽¹⁾ Also applicable to the entire Cam Followers except Miniature series and Inch series.

Table 4.1 Tolerances and allowable values of outer rings (Miniature CFS series)

unit: μm

ΔD_{mp} Single plane mean outside dia. deviation								K_{ca} Radial runout of assembled bearing outer ring (Max.)			
Class 0		Class 6		Class 5		Class 4		Class 0	Class 6	Class 5	Class 4
High	Low	High	Low	High	Low	High	Low				
0	-8	0	-7	0	-5	0	-4	15	8	5	4

Table 4.2 Tolerances and allowable values of outer rings (Metric CF series cylindrical outer rings)

unit: μm

D Nominal outside dia. of outer ring mm		ΔD_{mp} Single plane mean outside dia. deviation		V_{Dsp} Outside dia. variation in a single radial plane (Max.)	V_{Dmp} Mean outside dia. variation (Max.)	K_{ca} Radial runout of assembled bearing outer ring (Max.)
Over	Incl.	High	Low			
6	18	0	- 8	10	6	15
18	30	0	- 9	12	7	15
30	50	0	- 11	14	8	20
50	80	0	- 13	16	10	25
80	120	0	- 15	19	11	35

Table 4.3 Tolerances and allowable values of outer rings (Inch series cylindrical outer ring)

unit: μm

D Nominal outside dia. of outer ring mm		ΔD_{mp} Single plane mean outside dia. deviation		V_{Dsp} Outside dia. variation in a single radial plane (Max.)	V_{Dmp} Mean outside dia. variation (Max.)	K_{ca} Radial runout of assembled bearing outer ring (Max.)
Over	Incl.	High	Low			
6	18	0	- 25	10	6	15
18	30			12	7	15
30	50			14	8	20
50	80			16	10	25
80	120			19	11	35

Clearance

The radial internal clearances of Cam Followers are shown in Table 5.

Table 5 Radial internal clearance

unit: μm

Identification number				Radial internal clearance	
Miniature CFS series CFS, CFS...W	Metric CF series ⁽¹⁾	Cylindrical Roller Cam Followers	Inch series	Min.	Max.
CFS1.4 ~ CFS5	CF 3B ~ CF 5B	—	CR 8,CR 8-1,CRH 8-1,CRH 9	3	17
CFS6	CF 6B	—	CR10,GR10-1,CRH10-1,CRH11	5	20
—	CF 8B ~ CF12-1B	—	CR12 ~ CR22,CRH12 ~ CRH22	5	25
—	CF16B ~ CF20-1B	—	CR24 ~ CR36,CRH24 ~ CRH36	10	30
—	CF24B ~ CF30-2B	—	CR48,CRH40 ~ CRH56	10	40
—	—	—	CRH64	15	50
—	—	NUCF10 B ~ NUCF24 B	—	20	45
—	—	NUCF24-1B ~ NUCF30-2B	—	25	50

Note⁽¹⁾ Only representative types are shown in the table, but this table is applicable to the entire Cam Followers except Miniature series, Cylindrical Roller Cam Followers, and Inch series.

Fit

Tables 6 and 7 show recommended tolerances of mounting holes for Cam Follower studs. Since the Cam Follower is supported in a cantilever position, the mounting hole diameter should be prepared without play between the stud and the hole especially when heavy shock loads are applied.

Table 6 Recommended fit

Type	Tolerance class of mounting hole for stud
Miniature CFS series	H6
Metric CF series ⁽¹⁾	H7
Inch series	F7

Note⁽¹⁾ Only representative types are shown in the table, but this table is applicable to the entire Cam Followers except Miniature series and Inch series.

Table 7 Dimensional tolerances of mounting hole

unit: μm

Nominal outside dia. of stud mm		F7		H6		H7	
Over	Incl.	Over	Incl.	Over	Incl.	Over	Incl.
—	3	+ 16	+ 6	+ 6	0	+ 10	0
3	6	+ 22	+ 10	+ 8	0	+ 12	0
6	10	+ 28	+ 13	+ 9	0	+ 15	0
10	18	+ 34	+ 16	+ 11	0	+ 18	0
18	30	+ 41	+ 20	+ 13	0	+ 21	0
30	50	+ 50	+ 25	+ 16	0	+ 25	0

Track Capacity

Track capacity is defined as a load which can be continuously applied on a Cam Follower placed on a steel track surface without causing any deformation or indentation on the track surface when the outer ring of the Cam Follower makes contact with the mating track surface (plane). The track capacities shown in Tables 8.1, 8.2 and 8.3 are applicable when the hardness of the mating track surface is 40HRC (Tensile strength 1250N/mm²). When the hardness of the mating track surface differs from 40HRC, the track capacity is obtained by multiplying the value by the track capacity factor shown in Table 9.

If lubrication between the outer ring and the mating track surface is insufficient, seizure and/or wear may occur depending on the application. Therefore, attention must be paid to lubrication and surface roughness of the mating track especially for high-speed rotations such as cam mechanisms. For lubrication between the outer ring and the mating track surface, C-Lube Unit for Cam Followers is recommended.

Table 8.1 Track Capacity for Miniature Type Cam Follower CFS, CFS...W

Identification number with cylindrical outer ring	Track capacity
CFS1.4	128
CFS2	220
CFS2.5	298
CFS3	485
CFS4	799
CFS5	1 210
CFS6	1 680

Table 8.2 Track capacity for Metric series Cam Follower⁽¹⁾

Identification number With crowned outer ring	Track capacity	Identification number With cylindrical outer ring	Track capacity
CF 3 BR	542	CF 3 B	1 360
CF 4 BR	712	CF 4 B	1 790
CF 5 BR	794	CF 5 B	2 210
CF 6 BR	1 040	CF 6 B	3 400
CF 8 BR	1 330	CF 8 B	4 040
CF10 BR	1 610	CF10 B	4 680
CF10-1BR	2 030	CF10-1B	5 530
CF12 BR	2 470	CF12 B	7 010
CF12-1BR	2 710	CF12-1B	7 480
CF16 BR	3 060	CF16 B	11 200
CF18 BR	3 660	CF18 B	14 500
CF20 BR	5 190	CF20 B	23 200
CF20-1BR	4 530	CF20-1B	21 000
CF24 BR	6 580	CF24 B	34 300
CF24-1BR	8 020	CF24-1B	39 800
CF30 BR	9 220	CF30 B	52 700
CF30-1BR	9 990	CF30-1B	56 000
CF30-2BR	10 800	CF30-2B	59 300

Note⁽¹⁾ This table is applicable to the entire Cam Followers except Miniature series and Inch series.

Table 8.3 Track capacity for Inch series Cam Followers

Identification number With crowned outer ring	Track capacity	Identification number With cylindrical outer ring	Track capacity	Identification number With crowned outer ring	Track capacity	Identification number With cylindrical outer ring	Track capacity
CR 8 R	770	CR 8	2 140	—	—	—	—
CR 8-1R	770	CR 8-1	2 360	CRH 8-1R	401	CRH 8-1	2 360
—	—	—	—	CRH 9 R	469	CRH 9	2 650
CR10 R	1 030	CR10	3 210	—	—	—	—
CR10-1R	1 030	CR10-1	3 480	CRH10-1R	579	CRH10-1	3 480
—	—	—	—	CRH11 R	658	CRH11	3 830
CR12 R	1 340	CR12	4 500	CRH12 R	853	CRH12	4 500
CR14 R	1 630	CR14	5 250	CRH14 R	1 050	CRH14	5 250
CR16 R	1 970	CR16	7 280	CRH16 R	1 420	CRH16	7 280
CR18 R	2 300	CR18	7 710	CRH18 R	1 660	CRH18	7 710
CR20 R	2 680	CR20	10 700	CRH20 R	2 160	CRH20	10 700
CR22 R	3 050	CR22	11 800	CRH22 R	2 450	CRH22	11 800
CR24 R	3 410	CR24	15 400	CRH24 R	3 410	CRH24	15 400
CR26 R	3 820	CR26	16 700	CRH26 R	3 820	CRH26	16 700
CR28 R	4 210	CR28	21 000	CRH28 R	4 210	CRH28	21 000
CR30 R	4 610	CR30	22 500	CRH30 R	4 610	CRH30	22 500
CR32 R	5 050	CR32	30 900	CRH32 R	5 690	CRH32	30 900
CR36 R	5 900	CR36	34 700	CRH36 R	6 640	CRH36	34 700
—	—	—	—	CRH40 R	8 970	CRH40	45 000
—	—	—	—	CRH44 R	10 200	CRH44	49 500
—	—	CR48	64 300	CRH48 R	11 400	CRH48	64 300
—	—	—	—	CRH52 R	12 700	CRH52	69 600
—	—	—	—	CRH56 R	14 100	CRH56	87 000
—	—	—	—	CRH64 R	16 800	CRH64	113 000

Table 9 Track capacity factor

Hardness HRC	Tensile strength N/mm ²	Track capacity factor	
		With crowned outer ring	With cylindrical outer ring
20	760	0.22	0.37
25	840	0.31	0.46
30	950	0.45	0.58
35	1 080	0.65	0.75
38	1 180	0.85	0.89
40	1 250	1.00	1.00
42	1 340	1.23	1.15
44	1 435	1.52	1.32
46	1 530	1.85	1.51
48	1 635	2.27	1.73
50	1 760	2.80	1.99
52	1 880	3.46	2.29
54	2 015	4.21	2.61
56	2 150	5.13	2.97
58	2 290	6.26	3.39

Allowable Rotational Speed

The allowable rotational speed of Cam Followers is affected by mounting and operating conditions. For reference, Table 10 shows d_1n values when only pure radial loads are applied. Considering that axial loads also act under actual operating conditions, the recommended d_1n value is 1/10 of the value shown in the table.

In case of C-Lube Cam Follower or with C-Lube unit, d_1n value is 10000 or less.

In case of C-Lube Cam Follower or with C-Lube unit with axial loads, d_1n value is 10000 or 1/10 of the values in Table 10, whichever smaller.

Table 10 d_1n values of Cam Followers⁽¹⁾

Type	Lubricant	
	Grease	Oil
Caged type	84 000	140 000
Full complement type	42 000	70 000
Cylindrical Roller Cam Followers	66 000	110 000

Note⁽¹⁾ d_1n value = $d_1 \times n$
 where, d_1 : Stud diameter mm
 n : Rotational speed rpm

Lubrication

Grease-prepacked Cam Followers are shown in Table 11. The lubricating grease prepacked in these bearings is ALVANIA GREASE S2 (SHELL).

For Cam Followers without prepacked grease, grease should be packed through the oil hole in the stud for use. If they are used without grease, wear of rolling contact surfaces may take place, leading to a short bearing life.

Table 11 Grease-prepacked Cam Followers

Series	Type	With cage		Full complement type
		Shield type	Sealed type	
Miniature series	CFS	○	—	○
	CFS...W	○	—	○
Metric series	CF...B	○	○	○
	CF...WB			
	CFES...B	×	—	○
	CFE...B	×	—	○
C-Lube Cam Followers	CF...WB.../SG ⁽²⁾	—	×	—
Centralized Lubrication Type Cam Followers	CF - RU1 CF - FU1	—	○	—
Easy Mounting Type Cam Followers	CF - SFU...B	—	○	—
Cylindrical Roller Cam Followers	NUCF...B	—	—	○
Inch series	CR...B	○	○	○
	CR	○	○	○
Inch series	CRH...B	—	—	○
	CRH	—	—	○

Notes⁽¹⁾ For Eccentric Type Cam Followers (CFE), thread diameter G shown in the table of dimensions is applicable.

⁽²⁾ This Cam Follower incorporates C-Lube which includes a large amount of lubricating oil.

Oil Hole

The position of oil hole is shown in Table 12. Re-greasing cannot be made for models without a oil hole.

Grease should be supplied gently with a straight type grease gun as specified by JIS B 9808 :1991, which is applied carefully to the nipple head from the front.

When NPT type grease nipple on Table 18 or NPB type grease nipple on Table 16 is attached on stud end, it is possible to lubricate with a general grease gun from NPT or NPB type grease nipple without lubrication nozzle on Table 13.

Some type of Cam Followers that oil hole is not prepared on Table 12 cannot be lubricated.

Table 12 Position of oil hole

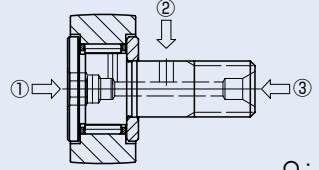

○ : Oil hole is prepared.

Series Size of stud dia. d_1 (1) mm	Position of oil hole		
	① Stud head	② Stud outside surface	③ Stud end
Miniature Type Cam Follower CFS	-	-	-
Thrust Disk Type Miniature Cam Follower CFS...W	-	-	-
Standard Type Cam Follower CF...B			
Thrust Disk Type Cam Follower CF...WB	$d_1 \leq 4$	-	-
Solid Eccentric Stud Type Cam Follower CFES...B	$5 \leq d_1 \leq 10$	○ ⁽²⁾	-
Eccentric Type Cam Follower CFE...B			
Cylindrical Roller Cam Follower NUCF...B	$10 < d_1$	○ ⁽³⁾	○
C-Lube Cam Follower CF...WB.../SG	-	-	-
Centralized Lubrication Type Cam Follower ⁽⁴⁾ CF - RU1, CF - FU1	$d_1 \leq 12$	○	-
	$12 < d_1$	○	○
Easy Mounting Type Cam Follower CF - SFU...B	$d_1 \leq 10$	○ ⁽²⁾	-
	$10 < d_1$	○ ⁽⁵⁾	-
Inch series Cam Follower CR...B (With Hexagon socket)	$d_1 \leq 6.35$	-	-
	$6.35 < d_1$	-	○
Inch series Cam Follower CR (With Screw driverslot)	$d_1 \leq 6.35$	○	-
	$6.35 < d_1$	○	○
Inch series Cam Follower CRH...B (With Hexagon socket)	$d_1 \leq 7.938$	-	-
	$7.938 < d_1$	-	○
Inch series Cam Follower CRH (With Screw driverslot)	$d_1 \leq 7.938$	○	-
	$7.938 < d_1$	○	○

Notes⁽¹⁾ In case of Eccentric Type Cam Followers (CFE), thread diameter G shown in the table of dimensions is applicable in place of stud dia. and the oil hole on the outer surface of the stud cannot be used for lubrication.

⁽²⁾ Re-lubrication can be made from the re-greasing fitting that is inserted into the hexagon hole.

⁽³⁾ Grease nipple is incorporated in the hexagon hole. Re-greasing can be made from the stud head and the stud end by press fitting a supplied grease nipple into the stud end.

⁽⁴⁾ Tapped holes for oil connectors are provided at the stud end and hole of the head.

⁽⁵⁾ Re-greasing can be made from the grease nipple in the hexagon hole.

Table 13 Type and Dimension of Lubrication Nozzles

Type	Dimension	Applicable grease nipple and re-greasing fitting
A-5126T		NPF4-1 ⁽¹⁾ NPF6-1 ⁽¹⁾ Re-greasing fitting ⁽¹⁾
A-5120R		NPF4-1 ⁽¹⁾ NPF6-1 ⁽¹⁾
B-5120R		NPF4-1 ⁽¹⁾ NPF6-1 ⁽¹⁾
A-5120V		NPF4-1 ⁽¹⁾ NPF6-1 ⁽¹⁾
A-5240V		NPT4-1 NPT6-1 NPB2 NPB3 NPB3-1 NPB4
B-5120V		NPT4-1 NPT6-1 NPB2 NPB3 NPB3-1 NPB4
B-5240V		NPT4-1 NPT6-1 NPB2 NPB3 NPB3-1 NPB4

Note⁽¹⁾ HSP-3(Yamada Corporation) can be used for them.
Remark The above nozzles can be attached on the standard grease gun shown below.
If required, please consult to IKO with type of lubrication Nozzle.

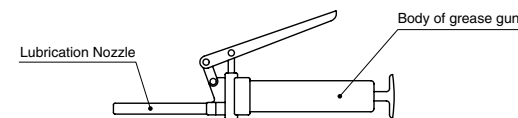

Accessories

Cam Follower accessories are shown in Table 14. Grease nipple dimensions are shown in Table 15. Dimensions of plug for unused oil hole and dimensions of plug inserter are shown in Table 17.

Table 14 Accessories

○ : Attached

Series Size of stud dia. d_1 (1) mm	Accessories	Grease nipple	Plug	Nut	Spring washer
Miniature Type Cam Follower CFS		-	-	○	-
Thrust Disk Type Miniature Cam Follower CFS...W		-	-	○	-
Standard Type Cam Follower CF...B					
Thrust Disk Type Cam Follower CF...WB	$d_1 \leq 10$	-	-	○	-
Solid Eccentric Stud Type Cam Follower CFES...B	$12 \leq d_1$	○	-	○	-
Cylindrical Roller Cam Follower NUCF...B		-	-	○	-
C-Lube Cam Follower CF...WB.../SG		-	-	○	-
Eccentric Type Cam Follower CFE...B	$d_1 \leq 10$	-	-	○	○
	$12 \leq d_1$	○	-	○	○
Centralized Lubrication Type Cam Follower CF - RU1, CF - FU1		-	-	○	-
Easy Mounting Type Cam Follower CF - SFU...B		-	-	-	-
Inch series Cam Follower CR...B (With Hexagon socket)	$d_1 \leq 6.35$	-	-	○	-
	$9.525 \leq d_1$	○	○	○	-
Inch series Cam Follower CR (With Screw driverslot)		○	○	○	-
Inch series Cam Follower CRH...B (With Hexagon socket)	$d_1 \leq 7.938$	-	-	○	-
	$11.112 \leq d_1$	○	○	○	-
Inch series Cam Follower CRH (With Screw driverslot)		○	○	○	-

Note⁽¹⁾ For Eccentric Type Cam Follower CFE, thread diameter G is applied.

Table 15 Dimensions of grease nipple for standard Cam Follower⁽¹⁾

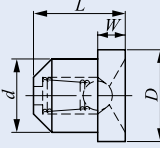

Code number	Dimensions mm				Size of stud dia. d_1 (2) mm
	d	D	L	W	
NPF4-1	4	5	5	1.5	12~16
NPF6-1	6	7	8	2	18~30

Notes⁽¹⁾ This table is applicable except Inch series.

⁽²⁾ For Eccentric Type Cam Follower CFE, thread diameter G is applied.

Table 16 Dimensions of Grease nipple for Inch series

Code number	Dimensions mm						Applicable Cam Followers
	d	D	D_1	L	L_1	W	
NPB2	3.18	7.5	6	9	5.5	1.5	CR8~CR10-1, CRH8-1~CRH11
NPB3	4.76	7.5	6	10	5.5	1.5	CR12~CR22, CRH12~CRH22
NPB3-1	4.76	7.5	6	12.5	5.5	1.55	CR24~CR36, CRH24~CRH44
NPB4	6.35	8.5	6	13	6	2	CR48, CRH48~CRH64

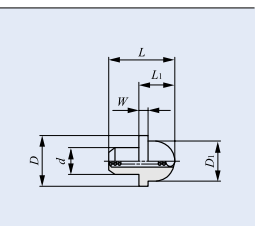
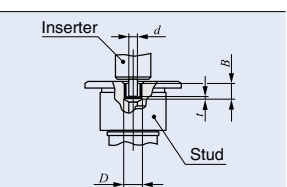

Table 17 Dimensions of plug for Inch series

Code number	Dimensions of plug mm			Dimension of inserter mm	Applicable Cam Followers
	D	t	B		
USB2F	3.18	0.3	3.3	2.3	CR8~CR10-1
USB3F	4.76	0.4	4.3	3.7	CR12~CR36, CRH12~CRH44
USB4F	6.35	0.5	4.8	5.2	CR48, CRH48~CRH64



Optional Specification

NPT type grease nipple in Table 18 can be attached instead of standard accessories by direction. With NPT type grease nipple, it is possible to lubricate with a general grease gun (JIS B 9808 :1991) without lubrication nozzle on Table 13. If required, please order with supplemental code, "/NP" at the end of identification number.

Example of Identification Number.

CF 12 BUUR / NP

Table 18 Dimension of NPT type grease nipple.

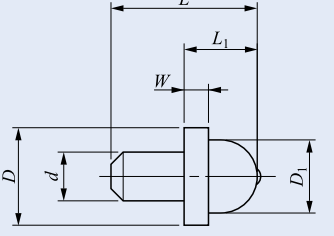

Code number	Dimension of grease nipple mm						Size of stud dia. d_1 (1) mm
	d	D	D_1	L	L_1	W	
NPT4-1	4	8	6	12	6	2	12~16
NPT6-1	6	8	6	14	8	4	18~30

Note⁽¹⁾ For Eccentric Type Cam Follower CFE, thread diameter G is applied.

Table 19 Dimension of assembled NPT type grease nipple.

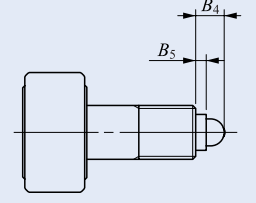

Code number	Dimension mm		Size of stud dia. d_1 (1) mm
	B_4	B_5	
NPT4-1	6	2	12~16
NPT6-1	6	2	18~30

Note⁽¹⁾ For Eccentric Type Cam Follower CFE, thread diameter G is applied.

Operating Temperature Range

The operating temperature range for IKO Cam Followers is $-20^{\circ}\text{C} \sim +120^{\circ}\text{C}$. Please pay attention as the types shown in table 20 have different range.

Table 20 Restricted Operating Temperature Range

Type Size of stud dia. d_1 mm	Type	With cage	
		Shield type	Sealed type
Miniature Type Cam Followers CFS Thrust Disk Type Miniature Cam Followers CFS...W	$d_1 = 2$	-20°C~	-
		110°C ⁽¹⁾	-
Standard Type Cam Followers CF...B Thrust Disk Type Cam Followers CF...WB	$d_1 = 3, 4$	-20°C~	-20°C~
		110°C ⁽¹⁾	80°C
Stainless Steel Standard Type Cam Followers CF...FB Stainless Steel Thrust Disk Type Cam Followers CF...FWB	$3 \leq d_1 \leq 5$	-20°C~	-20°C~
		110°C ⁽¹⁾	80°C
C-Lube Cam Followers CF...WB.../SG	$5 \leq d_1 \leq 20$	-	-15°C~ 80°C ⁽²⁾

Notes⁽¹⁾ 100 degree C in continuous operation.
⁽²⁾ 60 degree C or lower is recommended in long time.

Mounting

① Make the center axis of the mounting hole perpendicular to the moving direction of the Cam Follower and match the side shoulder accurately with the seating surface indicated by dimension f in the table of dimensions. (See Fig. 1.) Then, fix the Cam Follower with the nut. Do not hit the flange head of the Cam Follower directly with a hammer, etc. This may lead to a bearing failure such as irregular rotation or cracking.

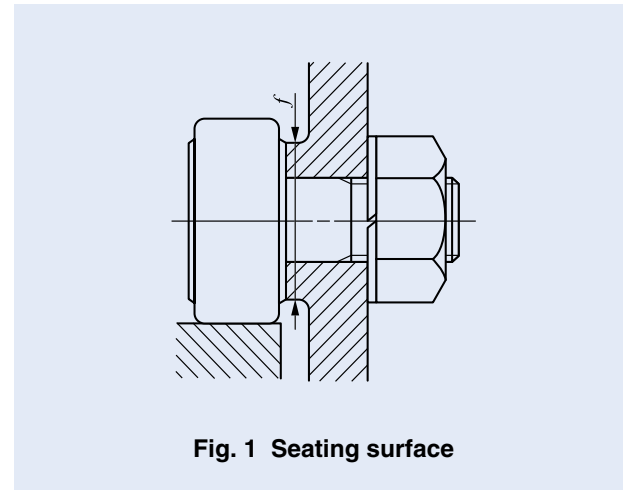

Fig. 1 Seating surface

② The IKO mark on the flange head of the stud indicates the position of the oil hole on the raceway. Avoid locating the oil hole within the loading zone. This may lead to a short bearing life. (See Fig. 2.) The hole located in the middle part of the stud perpendicular to the stud center axis is used for greasing or locking.

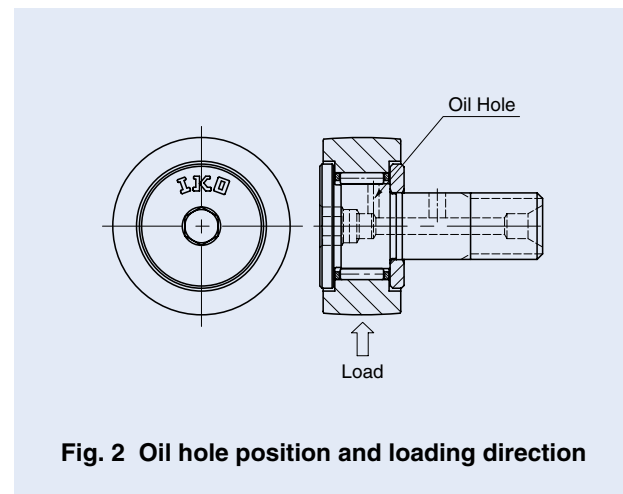

Fig. 2 Oil hole position and loading direction

③ When tightening the nut, the tightening torque should not exceed the values shown in the table of dimensions. If the tightening torque is too large, it is possible that the threaded portion of the stud will be broken. When there is a possibility of loosening, a special nut such as a lock nut, spring washer, or self-locking nut should be used.

④ Solid Eccentric Stud Type Cam Followers and Eccentric Type Cam Followers, are mounted in reference position where IKO mark on the head of stud is located as Fig. 3. The outer ring position can be adjusted appropriately by turning the stud with a screwdriver or hexagon bar wrench using the screwdriver slot or hexagon hole of the stud head. The stud is fixed with a nut and a spring washer, etc. The tightening torque should not exceed the values of maximum tightening torque shown in the table of dimensions.

When shock loads are applied and the adjusted eccentricity has to be ensured, it is recommended to make holes in the housing, stud and eccentric collar, and fix the stud with a dowel pin as shown in Fig. 4. However, when the stud diameter is less than 8 mm (Eccentric collar diameter 11 mm), it is difficult to make a hole in the stud because the stud is through-hardened.

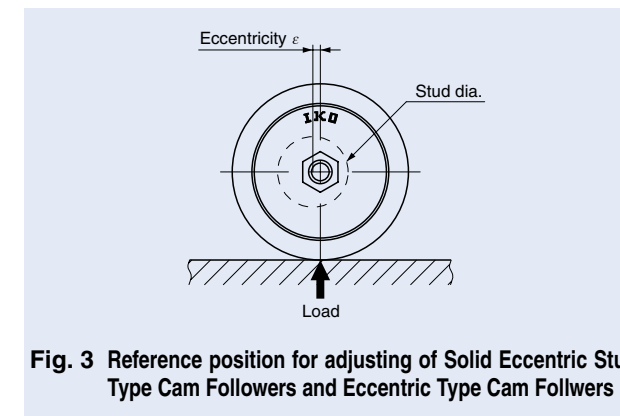

Fig. 3 Reference position for adjusting of Solid Eccentric Stud Type Cam Followers and Eccentric Type Cam Followers

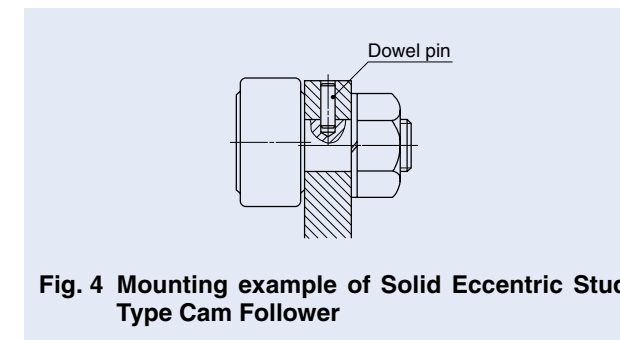

Fig. 4 Mounting example of Solid Eccentric Stud Type Cam Follower

⑤ In case of Eccentric Type Cam Followers (CFE), the length of the mounting hole should be more than 0.5 mm longer than the dimension B_3 (Eccentric collar width) shown in the table of dimensions. (See Fig. 5.)

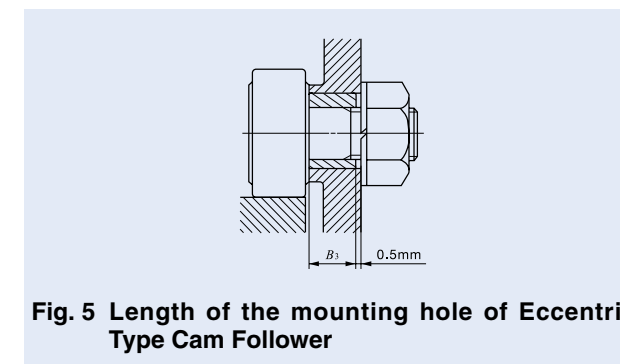

Fig. 5 Length of the mounting hole of Eccentric Type Cam Follower

⑥ Eccentric collar is available for Inch series Cam Followers. Cam Followers with Eccentric collars, CRE are also available. If required, please consult with IKO.

Table 21 Eccentric collars for Inch series Cam Followers

Identical number of collar	Outer diameter of collar d_e	Length of collar B_3	Eccentricity ϵ	Stud dia. d	Applicable Cam Followers
EB 8	6.350 (1/4)	6.350 (1/4)	0.250	4.826	CR 8 (V)(B)(R)(UU)
EB10	9.525 (3/8)	9.525 (3/8)	0.380	6.350 (1/4)	CR10 (V)(B)(R)(UU)
EB12	12.700 (1/2)	12.700 (1/2)	0.380	9.525 (3/8)	CR12 (V)(B)(R)(UU)
EB16	15.875 (5/8)	15.875 (5/8)	0.760	11.112 (7/16)	CR16 (V)(B)(R)(UU)
EB20	17.450	17.450	0.760	12.700 (1/2)	CR20 (V)(B)(R)(UU)
EB24	22.225 (7/8)	22.225 (7/8)	0.760	15.875 (5/8)	CR24 (V)(B)(R)(UU)
EB28	25.400 (1)	25.400 (1)	0.760	19.050 (3/4)	CR28 (V)(B)(R)(UU)
EB32	30.150	30.150	0.760	22.225 (7/8)	CR32 (V)(B)(R)(UU)
EB48	44.450 (1 3/4)	44.450 (1 3/4)	1.520	31.750 (1 1/4)	CR48 VUU

unit: mm

⑦ For mounting Easy Mounting Type Cam Followers, it is recommended to fix the fixing screw from the upper side to the stepped portion of the stud. (See Fig. 6.)

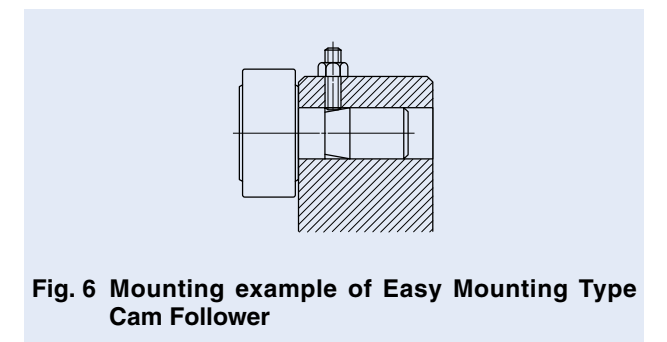

Fig. 6 Mounting example of Easy Mounting Type Cam Follower

Precaution For Use

① Do not wash C-Lube Cam Follower with organic solvent and/or white kerosene, which have the ability of removing fat nor leave them in contact with the above agents.

② To ensure normal rotation of the C-Lube Cam Follower, apply a load of 1% or over of the dynamic load rating at use.

C-Lube Unit for Cam Followers

Structure of C-Lube Unit for Cam Followers

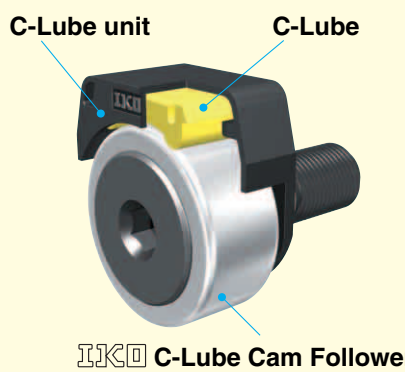

C-Lube unit **C-Lube**

IKO C-Lube Cam Follower

Magnified photos of C-Lube

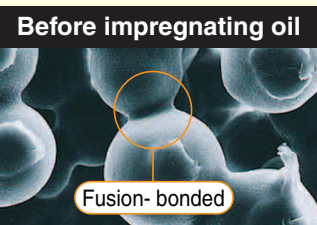

Before impregnating oil

Fusion-bonded

Resin particles are strongly fusion bonded.

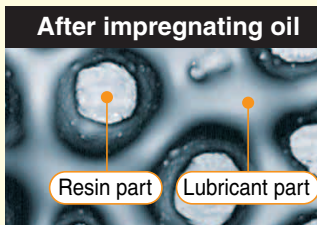

After impregnating oil

Resin part Lubricant part

Lubricant is retained in cavities amongst resin particles.

Identification number

The identification number example of **IKO** C-Lube Unit is shown below.

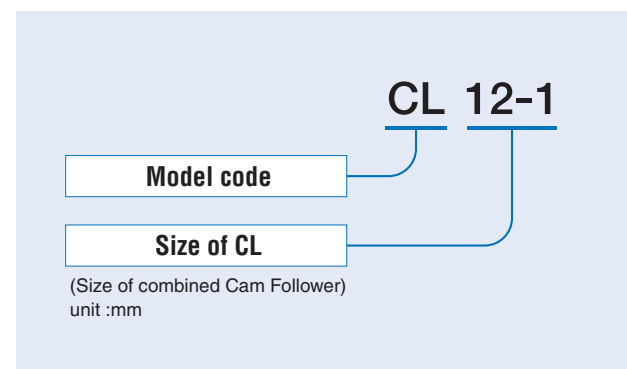

Mounting

① Set the C-Lube Unit perpendicularly to the center axis of Cam Follower and fix together with Cam Follower by tightening nut.

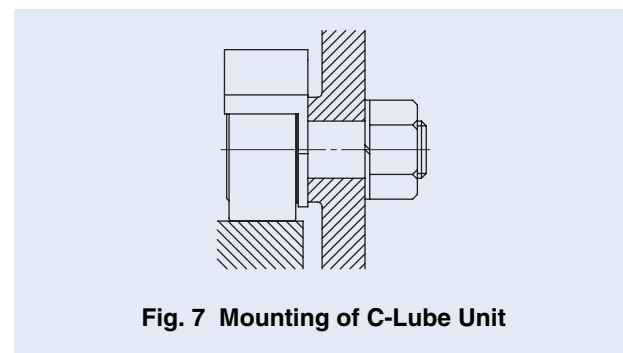

Allowable rotation speed

The rotation speed of **IKO** Cam Follower with C-Lube Unit should not exceeded $d_1 n = 10,000$ for reference.

$$d_1 n = d_1 \times n$$

d_1 : Stud diameter of Cam Follower, mm
 n : Rotational speed, rpm

Minimum rotational angle

Lubricating oil is supplied to the whole external diameter surface of the outer ring. Accordingly, use the product in a condition in which the outer ring makes one or more turns.

Operating temperature

Allowable operating temperature range of **IKO** Cam Follower with C-Lube Unit is -15 to 80°C.

② Position of C-Lube Unit is adjustable. C-Lube Unit must be positioned avoiding loading direction.

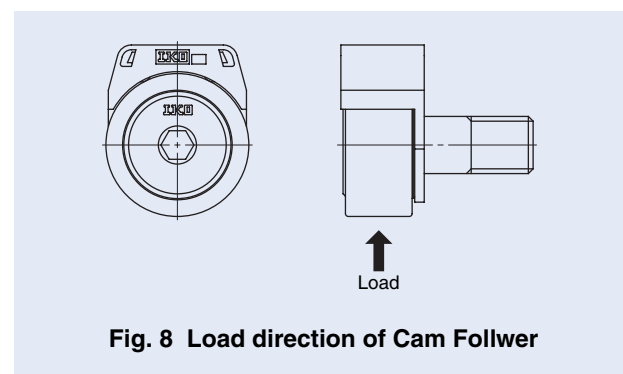

③ When tightening the nut, the tightening torque should not be exceeded the value maximum tightening torque on dimension table.

④ In case loosening of the nut is predicted due to vibration, using lock nut, spring washer and other special washer are recommended.

Table 22 Dimensions of C-Lube Unit for Cam Followers

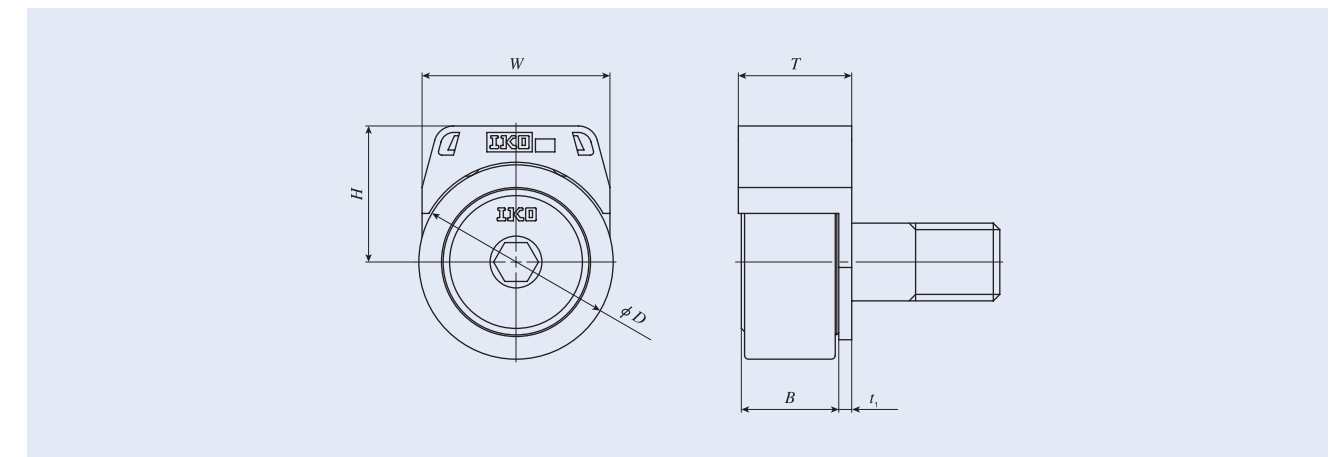

Model number	Boundary Dimensions mm				Applicable Cam Followers		
	<i>W</i>	<i>H</i>	<i>T</i>	<i>t₁</i>	Model number ⁽¹⁾	Boundary Dimensions mm	
						<i>D</i>	<i>B_{max}</i>
CL 5	12.4	10.7	12.1	1.5	CF 5 B	13	10
CL 6	15.4	12.6	14	1.5	CF 6 B	16	12.2
CL 8	18.4	14.2	14	1.5	CF 8 B	19	12.2
CL 10	21	17	15.5	2	CF 10 B	22	13.2
CL 10-1	21	19.2	15.5	2	CF 10-1 B	26	13.2
CL 12	29	21	17.5	2	CF 12 B	30	15.2
CL 12-1	29	22	17.5	2	CF 12-1 B	32	15.2
CL 16	33.8	27.4	23.4	2.5	CF 16 B	35	19.6
CL 18	38.8	30.4	25.4	2.5	CF 18 B	40	21.6
CL 20	45.8	38.4	29.9	3	CF 20 B	52	25.6
CL 20-1	45.8	35.4	29.9	3	CF 20-1 B	47	25.6

Note⁽¹⁾ Only representative types shown in the table, but also applicable to the same size of Metric series, with thrust disk type, centralized lubrication type, C-Lube Cam Followers and Cylindrical Roller Cam Followers. Combine with C-Lube Cam Followers is strongly recommended for full maintenance free.

Precaution for use

- ① The maximum allowable load on **IKO** Cam Follower with C-Lube Unit is, 80% of the maximum allowable load of the needle bearing.
C-Lube Unit may be damaged and influenced to the smooth rotation and lubricating performance by excessive load.
- ② After assembling C-Lube Unit and Cam Followers in the machine, please confirm that C-Lube unit provides oil correctly to the track surface before actual operation.
- ③ Do not use in the environment which contamination of liquid and/or harmful foreign matter are expected.
- ④ Do not wash with organic solvent and/or white kerosene, which have the ability of removing fat nor leave them in contact with the above agents.
- ⑤ To ensure normal rotation of the Cam Follower, apply a load of 1% or over of the dynamic load rating at use.
Also, the outer ring needs to be rotate over a revolution to supply lubricant on entire outer diameter surface.
- ⑥ Replace with new C-Lube Unit when inside oil finishes completely. Re-lubrication is not possible.
- ⑦ Do not apply a load onto the C-Lube Unit directly.

IKO Miniature Type Cam Followers With Hexagon Hole

Selectable product specifications

Material	No symbol	Carbon steel
	F	Stainless steel
Roller guide type	No symbol	Caged
	V	Full complement
Seal structure	No symbol	Shield type
	UU	Sealed type
Shape of outer ring	No symbol	Cylindrical outer ring
	R	Crowned outer ring

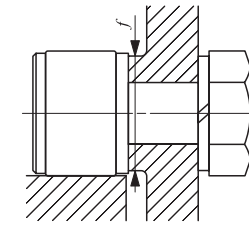
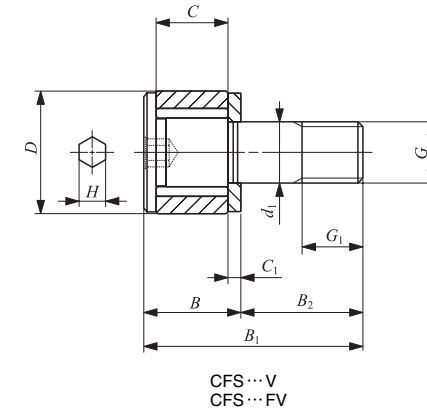
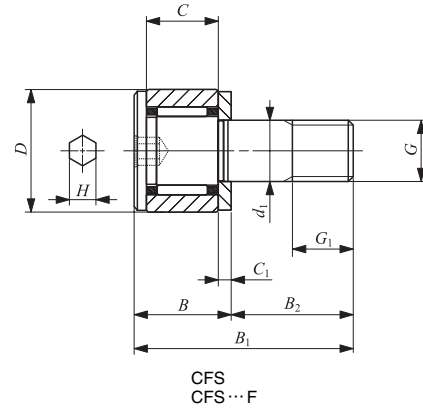

Stud dia. mm	Identification number		Mass (Ref.) g	Boundary dimensions mm					
	With cage	Full complement		D	C	d ₁	G	G ₁	B
2	CFS 2 —	— CFS 2 V	0.6	4.5	2.5	2	M2 × 0.4	2	4
	CFS 2 F —	— CFS 2 FV							
2.5	CFS 2.5 —	— CFS 2.5 V	1	5	3	2.5	M2.5 × 0.45	2.5	4.5
	CFS 2.5 F —	— CFS 2.5 FV							
3	CFS 3 —	— CFS 3 V	2	6	4	3	M3 × 0.5	3	5.5
	CFS 3 F —	— CFS 3 FV							
4	CFS 4 —	— CFS 4 V	4	8	5	4	M4 × 0.7	4	7
	CFS 4 F —	— CFS 4 FV							
5	CFS 5 —	— CFS 5 V	7	10	6	5	M5 × 0.8	5	8
	CFS 5 F —	— CFS 5 FV							
6	CFS 6 —	— CFS 6 V	13	12	7	6	M6 × 1	6	9.5
	CFS 6 F —	— CFS 6 FV							

- Remarks1. No oil hole is provided.
2. Provided with prepacked grease.
3. A nut is supplied with the stud.

B ₁	B ₂	C ₁	H	Mounting dimension f Min. mm	Maximum tightening torque N-cm	Basic load rating		Maximum allowable static load N
						Basic dynamic load rating C N	Basic static load rating C ₀ N	
8	4	0.7	0.9	4.3	9.1	288	202	202
						768	734	229
9.5	5	0.7	0.9	4.8	18.7	230	161	161
						614	587	229
11.5	6	0.7	1.3	5.8	33.5	428	351	351
						1 000	1 080	360
15	8	1.0	1.5	7.7	77.7	342	281	281
						800	862	360
18	10	1.0	2	9.6	158	629	611	484
						1 420	1 790	484
21.5	12	1.2	2.5	11.6	268	504	488	484
						1 140	1 430	484
15	8	1.0	1.5	7.7	77.7	1 120	1 120	919
						2 370	3 000	919
18	10	1.0	2	9.6	158	897	894	894
						1 900	2 400	919
21.5	12	1.2	2.5	11.6	268	1 570	1 850	1 570
						3 180	4 700	1 570
21.5	12	1.2	2.5	11.6	268	1 250	1 480	1 480
						2 540	3 760	1 570
21.5	12	1.2	2.5	11.6	268	2 090	2 200	2 150
						4 610	6 250	2 150
21.5	12	1.2	2.5	11.6	268	1 670	1 760	1 760
						3 690	5 000	2 150

IKO Thrust Disk Type Miniature Cam Followers With Hexagon Hole

Selectable product specifications

Material	No symbol	Carbon steel
	F	Stainless steel
Roller guide type	No symbol	Caged
	V	Full complement
Seal structure	No symbol	Shield type
	UU	Sealed type
Shape of outer ring	No symbol	Cylindrical outer ring
	R	Crowned outer ring

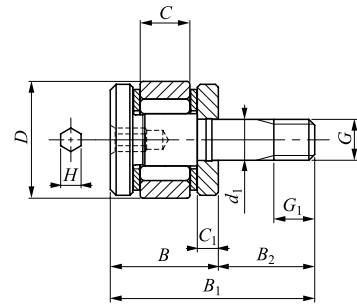
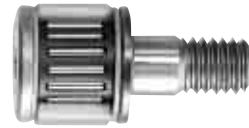

CFS1.4 WV

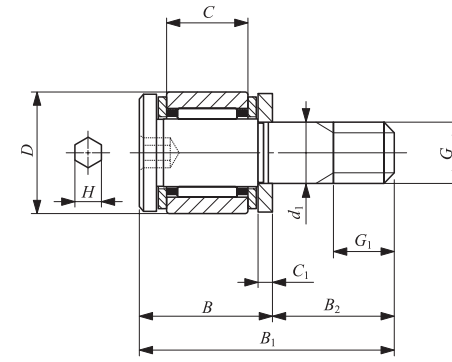

CFS... W
CFS...FW

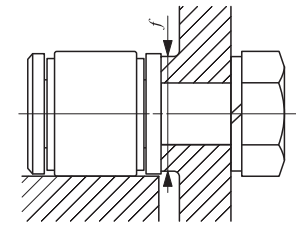

Stud dia. mm	Identification number		Mass (Ref.) g	Boundary dimensions mm					
	With cage	Full complement		D	C	d ₁	G	G ₁	B
1.4	—	CFS 1.4 WV	0.35	4	1.7	1.4	M1.4 × 0.3	1.4	3.7
2	CFS 2 W	—	0.6	4.5	2.5	2	M2 × 0.4	2	4.5
	CFS 2 FW	—							
2.5	CFS 2.5 W	—	1	5	3	2.5	M2.5 × 0.45	2.5	5
	CFS 2.5 FW	—							
3	CFS 3 W	—	2	6	4	3	M3 × 0.5	3	6.5
	CFS 3 FW	—							
4	CFS 4 W	—	4	8	5	4	M4 × 0.7	4	8
	CFS 4 FW	—							
5	CFS 5 W	—	7	10	6	5	M5 × 0.8	5	9
	CFS 5 FW	—							
6	CFS 6 W	—	13	12	7	6	M6 × 1	6	10.5
	CFS 6 FW	—							

- Remarks1. No oil hole is provided.
2. Provided with prepacked grease.
3. A nut is supplied with the stud.

B ₁	B ₂	C ₁	H	Mounting dimension f Min. mm	Maximum tightening torque N-cm	Basic load rating		Maximum allowable static load N
						Basic dynamic load rating C N	Basic static load rating C ₀ N	
7	3.3	0.7	0.9	3.8	3.0	481	385	105
8.5	4	0.7	0.9	4.3	9.1	288	202	194
						230	161	161
10	5	0.7	0.9	4.8	18.7	428	351	313
						342	281	281
12.5	6	0.7	1.3	5.8	33.5	629	611	399
						504	488	399
16	8	1.0	1.5	7.7	77.7	1120	1120	785
						897	894	785
19	10	1.0	2	9.6	158	1570	1850	1370
						1250	1480	1370
22.5	12	1.2	2.5	11.6	268	2090	2200	1920
						1670	1760	1760

IKO Standard Type Cam Followers With Cage/With Hexagon Hole

Selectable product specifications

Material	No symbol	Carbon steel
	F	Stainless steel
Roller guide type	No symbol	Caged
	V	Full complement
Seal structure	No symbol	Shield type
	UU	Sealed type
Shape of outer ring	No symbol	Cylindrical outer ring
	R	Crowned outer ring

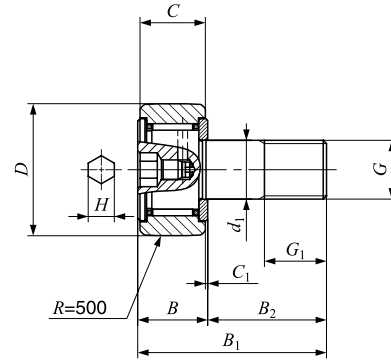

CF...(F)BR
Stud dia d_1 3 to 10mm

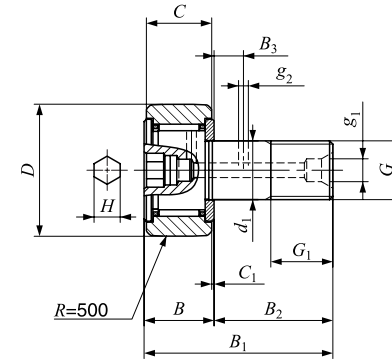

CF...(F)BR
Stud dia d_1 12 to 30mm

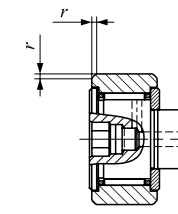

CF...(F)B

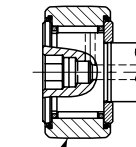

CF...(F)BUUR

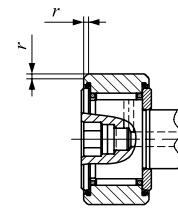

CF...(F)BUU

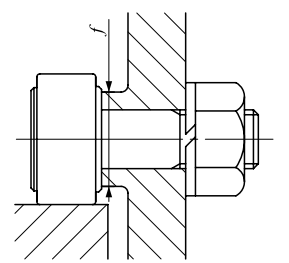

Stud dia. mm	Identification number				Mass (Ref.) g	Boundary dimensions mm				
	Shield type		Sealed type			D	C	d_1	G	G_1
	With crowned outer ring	With cylindrical outer ring	With crowned outer ring	With cylindrical outer ring						
3	CF 3 BR	CF 3 B	CF 3 BUUR	CF 3 BUU	4.3	10	7	3	M 3 × 0.5	5
	CF 3 FBR	CF 3 FB	CF 3 FBUUR	CF 3 FBUU	4.3	10	7	3	M 3 × 0.5	5
4	CF 4 BR	CF 4 B	CF 4 BUUR	CF 4 BUU	7.4	12	8	4	M 4 × 0.7	6
	CF 4 FBR	CF 4 FB	CF 4 FBUUR	CF 4 FBUU	7.4	12	8	4	M 4 × 0.7	6
5	CF 5 BR	CF 5 B	CF 5 BUUR	CF 5 BUU	10.3	13	9	5	M 5 × 0.8	7.5
	CF 5 FBR	CF 5 FB	CF 5 FBUUR	CF 5 FBUU	10.3	13	9	5	M 5 × 0.8	7.5
6	CF 6 BR	CF 6 B	CF 6 BUUR	CF 6 BUU	18.5	16	11	6	M 6 × 1	8
	CF 6 FBR	—	CF 6 FBUUR	—	18.5	16	11	6	M 6 × 1	8
8	CF 8 BR	CF 8 B	CF 8 BUUR	CF 8 BUU	28.5	19	11	8	M 8 × 1.25	10
	CF 8 BRM	CF 8 BM	CF 8 BUURM	CF 8 BUUM	28.5	19	11	8	M 8 × 1	10
	CF 8 FBR	—	CF 8 FBUUR	—	28.5	19	11	8	M 8 × 1.25	10
10	CF 10 BR	CF 10 B	CF 10 BUUR	CF 10 BUU	45	22	12	10	M10 × 1.25	12
	CF 10 BRM	CF 10 BM	CF 10 BUURM	CF 10 BUUM	45	22	12	10	M10 × 1	12
	CF 10 FBR	—	CF 10 FBUUR	—	45	22	12	10	M10 × 1.25	12
	CF 10-1 BR	CF 10-1 B	CF 10-1 BUUR	CF 10-1 BUU	60	26	12	10	M10 × 1.25	12
	CF 10-1 BRM	CF 10-1 BM	CF 10-1 BUURM	CF 10-1 BUUM	60	26	12	10	M10 × 1	12
12	CF 12 BR	CF 12 B	CF 12 BUUR	CF 12 BUU	95	30	14	12	M12 × 1.5	13
	CF 12 FBR	—	CF 12 FBUUR	—	95	30	14	12	M12 × 1.5	13
	CF 12-1 BR	CF 12-1 B	CF 12-1 BUUR	CF 12-1 BUU	105	32	14	12	M12 × 1.5	13
16	CF 16 BR	CF 16 B	CF 16 BUUR	CF 16 BUU	170	35	18	16	M16 × 1.5	17
	CF 16 FBR	—	CF 16 FBUUR	—	170	35	18	16	M16 × 1.5	17
18	CF 18 BR	CF 18 B	CF 18 BUUR	CF 18 BUU	250	40	20	18	M18 × 1.5	19
	CF 18 FBR	—	CF 18 FBUUR	—	250	40	20	18	M18 × 1.5	19
20	CF 20 BR	CF 20 B	CF 20 BUUR	CF 20 BUU	460	52	24	20	M20 × 1.5	21
	CF 20 FBR	—	CF 20 FBUUR	—	460	52	24	20	M20 × 1.5	21
	CF 20-1 BR	CF 20-1 B	CF 20-1 BUUR	CF 20-1 BUU	385	47	24	20	M20 × 1.5	21
24	CF 24 BR	CF 24 B	CF 24 BUUR	CF 24 BUU	815	62	29	24	M24 × 1.5	25
	CF 24-1 BR	CF 24-1 B	CF 24-1 BUUR	CF 24-1 BUU	1 140	72	29	24	M24 × 1.5	25
30	CF 30 BR	CF 30 B	CF 30 BUUR	CF 30 BUU	1 870	80	35	30	M30 × 1.5	32
	CF 30-1 BR	CF 30-1 B	CF 30-1 BUUR	CF 30-1 BUU	2 030	85	35	30	M30 × 1.5	32
	CF 30-2 BR	CF 30-2 B	CF 30-2 BUUR	CF 30-2 BUU	2 220	90	35	30	M30 × 1.5	32

- Note(1) Minimum allowable value of chamfer dimension r
- Remarks1. Models with a stud diameter d_1 of 4 mm or less have no oil hole. For models with a stud dia. 5 to 10mm, oil hole (re-greasing fitting) is provided at the head. Other models are provided with an oil hole (grease nipple) at the head and an oil hole each on the outside surface and end surface of the stud.
2. Shield type models with a stud diameter d_1 of 10mm or less and the sealed type models are provided with prepacked grease. Other models are not provided with prepacked grease. Perform proper lubrication for use.
3. A nut is supplied with the stud.

Boundary dimensions mm										Mounting dimension f Min. mm	Maximum tightening torque N-m	Basic dynamic load rating C N	Basic static load rating C_0 N	Maximum allowable static load N
B	B_1	B_2	B_3	C_1	g_1	g_2	H	$r_{s \min}^{(1)}$	Min. mm					
8	17	9	—	0.5	—	—	2	0.2	6.8	0.34	1 500	1 020	384	
8	17	9	—	0.5	—	—	2	0.2	6.8	0.34	1 200	813	384	
9	20	11	—	0.5	—	—	2.5	0.3	8.3	0.78	2 070	1 590	834	
9	20	11	—	0.5	—	—	2.5	0.3	8.3	0.78	1 650	1 270	834	
10	23	13	—	0.5	—	—	3	0.3	9.3	1.6	2 520	2 140	1 260	
10	23	13	—	0.5	—	—	3	0.3	9.3	1.6	1 930	1 730	1 260	
12.2max	28.2max	16	—	0.6	—	—	3	0.3	11	2.7	3 660	3 650	1 950	
12.2max	28.2max	16	—	0.6	—	—	3	—	11	2.7	2 930	2 920	1 950	
12.2max	32.2max	20	—	0.6	—	—	4	0.3	13	6.5	4 250	4 740	4 620	
12.2max	32.2max	20	—	0.6	—	—	4	0.3	13	7.1	4 250	4 740	4 620	
12.2max	32.2max	20	—	0.6	—	—	4	—	13	6.5	3 400	3 790	3 790	
13.2max	36.2max	23	—	0.6	—	—	4	0.3	16	13.8	5 430	6 890	6 890	
13.2max	36.2max	23	—	0.6	—	—	4	0.3	16	14.7	5 430	6 890	6 890	
13.2max	36.2max	23	—	0.6	—	—	4	—	16	13.8	4 340	5 510	5 510	
13.2max	36.2max	23	—	0.6	—	—	5	0.3	16	13.8	5 430	6 890	6 890	
13.2max	36.2max	23	—	0.6	—	—	4	0.3	16	14.7	5 430	6 890	6 890	
15.2max	40.2max	25	6	0.6	4	3	6	0.6	21	21.9	7 910	9 790	9 790	
15.2max	40.2max	25	6	0.6	4	3	6	—	21	21.9	6 330	7 830	7 830	
15.2max	40.2max	25	6	0.6	4	3	6	0.6	21	21.9	7 910	9 790	9 790	
19.6max	52.1max	32.5	8	0.8	4	3	6	0.6	26	58.5	12 000	18 300	18 300	
19.6max	52.1max	32.5	8	0.8	4	3	6	—	26	58.5	9 620	14 700	14 700	
21.6max	58.1max	36.5	8	0.8	6	3	8	1	29	86.2	14 800	25 200	25 200	
21.6max	58.1max	36.5	8	0.8	6	3	8	—	29	86.2	11 800	20 200	20 200	
25.6max	66.1max	40.5	9	0.8	6	4	8	1	34	119	20 700	34 600	34 600	
25.6max	66.1max	40.5	9	0.8	6	4	8	—	34	119	16 500	27 700	27 700	
25.6max	66.1max	40.5	9	0.8	6	4	8	1	34	119	20 700	34 600	34 600	
30.6max	80.1max	49.5	11	0.8	6	4	12	1	40	215	30 500	52 600	52 000	
30.6max	80.1max	49.5	11	0.8	6	4	12	1	40	215	30 500	52 600	52 000	
37 max	100 max	63	15	1	6	4	17	1	49	438	45 400	85 100	85 100	
37 max	100 max	63	15	1	6	4	17	1	49	438	45 400	85 100	85 100	
37 max	100 max	63	15	1	6	4	17	1	49	438	45 400	85 100	85 100	

IKO Standard Type Cam Followers Full Complement Type/With Hexagon Hole

Selectable product specifications

Material	No symbol	Carbon steel
	F	Stainless steel
Roller guide type	No symbol	Caged
	V	Full complement
Seal structure	No symbol	Shield type
	UU	Sealed type
Shape of outer ring	No symbol	Cylindrical outer ring
	R	Crowned outer ring

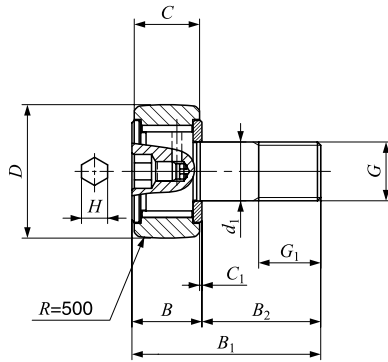

CF...VBR

Stud dia d_1 6 to 10mm

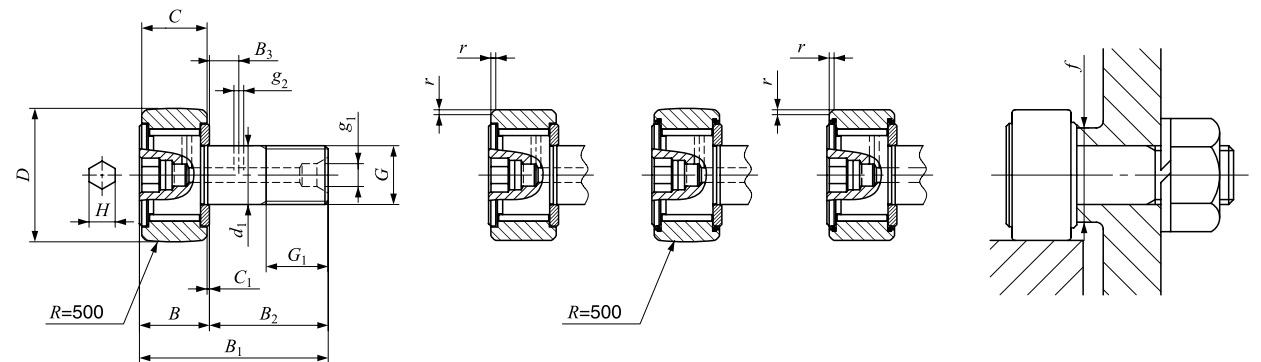

CF...VBR

Stud dia d_1 12 to 30mm

CF...VB

CF...VBUUR

CF...VBUU

Stud dia. mm	Identification number				Mass (Ref.) g	D	C	d_1
	Shield type		Sealed type					
	With crowned outer ring	With cylindrical outer ring	With crowned outer ring	With cylindrical outer ring				
6	CF 6 VBR	CF 6 VB	CF 6 VBUUR	CF 6 VBUU	19	16	11	6
8	CF 8 VBR	CF 8 VB	CF 8 VBUUR	CF 8 VBUU	29	19	11	8
	CF 8 VBRM	CF 8 VBM	CF 8 VBUURM	CF 8 VBUUM	29	19	11	8
10	CF 10 VBR	CF 10 VB	CF 10 VBUUR	CF 10 VBUU	46	22	12	10
	CF 10 VBRM	CF 10 VBM	CF 10 VBUURM	CF 10 VBUUM	46	22	12	10
	CF 10-1 VBR	CF 10-1 VB	CF 10-1 VBUUR	CF 10-1 VBUU	61	26	12	10
	CF 10-1 VBRM	CF 10-1 VBM	CF 10-1 VBUURM	CF 10-1 VBUUM	61	26	12	10
12	CF 12 VBR	CF 12 VB	CF 12 VBUUR	CF 12 VBUU	97	30	14	12
	CF 12-1 VBR	CF 12-1 VB	CF 12-1 VBUUR	CF 12-1 VBUU	107	32	14	12
16	CF 16 VBR	CF 16 VB	CF 16 VBUUR	CF 16 VBUU	173	35	18	16
18	CF 18 VBR	CF 18 VB	CF 18 VBUUR	CF 18 VBUU	255	40	20	18
20	CF 20 VBR	CF 20 VB	CF 20 VBUUR	CF 20 VBUU	465	52	24	20
	CF 20-1 VBR	CF 20-1 VB	CF 20-1 VBUUR	CF 20-1 VBUU	390	47	24	20
24	CF 24 VBR	CF 24 VB	CF 24 VBUUR	CF 24 VBUU	820	62	29	24
	CF 24-1 VBR	CF 24-1 VB	CF 24-1 VBUUR	CF 24-1 VBUU	1 140	72	29	24
30	CF 30 VBR	CF 30 VB	CF 30 VBUUR	CF 30 VBUU	1 870	80	35	30
	CF 30-1 VBR	CF 30-1 VB	CF 30-1 VBUUR	CF 30-1 VBUU	2 030	85	35	30
	CF 30-2 VBR	CF 30-2 VB	CF 30-2 VBUUR	CF 30-2 VBUU	2 220	90	35	30

Note(1) Minimum allowable value of chamfer dimension r
 Remarks1. Models with a stud diameter d_1 of 10 mm or less have an oil hole (re-greasing fitting) at the head. Other models are provided with an oil hole (grease nipple) at the head and an oil hole each on the outside surface and end surface of the stud.
 2. Provided with prepacked grease.
 3. A nut is supplied with the stud.

Boundary dimensions mm											Mounting dimension f Min. mm	Maximum tightening torque N-m	Basic dynamic load rating C N	Basic static load rating C_0 N	Maximum allowable static load N
G	G_1	B max	B_1 max	B_2	B_3	C_1	g_1	g_2	H	$r_{s \min}^{(1)}$					
M 6 × 1	8	12.2	28.2	16	—	0.6	—	—	3	0.3	11	2.7	6 980	8 500	1 950
M 8 × 1.25	10	12.2	32.2	20	—	0.6	—	—	4	0.3	13	6.5	8 170	11 200	4 620
M 8 × 1	10	12.2	32.2	20	—	0.6	—	—	4	0.3	13	7.1	8 170	11 200	4 620
M10 × 1.25	12	13.2	36.2	23	—	0.6	—	—	4	0.3	16	13.8	9 570	14 500	8 650
M10 × 1	12	13.2	36.2	23	—	0.6	—	—	4	0.3	16	14.7	9 570	14 500	8 650
M10 × 1.25	12	13.2	36.2	23	—	0.6	—	—	4	0.3	16	13.8	9 570	14 500	8 650
M10 × 1	12	13.2	36.2	23	—	0.6	—	—	4	0.3	16	14.7	9 570	14 500	8 650
M12 × 1.5	13	15.2	40.2	25	6	0.6	4	3	6	0.6	21	21.9	13 500	19 700	13 200
M12 × 1.5	13	15.2	40.2	25	6	0.6	4	3	6	0.6	21	21.9	13 500	19 700	13 200
M16 × 1.5	17	19.6	52.1	32.5	8	0.8	4	3	6	0.6	26	58.5	20 700	37 600	23 200
M18 × 1.5	19	21.6	58.1	36.5	8	0.8	6	3	8	1	29	86.2	25 300	51 300	31 100
M20 × 1.5	21	25.6	66.1	40.5	9	0.8	6	4	8	1	34	119	33 200	64 500	37 500
M20 × 1.5	21	25.6	66.1	40.5	9	0.8	6	4	8	1	34	119	33 200	64 500	37 500
M24 × 1.5	25	30.6	80.1	49.5	11	0.8	6	4	12	1	40	215	46 600	92 000	52 000
M24 × 1.5	25	30.6	80.1	49.5	11	0.8	6	4	12	1	40	215	46 600	92 000	52 000
M30 × 1.5	32	37	100	63	15	1	6	4	17	1	49	438	67 700	144 000	85 900
M30 × 1.5	32	37	100	63	15	1	6	4	17	1	49	438	67 700	144 000	85 900
M30 × 1.5	32	37	100	63	15	1	6	4	17	1	49	438	67 700	144 000	85 900

IKO Thrust Disk Type Cam Followers With Cage/With Hexagon Hole

Selectable product specifications

Material	No symbol	Carbon steel
	F	Stainless steel
Roller guide type	No symbol	Caged
	V	Full complement
Seal structure	No symbol	Shield type
	UU	Sealed type
Shape of outer ring	No symbol	Cylindrical outer ring
	R	Crowned outer ring

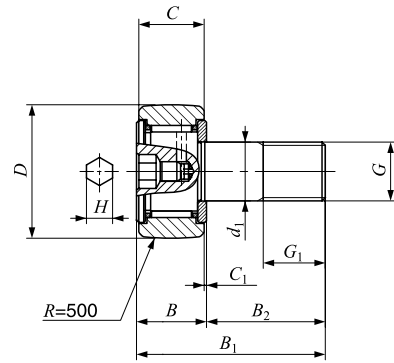

CF...(F)WBR
Stud dia d_1 3 to 10mm

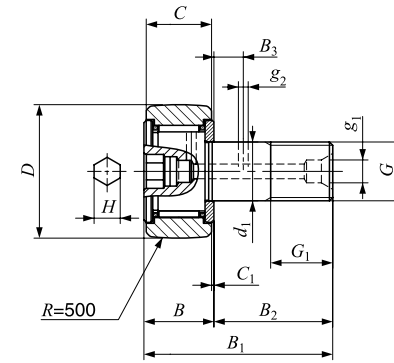

CF...WBR
Stud dia d_1 12 to 20mm

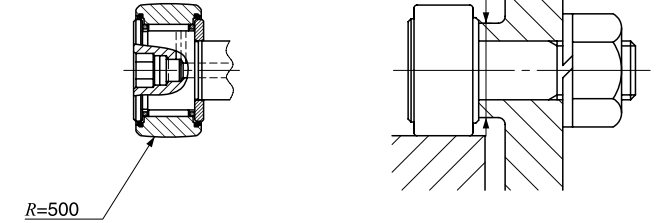

CF...(F)WBUUR

Stud dia. mm	Identification number		Mass (Ref.) g	Boundary dimensions mm				
	Shield type	Sealed type		D	C	d_1	G	G_1
3	CF 3 WBR	CF 3 WBUUR	4.3	10	7	3	M 3×0.5	5
	CF 3 FWBR	CF 3 FWBUUR	4.3	10	7	3	M 3×0.5	5
4	CF 4 WBR	CF 4 WBUUR	7.4	12	8	4	M 4×0.7	6
	CF 4 FWBR	CF 4 FWBUUR	7.4	12	8	4	M 4×0.7	6
5	CF 5 WBR	CF 5 WBUUR	10.3	13	9	5	M 5×0.8	7.5
	CF 5 FWBR	CF 5 FWBUUR	10.3	13	9	5	M 5×0.8	7.5
6	CF 6 WBR	CF 6 WBUUR	18.5	16	11	6	M 6×1	8
8	CF 8 WBR	CF 8 WBUUR	28.5	19	11	8	M 8×1.25	10
10	CF 10 WBR	CF 10 WBUUR	45	22	12	10	M10×1.25	12
	CF 10-1 WBR	CF 10-1 WBUUR	60	26	12	10	M10×1.25	12
12	CF 12 WBR	CF 12 WBUUR	95	30	14	12	M12×1.5	13
	CF 12-1 WBR	CF 12-1 WBUUR	105	32	14	12	M12×1.5	13
16	CF 16 WBR	CF 16 WBUUR	170	35	18	16	M16×1.5	17
18	CF 18 WBR	CF 18 WBUUR	250	40	20	18	M18×1.5	19
20	CF 20 WBR	CF 20 WBUUR	460	52	24	20	M20×1.5	21
	CF 20-1 WBR	CF 20-1 WBUUR	385	47	24	20	M20×1.5	21

- Remarks1. Models with a stud diameter d_1 of 4 mm or less have no oil hole. For Models with a stud dia. 5 to 10 mm, oil hole (re-greasing fitting) is provided at the head. Other models are provided with an oil hole (grease nipple) at the head and an oil hole each on the outside surface and end surface of the stud.
2. Shield type models with a stud diameter d_1 of 10 mm or less and the sealed type models are provided with prepacked grease. Other models are not provided with prepacked grease. Perform proper lubrication for use.
3. A nut is supplied with the stud.

B	B_1	B_2	B_3	C_1	g_1	g_2	H	Mounting dimension f Min. mm	Maximum tightening torque N-m	Basic dynamic load rating C N	Basic static load rating C_0 N	Maximum allowable static load N
8	17	9	—	0.5	—	—	2	6.8	0.34	1 500	1 020	384
8	17	9	—	0.5	—	—	2	6.8	0.34	1 200	813	384
9	20	11	—	0.5	—	—	2.5	8.3	0.78	2 070	1 590	834
9	20	11	—	0.5	—	—	2.5	8.3	0.78	1 650	1 270	834
10	23	13	—	0.5	—	—	3	9.3	1.6	2 520	2 140	1 260
10	23	13	—	0.5	—	—	3	9.3	1.6	1 930	1 730	1 260
12.2max	28.2max	16	—	0.6	—	—	3	11	2.7	3 660	3 650	1 950
12.2max	32.2max	20	—	0.6	—	—	4	13	6.5	4 250	4 740	4 620
13.2max	36.2max	23	—	0.6	—	—	4	16	13.8	5 430	6 890	6 890
13.2max	36.2max	23	—	0.6	—	—	4	16	13.8	5 430	6 890	6 890
15.2max	40.2max	25	6	0.6	4	3	6	21	21.9	7 910	9 790	9 790
15.2max	40.2max	25	6	0.6	4	3	6	21	21.9	7 910	9 790	9 790
19.6max	52.1max	32.5	8	0.8	4	3	6	26	58.5	12 000	18 300	18 300
21.6max	58.1max	36.5	8	0.8	6	3	8	29	86.2	14 800	25 200	25 200
25.6max	66.1max	40.5	9	0.8	6	4	8	34	119	20 700	34 600	34 600
25.6max	66.1max	40.5	9	0.8	6	4	8	34	119	20 700	34 600	34 600

IKO C-Lube Cam Followers With Cage/With Hexagon Hole

Selectable product specifications

Material	No symbol	Carbon steel
	F	Stainless steel
Roller guide type	No symbol	Caged
	V	Full complement
Seal structure	No symbol	Shield type
	UU	Sealed type
Shape of outer ring	No symbol	Cylindrical outer ring
	R	Crowned outer ring

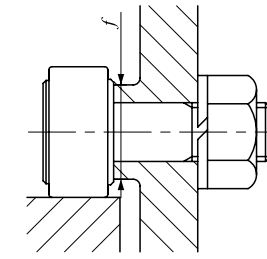
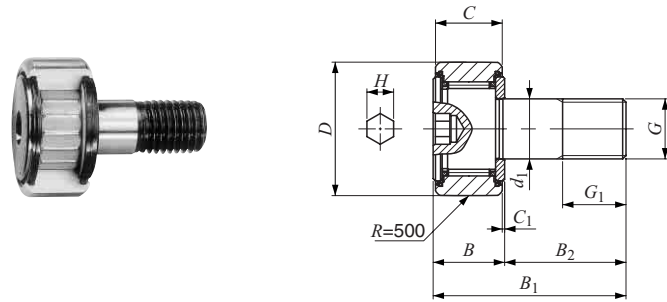

Stud dia. mm	Identification number	Mass (Ref.) g	Boundary dimensions mm						
			D	C	d ₁	G	G ₁	B	B ₁
5	CF 5 WBUUR/SG	10.3	13	9	5	M 5 × 0.8	7.5	10	23
6	CF 6 WBUUR/SG	18.5	16	11	6	M 6 × 1	8	12.2 max	28.2 max
8	CF 8 WBUUR/SG	28.5	19	11	8	M 8 × 1.25	10	12.2 max	32.2 max
10	CF 10 WBUUR/SG	45	22	12	10	M10 × 1.25	12	13.2 max	36.2 max
	CF 10-1 WBUUR/SG	60	26	12	10	M10 × 1.25	12	13.2 max	36.2 max
12	CF 12 WBUUR/SG	95	30	14	12	M12 × 1.5	13	15.2 max	40.2 max
	CF 12-1 WBUUR/SG	105	32	14	12	M12 × 1.5	13	15.2 max	40.2 max
16	CF 16 WBUUR/SG	170	35	18	16	M16 × 1.5	17	19.6 max	52.1 max
18	CF 18 WBUUR/SG	250	40	20	18	M18 × 1.5	19	21.6 max	58.1 max
20	CF 20 WBUUR/SG	460	52	24	20	M20 × 1.5	21	25.6 max	66.1 max
	CF 20-1 WBUUR/SG	385	47	24	20	M20 × 1.5	21	25.6 max	66.1 max

- Remarks1. Please do not Wash with organic solvent and/or white kerosene which have the ability to remove fat.
 2. To ensure normal rotation of the bearing, apply a load of 1% or more of the basic dynamic load rating at use.
 3. The operating temperature range is -15~+80°C. Continuous operating temperature is +60°C or less.
 4. Regreasing is not possible as the bearing internal space is filled with thermosetting solid-type lubricant C-Lube.
 5. A nut is supplied with the stud.

B ₂	C ₁	H	Mounting dimension f Min. mm	Maximum tightening torque N-m	Basic dynamic load rating C N	Basic static load rating C ₀ N	Maximum allowable static load N
16	0.6	3	11	2.7	3 660	3 650	1 950
20	0.6	4	13	6.5	4 250	4 740	4 620
23	0.6	4	16	13.8	5 430	6 890	6 890
			16	13.8	5 430	6 890	6 890
25	0.6	6	21	21.9	7 910	9 790	9 790
			21	21.9	7 910	9 790	9 790
32.5	0.8	6	26	58.5	12 000	18 300	18 300
36.5	0.8	8	29	86.2	14 800	25 200	25 200
40.5	0.8	8	34	119	20 700	34 600	34 600

IKO Solid Eccentric Stud Type Cam Followers With Cage/With Hexagon Hole

Selectable product specifications

Material	No symbol	Carbon steel
	F	Stainless steel
Roller guide type	No symbol	Caged
	V	Full complement
Seal structure	No symbol	Shield type
	UU	Sealed type
Shape of outer ring	No symbol	Cylindrical outer ring
	R	Crowned outer ring

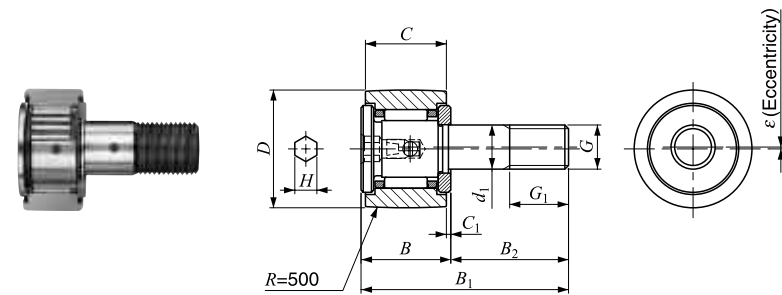

CFES...BR

Stud dia d_1 6 to 10mm

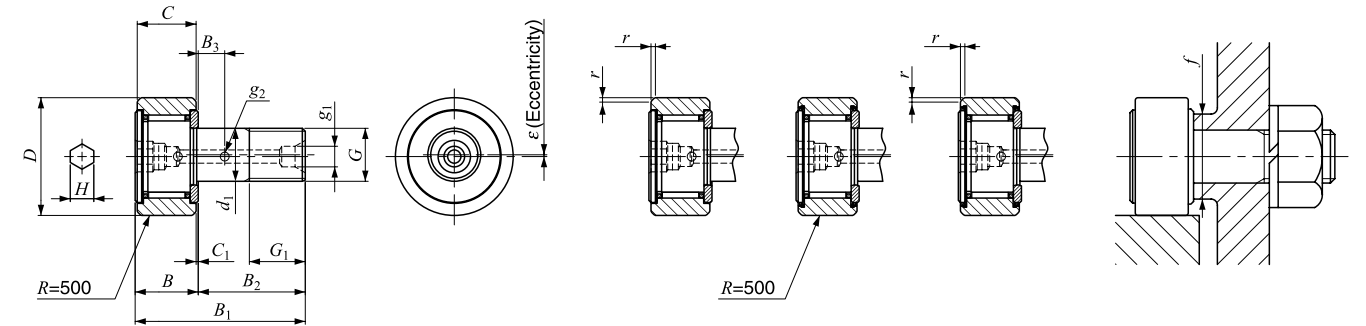

CFES...BR

Stud dia d_1 12 to 18mm

CFES...B

CFES...BUUR

CFES...BUU

Stud dia. mm	Identification number				Mass (Ref.) g	D	C	d_1
	Shield type		Sealed type					
	With crowned outer ring	With cylindrical outer ring	With crowned outer ring	With cylindrical outer ring				
6	CFES 6 BR	CFES 6 B	CFES 6 BUUR	CFES 6 BUU	18.5	16	11	6
8	CFES 8 BR	CFES 8 B	CFES 8 BUUR	CFES 8 BUU	28.5	19	11	8
10	CFES 10 BR	CFES 10 B	CFES 10 BUUR	CFES 10 BUU	45	22	12	10
	CFES 10-1 BR	CFES 10-1 B	CFES 10-1 BUUR	CFES 10-1 BUU	60	26	12	10
12	CFES 12 BR	CFES 12 B	CFES 12 BUUR	CFES 12 BUU	95	30	14	12
	CFES 12-1 BR	CFES 12-1 B	CFES 12-1 BUUR	CFES 12-1 BUU	105	32	14	12
16	CFES 16 BR	CFES 16 B	CFES 16 BUUR	CFES 16 BUU	170	35	18	16
18	CFES 18 BR	CFES 18 B	CFES 18 BUUR	CFES 18 BUU	250	40	20	18

- Note(1) Minimum allowable value of chamfer dimension r
- Remarks 1. Models with a stud diameter d_1 of 10 mm or less have an oil hole (re-greasing fitting) at the head. Other models are provided with an oil hole (grease nipple) at the head and an oil hole each on the outside surface and end surface of the stud.
2. Shield type models with a stud diameter d_1 of 10 mm or less and the sealed type models are provided with prepacked grease. Other models are not provided with prepacked grease. Perform proper lubrication for use.
3. A nut is supplied with the stud.

Boundary dimensions mm													Mounting dimension f Min. mm	Maximum tightening torque N-m	Basic dynamic load rating C N	Basic static load rating C_0 N	Maximum allowable static load N
G	G_1	B max	B_1 max	B_2	B_3	C_1	g_1	g_2	H	$r_{s \min}^{(1)}$	Eccentricity ϵ						
M 6 × 1	8	12.2	28.2	16	—	0.6	—	—	3	0.3	0.25	11	2.7	3 660	3 650	1 980	
M 8 × 1.25	10	12.2	32.2	20	—	0.6	—	—	4	0.3	0.25	13	6.5	4 250	4 740	4 670	
M10 × 1.25	12	13.2	36.2	23	—	0.6	—	—	4	0.3	0.3	16	13.8	5 430	6 890	6 890	
M10 × 1.25	12	13.2	36.2	23	—	0.6	—	—	4	0.3	0.3	16	13.8	5 430	6 890	6 890	
M12 × 1.5	13	15.2	40.2	25	6	0.6	4	3	6	0.6	0.4	21	21.9	7 910	9 790	9 790	
M12 × 1.5	13	15.2	40.2	25	6	0.6	4	3	6	0.6	0.4	21	21.9	7 910	9 790	9 790	
M16 × 1.5	17	19.6	52.1	32.5	8	0.8	4	3	6	0.6	0.5	26	58.5	12 000	18 300	18 300	
M18 × 1.5	19	21.6	58.1	36.5	8	0.8	6	3	8	1	0.6	29	86.2	14 800	25 200	25 200	

IKO Eccentric Type Cam Followers With Cage/With Hexagon Hole

Selectable product specifications

Material	No symbol	Carbon steel
	F	Stainless steel
Roller guide type	No symbol	Caged
	V	Full complement
Seal structure	No symbol	Shield type
	UU	Sealed type
Shape of outer ring	No symbol	Cylindrical outer ring
	R	Crowned outer ring

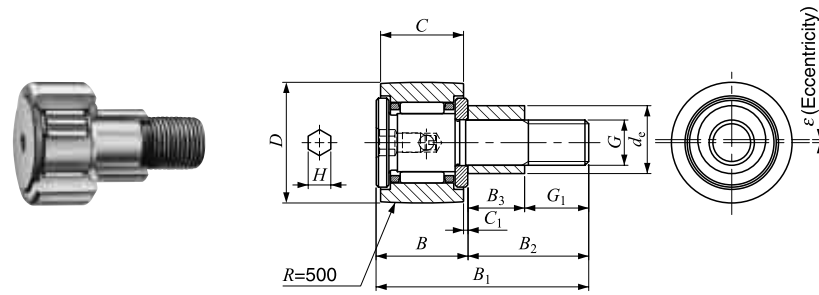

CFE...BR

Outside diameter of eccentric collar d_e 9 to 13mm

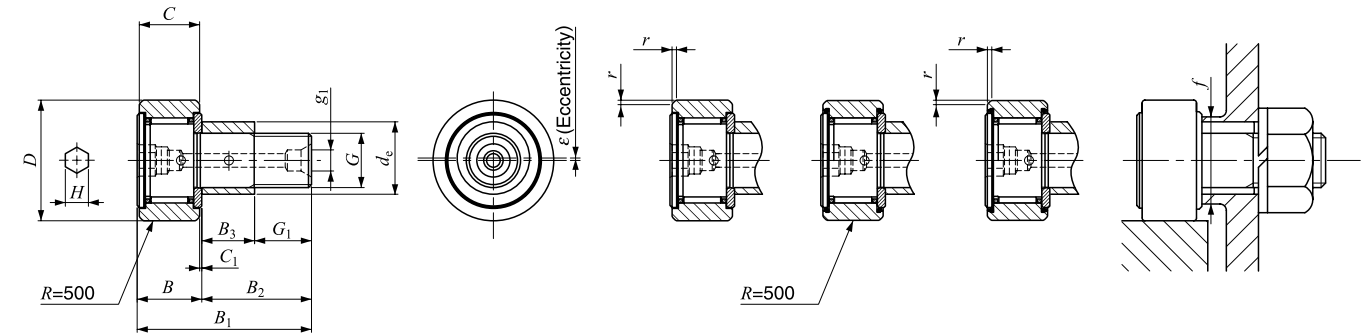

CFE...BR

CFE...B

CFE...BUUR

CFE...BUU

Outside diameter of eccentric collar d_e 16 to 41mm

Outside diameter of eccentric collar mm	Identification number				Mass (Ref.) g	D	C	d_e
	Shield type		Sealed type					
	With crowned outer ring	With cylindrical outer ring	With crowned outer ring	With cylindrical outer ring				
9	CFE 6 BR	CFE 6 B	CFE 6 BUUR	CFE 6 BUU	20.5	16	11	9
11	CFE 8 BR	CFE 8 B	CFE 8 BUUR	CFE 8 BUU	32	19	11	11
13	CFE 10 BR	CFE 10 B	CFE 10 BUUR	CFE 10 BUU	49.5	22	12	13
	CFE 10-1 BR	CFE 10-1 B	CFE 10-1 BUUR	CFE 10-1 BUU	65	26	12	13
16	CFE 12 BR	CFE 12 B	CFE 12 BUUR	CFE 12 BUU	105	30	14	16
	CFE 12-1 BR	CFE 12-1 B	CFE 12-1 BUUR	CFE 12-1 BUU	115	32	14	16
22	CFE 16 BR	CFE 16 B	CFE 16 BUUR	CFE 16 BUU	190	35	18	22
24	CFE 18 BR	CFE 18 B	CFE 18 BUUR	CFE 18 BUU	280	40	20	24
27	CFE 20 BR	CFE 20 B	CFE 20 BUUR	CFE 20 BUU	500	52	24	27
	CFE 20-1 BR	CFE 20-1 B	CFE 20-1 BUUR	CFE 20-1 BUU	425	47	24	27
33	CFE 24 BR	CFE 24 B	CFE 24 BUUR	CFE 24 BUU	895	62	29	33
	CFE 24-1 BR	CFE 24-1 B	CFE 24-1 BUUR	CFE 24-1 BUU	1 220	72	29	33
41	CFE 30 BR	CFE 30 B	CFE 30 BUUR	CFE 30 BUU	2 030	80	35	41
	CFE 30-1 BR	CFE 30-1 B	CFE 30-1 BUUR	CFE 30-1 BUU	2 190	85	35	41
	CFE 30-2 BR	CFE 30-2 B	CFE 30-2 BUUR	CFE 30-2 BUU	2 380	90	35	41

- Note(1) Minimum allowable value of chamfer dimension r
- Remarks1. Models with a thread diameter G of 10 mm or less have an oil hole (re-greasing fitting) at the head. Other models are provided with an oil hole (grease nipple) at the head and an oil hole on the end surface of the stud.
2. Shield type models with a stud thread diameter G of 10 mm or less and the sealed type models are provided with prepacked grease. Other models are not provided with prepacked grease. Perform proper lubrication for use.
3. A nut is supplied with the stud.

Boundary dimensions mm											Eccentricity ϵ	Mounting dimension f Min. mm	Maximum tightening torque N-m	Basic dynamic load rating C N	Basic static load rating C_0 N	Maximum allowable static load N
G	B_3	B_{max}	B_1_{max}	B_2	C_1	g_1	G_1	H	$r_{s min}^{(1)}$	ϵ						
M 6 × 1	7.5	12.2	28.2	16	0.6	—	8.5	3	0.3	0.4	11	2.7	3 660	3 650	1 950	
M 8 × 1.25	9.5	12.2	32.2	20	0.6	—	10.5	4	0.3	0.4	13	6.5	4 250	4 740	4 620	
M10 × 1.25	10.5	13.2	36.2	23	0.6	—	12.5	4	0.3	0.4	16	13.8	5 430	6 890	6 890	
	10.5	13.2	36.2	23	0.6	—	12.5	4	0.3	0.4	16	13.8	5 430	6 890	6 890	
M12 × 1.5	11.5	15.2	40.2	25	0.6	4	13.5	6	0.6	0.8	21	21.9	7 910	9 790	9 790	
	11.5	15.2	40.2	25	0.6	4	13.5	6	0.6	0.8	21	21.9	7 910	9 790	9 790	
M16 × 1.5	15.5	19.6	52.1	32.5	0.8	4	17	6	0.6	0.8	26	58.5	12 000	18 300	18 300	
M18 × 1.5	17.5	21.6	58.1	36.5	0.8	6	19	8	1	0.8	29	86.2	14 800	25 200	25 200	
M20 × 1.5	19.5	25.6	66.1	40.5	0.8	6	21	8	1	0.8	34	119	20 700	34 600	34 600	
	19.5	25.6	66.1	40.5	0.8	6	21	8	1	0.8	34	119	20 700	34 600	34 600	
M24 × 1.5	25.5	30.6	80.1	49.5	0.8	6	24	12	1	0.8	40	215	30 500	52 600	52 000	
	25.5	30.6	80.1	49.5	0.8	6	24	12	1	0.8	40	215	30 500	52 600	52 000	
M30 × 1.5	32.5	37	100	63	1	6	30.5	17	1	1.5	49	438	45 400	85 100	85 100	
	32.5	37	100	63	1	6	30.5	17	1	1.5	49	438	45 400	85 100	85 100	
	32.5	37	100	63	1	6	30.5	17	1	1.5	49	438	45 400	85 100	85 100	

IKO Eccentric Type Cam Followers Full Complement Type/With Hexagon Hole

Selectable product specifications

Material	No symbol	Carbon steel
	F	Stainless steel
Roller guide type	No symbol	Caged
	V	Full complement
Seal structure	No symbol	Shield type
	UU	Sealed type
Shape of outer ring	No symbol	Cylindrical outer ring
	R	Crowned outer ring

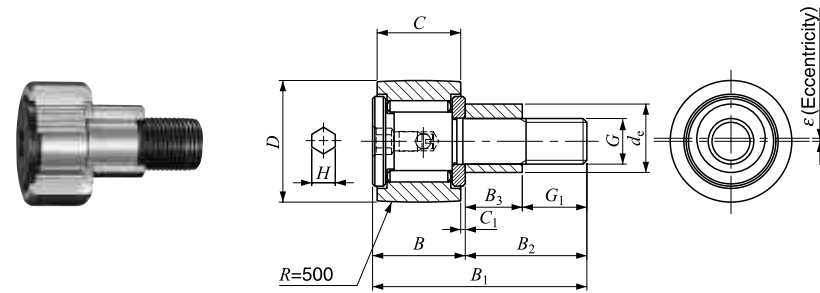

CFE...VBR

Outside diameter of eccentric collar d_e 9 to 13mm

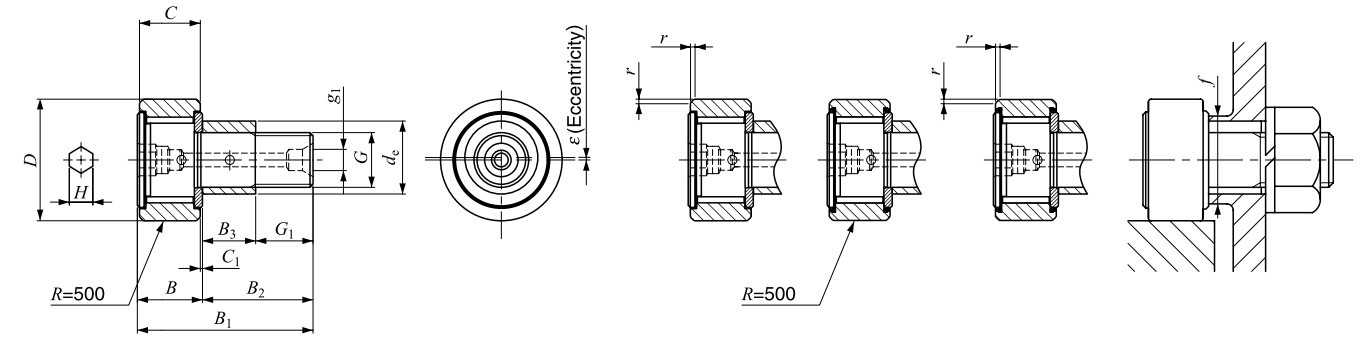

CFE...VBR

CFE...VB

CFE...VBUUR

CFE...VBUU

Outside diameter of eccentric collar d_e 16 to 41mm

Outside diameter of eccentric collar mm	Identification number				Mass (Ref.) g	D	C	d_e
	Shield type		Sealed type					
	With crowned outer ring	With cylindrical outer ring	With crowned outer ring	With cylindrical outer ring				
9	CFE 6 VBR	CFE 6 VB	CFE 6 VBUUR	CFE 6 VBUU	21	16	11	9
11	CFE 8 VBR	CFE 8 VB	CFE 8 VBUUR	CFE 8 VBUU	32.5	19	11	11
13	CFE 10 VBR	CFE 10 VB	CFE 10 VBUUR	CFE 10 VBUU	50.5	22	12	13
	CFE 10-1 VBR	CFE 10-1 VB	CFE 10-1 VBUUR	CFE 10-1 VBUU	66	26	12	13
16	CFE 12 VBR	CFE 12 VB	CFE 12 VBUUR	CFE 12 VBUU	107	30	14	16
	CFE 12-1 VBR	CFE 12-1 VB	CFE 12-1 VBUUR	CFE 12-1 VBUU	117	32	14	16
22	CFE 16 VBR	CFE 16 VB	CFE 16 VBUUR	CFE 16 VBUU	193	35	18	22
24	CFE 18 VBR	CFE 18 VB	CFE 18 VBUUR	CFE 18 VBUU	285	40	20	24
27	CFE 20 VBR	CFE 20 VB	CFE 20 VBUUR	CFE 20 VBUU	505	52	24	27
	CFE 20-1 VBR	CFE 20-1 VB	CFE 20-1 VBUUR	CFE 20-1 VBUU	430	47	24	27
33	CFE 24 VBR	CFE 24 VB	CFE 24 VBUUR	CFE 24 VBUU	900	62	29	33
	CFE 24-1 VBR	CFE 24-1 VB	CFE 24-1 VBUUR	CFE 24-1 VBUU	1 220	72	29	33
41	CFE 30 VBR	CFE 30 VB	CFE 30 VBUUR	CFE 30 VBUU	2 030	80	35	41
	CFE 30-1 VBR	CFE 30-1 VB	CFE 30-1 VBUUR	CFE 30-1 VBUU	2 190	85	35	41
	CFE 30-2 VBR	CFE 30-2 VB	CFE 30-2 VBUUR	CFE 30-2 VBUU	2 380	90	35	41

- Note(1) Minimum allowable value of chamfer dimension r
- Remarks1. Models with a thread diameter G of 10 mm or less have an oil hole (re-greasing fitting) at the head. Other models are provided with an oil hole (grease nipple) at the head and an oil hole on the end surface of the stud.
2. Provided with prepacked grease.
 3. A nut is supplied with the stud.

Boundary dimensions mm											Eccentricity ϵ	Mounting dimension f Min. mm	Maximum tightening torque N-m	Basic dynamic load rating C N	Basic static load rating C_0 N	Maximum allowable static load N
G	B_3	B_{max}	B_1_{max}	B_2	C_1	g_1	G_1	H	$r_{s min}^{(1)}$	ϵ						
M 6 × 1	7.5	12.2	28.2	16	0.6	—	8.5	3	0.3	0.4	11	2.7	6 980	8 500	1 950	
M 8 × 1.25	9.5	12.2	32.2	20	0.6	—	10.5	4	0.3	0.4	13	6.5	8 170	11 200	4 620	
M10 × 1.25	10.5	13.2	36.2	23	0.6	—	12.5	4	0.3	0.4	16	13.8	9 570	14 500	8 650	
	10.5	13.2	36.2	23	0.6	—	12.5	4	0.3	0.4	16	13.8	9 570	14 500	8 650	
M12 × 1.5	11.5	15.2	40.2	25	0.6	4	13.5	6	0.6	0.8	21	21.9	13 500	19 700	13 200	
	11.5	15.2	40.2	25	0.6	4	13.5	6	0.6	0.8	21	21.9	13 500	19 700	13 200	
M16 × 1.5	15.5	19.6	52.1	32.5	0.8	4	17	6	0.6	0.8	26	58.5	20 700	37 600	23 200	
M18 × 1.5	17.5	21.6	58.1	36.5	0.8	6	19	8	1	0.8	29	86.2	25 300	51 300	31 100	
M20 × 1.5	19.5	25.6	66.1	40.5	0.8	6	21	8	1	0.8	34	119	33 200	64 500	37 500	
	19.5	25.6	66.1	40.5	0.8	6	21	8	1	0.8	34	119	33 200	64 500	37 500	
M24 × 1.5	25.5	30.6	80.1	49.5	0.8	6	24	12	1	0.8	40	215	46 600	92 000	52 000	
	25.5	30.6	80.1	49.5	0.8	6	24	12	1	0.8	40	215	46 600	92 000	52 000	
M30 × 1.5	32.5	37	100	63	1	6	30.5	17	1	1.5	49	438	67 700	144 000	85 900	
	32.5	37	100	63	1	6	30.5	17	1	1.5	49	438	67 700	144 000	85 900	
	32.5	37	100	63	1	6	30.5	17	1	1.5	49	438	67 700	144 000	85 900	

IKO Centralized Lubrication Type Cam Followers With Cage/With Screwdriver Slot

Selectable product specifications

Material	No symbol	Carbon steel
	F	Stainless steel
Roller guide type	No symbol	Caged
	V	Full complement
Seal structure	No symbol	Shield type
	FU1	Cylindrical outer ring
Shape of outer ring	FU1	Cylindrical outer ring
	RU1	Crowned outer ring

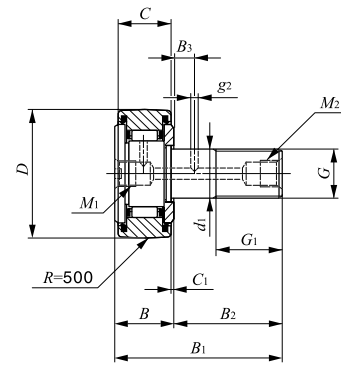

CF-RU1

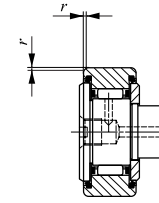

CF-FU1

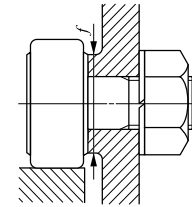

Stud dia. mm	Identification number		Mass (Ref.) g	Boundary dimensions mm				
	With crowned outer ring	With cylindrical outer ring		D	C	d ₁	G	G ₁
6	CF-RU1- 6	CF-FU1- 6	18.5	16	11	6	M 6 × 1	8
8	CF-RU1- 8	CF-FU1- 8	28.5	19	11	8	M 8 × 1.25	10
10	CF-RU1-10 CF-RU1-10-1	CF-FU1-10 CF-FU1-10-1	45	22	12	10	M10 × 1.25	12
			60	26	12	10	M10 × 1.25	12
12	CF-RU1-12 CF-RU1-12-1	CF-FU1-12 CF-FU1-12-1	95	30	14	12	M12 × 1.5	13
			105	32	14	12	M12 × 1.5	13
16	CF-RU1-16	CF-FU1-16	170	35	18	16	M16 × 1.5	17
18	CF-RU1-18	CF-FU1-18	250	40	20	18	M18 × 1.5	19
20	CF-RU1-20 CF-RU1-20-1	CF-FU1-20 CF-FU1-20-1	460	52	24	20	M20 × 1.5	21
			385	47	24	20	M20 × 1.5	21
24	CF-RU1-24 CF-RU1-24-1	CF-FU1-24 CF-FU1-24-1	815	62	29	24	M24 × 1.5	25
			1 140	72	29	24	M24 × 1.5	25
30	CF-RU1-30 CF-RU1-30-1 CF-RU1-30-2	CF-FU1-30 CF-FU1-30-1 CF-FU1-30-2	1 870	80	35	30	M30 × 1.5	32
			2 030	85	35	30	M30 × 1.5	32
			2 220	90	35	30	M30 × 1.5	32

Note(1) Minimum allowable value of chamfer dimension *r*
 Remarks1. Models with a stud diameter *d*₁ of 12 mm or less are provided with a lubrication tapped hole on the stud head only. Other models are provided with one lubrication tapped hole each on the head and end surface of the stud.
 2. Provided with prepacked grease.
 3. A nut is supplied with the stud.

B max	B ₁ max	B ₂	B ₃	C ₁	g ₂	M ₁	M ₂	r _{s min} ⁽¹⁾	Mounting dimension <i>f</i> Min. mm	Maximum tightening torque N-m	Basic dynamic load rating <i>C</i> N	Basic static load rating <i>C</i> ₀ N	Maximum allowable static load N
12.2	28.2	16	—	0.6	—	M6× 0.75	—	0.3	11	2.7	3 660	3 650	1 950
12.2	32.2	20	—	0.6	—			0.3	13	6.5	4 250	4 740	4 620
13.2	36.2	23	—	0.6	—			0.3	16	13.8	5 430	6 890	6 890
13.2	36.2	23	—	0.6	—			0.3	16	13.8	5 430	6 890	6 890
15.2	40.2	25	—	0.6	—			0.6	21	23.9	7 910	9 790	9 790
15.2	40.2	25	—	0.6	—			0.6	21	23.9	7 910	9 790	9 790
19.6	52.1	32.5	8	0.8	3	PT 1/8	PT 1/8	0.6	26	58.5	12 000	18 300	18 300
21.6	58.1	36.5	8	0.8	3			1	29	86.2	14 800	25 200	25 200
25.6	66.1	40.5	9	0.8	4			1	34	119	20 700	34 600	34 600
25.6	66.1	40.5	9	0.8	4			1	34	119	20 700	34 600	34 600
30.6	80.1	49.5	11	0.8	4			1	40	215	30 500	52 600	52 000
30.6	80.1	49.5	11	0.8	4			1	40	215	30 500	52 600	52 000
37	100	63	15	1	4			1	49	438	45 400	85 100	85 100
37	100	63	15	1	4			1	49	438	45 400	85 100	85 100
37	100	63	15	1	4			1	49	438	45 400	85 100	85 100

IKO Easy Mounting Type Cam Followers With Cage/With Hexagon Hole

Selectable product specifications

Material	No symbol	Carbon steel
	F	Stainless steel
Roller guide type	No symbol	Caged
	V	Full complement
Seal structure	No symbol	Shield type
Shape of outer ring	No symbol	Cylindrical outer ring

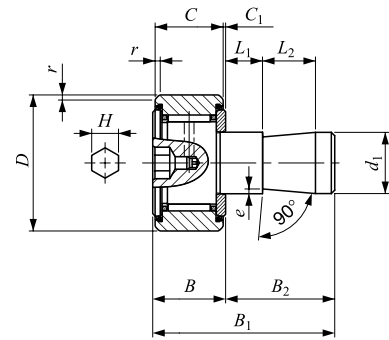

Stud dia d_1 6~10mm

Stud dia. mm	Identification number	Mass (Ref.) g	Boundary dimensions mm							
			D	C	d_1	B_{max}	B_{1max}	B_2	C_1	L_1
6	CF-SFU- 6 B	19.5	16	11	6	12.2	32	19.8	0.6	5
8	CF-SFU- 8 B	29	19	11	8	12.2	32	19.8	0.6	5
10	CF-SFU- 10 B	44	22	12	10	13.2	33	19.8	0.6	5
	CF-SFU- 10-1 B	59	26	12	10	13.2	33	19.8	0.6	5
12	CF-SFU- 12 B	94	30	14	12	15.2	35	19.8	0.6	5
	CF-SFU- 12-1 B	104	32	14	12	15.2	35	19.8	0.6	5
16	CF-SFU- 16 B	164	35	18	16	19.6	44.5	24.9	0.8	10
18	CF-SFU- 18 B	235	40	20	18	21.6	46.5	24.9	0.8	10
20	CF-SFU- 20 B	435	52	24	20	25.6	50.5	24.9	0.8	10
	CF-SFU- 20-1 B	360	47	24	20	25.6	50.5	24.9	0.8	10

Note(1) Minimum allowable value of chamfer dimension r
 Remarks1. Models with a stud diameter d_1 of 10 mm or less have an oil hole (re-greasing fitting) at the head. Other models are provided with an oil hole (grease nipple) at the head.
 2. Provided with prepacked grease.

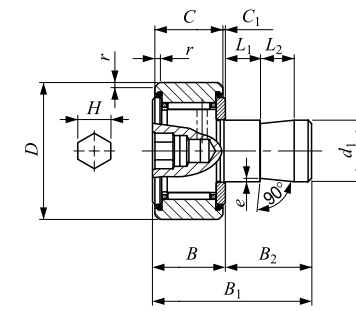

Stud dia d_1 12~20mm

L_2	H	e	$r_{s min}^{(1)}$	Mounting dimensions mm					Basic dynamic load rating C N	Basic static load rating C_0 N	Maximum allowable static load N
				D_1	Tolerance	t Min.	f Min.	h (Ref.)			
10	3	0.3	0.3	6	+0.012 0	20	11	10	3 660	3 650	1 950
10	4	0.5	0.3	8	+0.015 0	20	13	10	4 250	4 740	4 620
10	4	0.5	0.3	10		20	16	10	5 430	6 890	6 890
10	4	0.5	0.3	10	+0.018 0	20	16	10	5 430	6 890	6 890
10	6	1	0.6	12		20	21	10	7 910	9 790	9 790
10	6	1	0.6	12	+0.018 0	20	21	10	7 910	9 790	9 790
10	6	1	0.6	16		25	26	15	12 000	18 300	18 300
10	8	1	1	18	+0.021 0	25	29	15	14 800	25 200	25 200
10	8	1	1	20		25	34	15	20 700	34 600	34 600
10	8	1	1	20	+0.021 0	25	34	15	20 700	34 600	34 600
10	8	1	1	20		25	34	15	20 700	34 600	34 600

IKO Cylindrical Roller Cam Followers Full Complement Type/With Hexagon Hole

Selectable product specifications

Material	No symbol	Carbon steel
	F	Stainless steel
Roller guide type	No symbol	Caged
	UU	Sealed type
Seal structure	No symbol	Full complement
	UU	Sealed type
Shape of outer ring	No symbol	Cylindrical outer ring
	R	Crowned outer ring

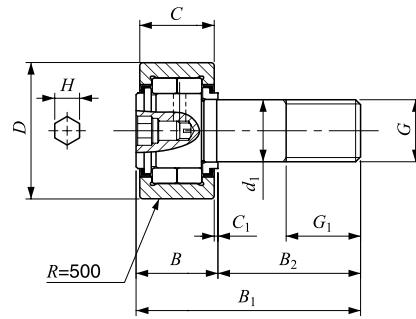
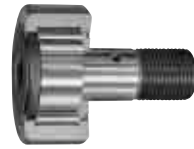

Stud dia d_1 10mm

Stud dia. mm	Identification number	Mass (Ref.) g	Boundary dimensions mm							
			D	C	d_1	G	G_1	B max	B_1 max	B_2
10	NUCF 10 BR	44	22	12	10	M10 × 1.25	12	13.2	36.2	23
	NUCF 10-1 BR	58	26	12	10	M10 × 1.25	12	13.2	36.2	23
12	NUCF 12 BR	86	30	14	12	M12 × 1.5	13	15.2	40.2	25
	NUCF 12-1 BR	97	32	14	12	M12 × 1.5	13	15.2	40.2	25
16	NUCF 16 BR	167	35	18	16	M16 × 1.5	17	19.6	52.1	32.5
18	NUCF 18 BR	244	40	20	18	M18 × 1.5	19	21.6	58.1	36.5
20	NUCF 20 BR	457	52	24	20	M20 × 1.5	21	25.6	66.1	40.5
	NUCF 20-1 BR	384	47	24	20	M20 × 1.5	21	25.6	66.1	40.5
24	NUCF 24 BR	789	62	29	24	M24 × 1.5	25	30.6	80.1	49.5
	NUCF 24-1 BR	1 020	72	29	24	M24 × 1.5	25	30.6	80.1	49.5
30	NUCF 30 BR	1 600	80	35	30	M30 × 1.5	32	37	100	63
	NUCF 30-2 BR	1 970	90	35	30	M30 × 1.5	32	37	100	63

Remarks1. Model with a stud diameter d_1 of 10 mm is provided with an oil hole (re-greasing fitting) on the stud head only. Other models are provided with one oil hole each on the head, outside surface and end surface of the stud.
 2. Provided with prepacked grease.
 3. A nut is supplied with the stud.

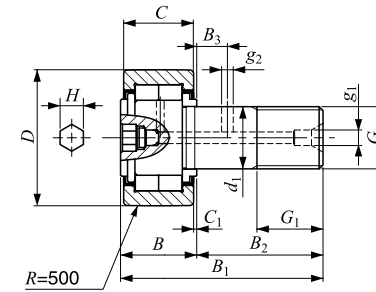

Stud dia d_1 12 to 30mm

B_3	C_1	g_1	g_2	H	Mounting dimension	Maximum tightening torque	Basic dynamic load rating C	Basic static load rating C_0	Maximum allowable static load
					f Min. mm				
—	0.6	—	—	4	12	13.8	10 400	11 500	5 300
—	0.6	—	—	4	12	13.8	10 400	11 500	9 210
6	0.6	4	3	6	17	21.9	14 000	13 400	5 650
6	0.6	4	3	6	17	21.9	14 000	13 400	9 040
8	0.8	4	3	6	20	58.5	23 400	27 300	11 800
8	0.8	6	3	8	22	86.2	25 200	30 900	20 300
9	0.8	6	4	8	31	119	43 100	58 100	30 000
9	0.8	6	4	8	27	119	38 900	49 000	27 200
11	0.8	6	4	12	38	215	58 200	75 300	35 200
11	0.8	6	4	12	44	215	63 900	88 800	57 000
15	1	6	4	17	45	438	90 300	121 000	98 300
15	1	6	4	17	45	438	90 300	121 000	98 300

IKO Inch Series Cam Followers With Cage/With Hexagon Hole

Selectable product specifications

Material	No symbol	Carbon steel
	F	Stainless steel
Roller guide type	No symbol	Caged
	V	Full complement
Seal structure	No symbol	Shield type
	UU	Sealed type
Shape of outer ring	No symbol	Cylindrical outer ring
	R	Crowned outer ring

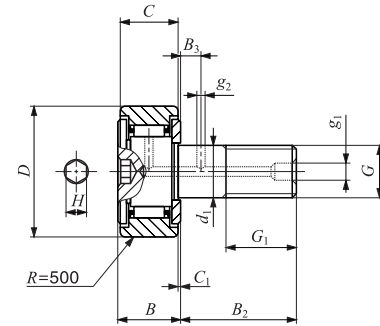

CR...BR

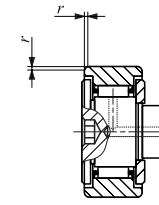

CR...B

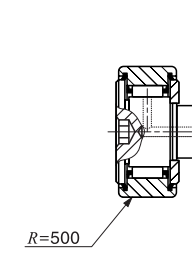

CR...BUUR

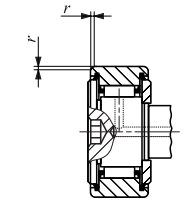

CR...BUU

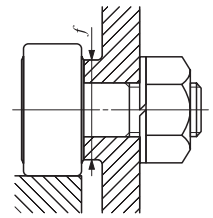

Stud dia. mm (inch)	Identification number				Mass (Ref.) g	Boundary dimensions mm(inch)				
	Shield type		Sealed type			D	C	d ₁	G UNF	G ₁
	With crowned outer ring	With cylindrical outer ring	With crowned outer ring	With cylindrical outer ring						
4.826 (¹ / ₁₆)	CR 8 BR	CR 8 B	CR 8 BUUR	CR 8 BUU	9	12.700 (¹ / ₂)	8.731 (¹¹ / ₃₂)	4.826	No.10-32	6.350 (¹ / ₄)
	CR 8-1 BR	CR 8-1 B	CR 8-1 BUUR	CR 8-1 BUU	10	12.700 (¹ / ₂)	9.525 (³ / ₈)	4.826	No.10-32	6.350 (¹ / ₄)
6.350 (¹ / ₄)	CR 10 BR	CR 10 B	CR 10 BUUR	CR 10 BUU	19	15.875 (⁵ / ₈)	10.319 (¹³ / ₃₂)	6.350 (¹ / ₄)	¹ / ₄ - 28	7.938 (⁵ / ₁₆)
	CR 10-1 BR	CR 10-1 B	CR 10-1 BUUR	CR 10-1 BUU	21	15.875 (⁵ / ₈)	11.112 (⁷ / ₁₆)	6.350 (¹ / ₄)	¹ / ₄ - 28	7.938 (⁵ / ₁₆)
9.525 (³ / ₈)	CR 12 BR	CR 12 B	CR 12 BUUR	CR 12 BUU	35	19.050 (³ / ₄)	12.700 (¹ / ₂)	9.525 (³ / ₈)	³ / ₈ - 24	9.525 (³ / ₈)
	CR 14 BR	CR 14 B	CR 14 BUUR	CR 14 BUU	46	22.225 (⁷ / ₈)	12.700 (¹ / ₂)	9.525 (³ / ₈)	³ / ₈ - 24	9.525 (³ / ₈)
11.112 (⁷ / ₁₆)	CR 16 BR	CR 16 B	CR 16 BUUR	CR 16 BUU	73	25.400 (1)	15.875 (⁵ / ₈)	11.112 (⁷ / ₁₆)	⁷ / ₁₆ - 20	12.700 (¹ / ₂)
	CR 18 BR	CR 18 B	CR 18 BUUR	CR 18 BUU	88	28.575 (1 ¹ / ₈)	15.875 (⁵ / ₈)	11.112 (⁷ / ₁₆)	⁷ / ₁₆ - 20	12.700 (¹ / ₂)
12.700 (¹ / ₂)	CR 20 BR	CR 20 B	CR 20 BUUR	CR 20 BUU	132	31.750 (1 ¹ / ₄)	19.050 (³ / ₄)	12.700 (¹ / ₂)	¹ / ₂ - 20	15.875 (⁵ / ₈)
	CR 22 BR	CR 22 B	CR 22 BUUR	CR 22 BUU	157	34.925 (1 ³ / ₈)	19.050 (³ / ₄)	12.700 (¹ / ₂)	¹ / ₂ - 20	15.875 (⁵ / ₈)
15.875 (⁵ / ₈)	CR 24 BR	CR 24 B	CR 24 BUUR	CR 24 BUU	225	38.100 (1 ¹ / ₂)	22.225 (⁷ / ₈)	15.875 (⁵ / ₈)	⁵ / ₈ - 18	19.050 (³ / ₄)
	CR 26 BR	CR 26 B	CR 26 BUUR	CR 26 BUU	260	41.275 (1 ³ / ₈)	22.225 (⁷ / ₈)	15.875 (⁵ / ₈)	⁵ / ₈ - 18	19.050 (³ / ₄)
19.050 (³ / ₄)	CR 28 BR	CR 28 B	CR 28 BUUR	CR 28 BUU	365	44.450 (1 ³ / ₄)	25.400 (1)	19.050 (³ / ₄)	³ / ₄ - 16	22.225 (⁷ / ₈)
	CR 30 BR	CR 30 B	CR 30 BUUR	CR 30 BUU	410	47.625 (1 ⁷ / ₈)	25.400 (1)	19.050 (³ / ₄)	³ / ₄ - 16	22.225 (⁷ / ₈)
22.225 (⁷ / ₈)	CR 32 BR	CR 32 B	CR 32 BUUR	CR 32 BUU	615	50.800 (2)	31.750 (1 ¹ / ₄)	22.225 (⁷ / ₈)	⁷ / ₈ - 14	25.400 (1)
	CR 36 BR	CR 36 B	CR 36 BUUR	CR 36 BUU	750	57.150 (2 ¹ / ₄)	31.750 (1 ¹ / ₄)	22.225 (⁷ / ₈)	⁷ / ₈ - 14	25.400 (1)

- Remarks1. Models with a stud diameter d_1 of 6.35 mm or less have no oil hole. Other models are provided with one oil hole each on the outside surface and end surface of the stud.
 2. Provided with prepacked grease.
 3. Eccentric Type Inch Series Cam Followers, CRE are also available. If required, please consult to IKO.
 4. A nut is supplied with the stud.

Boundary dimensions mm(inch)								Mounting dimension f mm(inch)	Maximum tightening torque N-m	Basic dynamic load rating C N	Basic static load rating C ₀ N
B max	B ₂	B ₃	C ₁	g ₁	g ₂	H	r				
10.2 (0.40)	12.700 (¹ / ₂)	— (—)	0.794 (¹ / ₃₂)	— (—)	— (—)	3.175 (¹ / ₈)	0.397 (¹ / ₆₄)	8.334 (²¹ / ₆₄)	1.4	2 520	2 140
10.9 (0.43)	15.875 (⁵ / ₈)	— (—)	0.794 (¹ / ₃₂)	— (—)	— (—)	3.175 (¹ / ₈)	0.397 (¹ / ₆₄)	8.334 (²¹ / ₆₄)	1.4	2 520	2 140
11.8 (0.46)	15.875 (⁵ / ₈)	— (—)	0.794 (¹ / ₃₂)	— (—)	— (—)	3.175 (¹ / ₈)	0.397 (¹ / ₆₄)	11.509 (²⁹ / ₆₄)	3.4	3 650	3 670
12.5 (0.49)	19.050 (³ / ₄)	— (—)	0.794 (¹ / ₃₂)	— (—)	— (—)	3.175 (¹ / ₈)	0.397 (¹ / ₆₄)	11.509 (²⁹ / ₆₄)	3.4	3 650	3 670
14.2 (0.56)	22.225 (⁷ / ₈)	6.350 (¹ / ₄)	0.794 (¹ / ₃₂)	4.762 (³ / ₁₆)	2.381 (³ / ₃₂)	4.762 (³ / ₁₆)	0.794 (¹ / ₃₂)	13.494 (¹⁷ / ₃₂)	10.8	4 420	5 110
14.2 (0.56)	22.225 (⁷ / ₈)	6.350 (¹ / ₄)	0.794 (¹ / ₃₂)	4.762 (³ / ₁₆)	2.381 (³ / ₃₂)	4.762 (³ / ₁₆)	0.794 (¹ / ₃₂)	15.081 (¹⁹ / ₃₂)	10.8	4 790	5 810
17.3 (0.68)	25.400 (1)	6.350 (¹ / ₄)	0.794 (¹ / ₃₂)	4.762 (³ / ₁₆)	3.175 (¹ / ₈)	6.350 (¹ / ₄)	1.191 (³ / ₆₄)	17.859 (⁴⁵ / ₆₄)	17.4	8 810	10 800
17.3 (0.68)	25.400 (1)	6.350 (¹ / ₄)	0.794 (¹ / ₃₂)	4.762 (³ / ₁₆)	3.175 (¹ / ₈)	6.350 (¹ / ₄)	1.588 (¹ / ₁₆)	19.050 (³ / ₄)	17.4	9 180	11 600
20.4 (0.80)	31.750 (1 ¹ / ₄)	7.938 (⁵ / ₁₆)	0.794 (¹ / ₃₂)	4.762 (³ / ₁₆)	3.175 (¹ / ₈)	6.350 (¹ / ₄)	1.588 (¹ / ₁₆)	21.828 (⁵⁵ / ₆₄)	27.7	14 200	16 000
20.4 (0.80)	31.750 (1 ¹ / ₄)	7.938 (⁵ / ₁₆)	0.794 (¹ / ₃₂)	4.762 (³ / ₁₆)	3.175 (¹ / ₈)	6.350 (¹ / ₄)	1.588 (¹ / ₁₆)	21.828 (⁵⁵ / ₆₄)	27.7	14 200	16 000
23.6 (0.93)	38.100 (1 ¹ / ₂)	9.525 (³ / ₈)	0.794 (¹ / ₃₂)	4.762 (³ / ₁₆)	3.969 (⁵ / ₃₂)	7.938 (⁵ / ₁₆)	1.588 (¹ / ₁₆)	26.196 (1 ¹ / ₁₆)	55.7	18 600	24 300
23.6 (0.93)	38.100 (1 ¹ / ₂)	9.525 (³ / ₈)	0.794 (¹ / ₃₂)	4.762 (³ / ₁₆)	3.969 (⁵ / ₃₂)	7.938 (⁵ / ₁₆)	1.588 (¹ / ₁₆)	26.196 (1 ¹ / ₁₆)	55.7	18 600	24 300
26.8 (1.06)	44.450 (1 ³ / ₄)	11.112 (⁷ / ₁₆)	0.794 (¹ / ₃₂)	4.762 (³ / ₁₆)	3.969 (⁵ / ₃₂)	7.938 (⁵ / ₁₆)	1.588 (¹ / ₁₆)	32.543 (1 ³ / ₃₂)	100	25 100	38 200
26.8 (1.06)	44.450 (1 ³ / ₄)	11.112 (⁷ / ₁₆)	0.794 (¹ / ₃₂)	4.762 (³ / ₁₆)	3.969 (⁵ / ₃₂)	7.938 (⁵ / ₁₆)	1.588 (¹ / ₁₆)	32.543 (1 ³ / ₃₂)	100	25 100	38 200
33.5 (1.32)	50.800 (2)	12.700 (¹ / ₂)	0.794 (¹ / ₃₂)	4.762 (³ / ₁₆)	4.762 (³ / ₁₆)	11.112 (⁷ / ₁₆)	1.588 (¹ / ₁₆)	37.306 (1 ¹⁵ / ₃₂)	162	32 500	63 900
33.5 (1.32)	50.800 (2)	12.700 (¹ / ₂)	0.794 (¹ / ₃₂)	4.762 (³ / ₁₆)	4.762 (³ / ₁₆)	11.112 (⁷ / ₁₆)	1.588 (¹ / ₁₆)	37.306 (1 ¹⁵ / ₃₂)	162	32 500	63 900

IKO Inch Series Cam Followers With Cage/With Screwdriver slot

Selectable product specifications

Material	No symbol	Carbon steel
	F	Stainless steel
Roller guide type	No symbol	Caged
	V	Full complement
Seal structure	No symbol	Shield type
	UU	Sealed type
Shape of outer ring	No symbol	Cylindrical outer ring
	R	Crowned outer ring

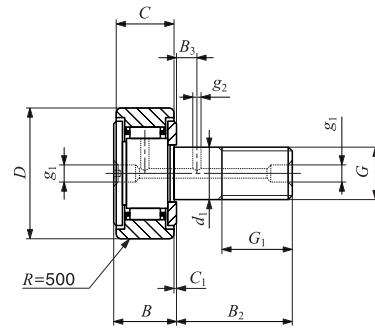

CR...R

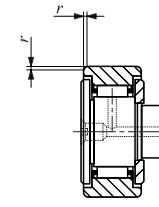

CR

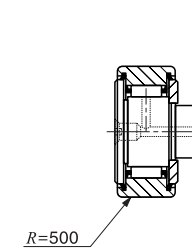

CR...UUR

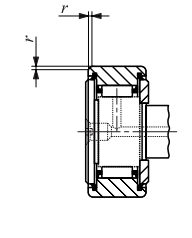

CR...UU

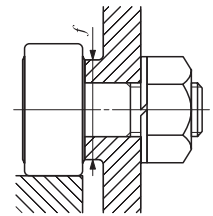

Stud dia. mm (inch)	Identification number				Mass (Ref.) g	Boundary dimensions mm(inch)					Mounting dimension f mm(inch)	Maximum tightening torque N-m	Basic dynamic load rating C N	Basic static load rating C ₀ N
	Shield type		Sealed type			D	C	d ₁	G UNF	G ₁				
	With crowned outer ring	With cylindrical outer ring	With crowned outer ring	With cylindrical outer ring										
4.826	CR 8 R	CR 8	CR 8 UUR	CR 8 UU	9	12.700 (1/2)	8.731 (11/32)	4.826	No.10-32	6.350 (1/4)	8.334 (21/64)	1.4	2 520	2 140
	CR 8-1 R	CR 8-1	CR 8-1 UUR	CR 8-1 UU	10	12.700 (1/2)	9.525 (3/8)	4.826	No.10-32	6.350 (1/4)				
6.350 (1/4)	CR 10 R	CR 10	CR 10 UUR	CR 10 UU	19	15.875 (5/8)	10.319 (13/32)	6.350 (1/4)	1/4 - 28	7.938 (5/16)	11.509 (29/64)	3.4	3 650	3 670
	CR 10-1 R	CR 10-1	CR 10-1 UUR	CR 10-1 UU	21	15.875 (5/8)	11.112 (7/16)	6.350 (1/4)	1/4 - 28	7.938 (5/16)				
9.525 (3/8)	CR 12 R	CR 12	CR 12 UUR	CR 12 UU	35	19.050 (3/4)	12.700 (1/2)	9.525 (3/8)	3/8 - 24	9.525 (3/8)	13.494 (17/32)	10.8	4 420	5 110
	CR 14 R	CR 14	CR 14 UUR	CR 14 UU	46	22.225 (7/8)	12.700 (1/2)	9.525 (3/8)	3/8 - 24	9.525 (3/8)				
11.112 (7/16)	CR 16 R	CR 16	CR 16 UUR	CR 16 UU	73	25.400 (1)	15.875 (5/8)	11.112 (7/16)	7/16 - 20	12.700 (1/2)	17.859 (45/64)	17.4	8 810	10 800
	CR 18 R	CR 18	CR 18 UUR	CR 18 UU	88	28.575 (1 1/8)	15.875 (5/8)	11.112 (7/16)	7/16 - 20	12.700 (1/2)				
12.700 (1/2)	CR 20 R	CR 20	CR 20 UUR	CR 20 UU	132	31.750 (1 1/4)	19.050 (3/4)	12.700 (1/2)	1/2 - 20	15.875 (5/8)	21.828 (55/64)	27.7	14 200	16 000
	CR 22 R	CR 22	CR 22 UUR	CR 22 UU	157	34.925 (1 3/8)	19.050 (3/4)	12.700 (1/2)	1/2 - 20	15.875 (5/8)				
15.875 (5/8)	CR 24 R	CR 24	CR 24 UUR	CR 24 UU	225	38.100 (1 1/2)	22.225 (7/8)	15.875 (5/8)	5/8 - 18	19.050 (3/4)	26.196 (1 1/64)	55.7	18 600	24 300
	CR 26 R	CR 26	CR 26 UUR	CR 26 UU	260	41.275 (1 5/8)	22.225 (7/8)	15.875 (5/8)	5/8 - 18	19.050 (3/4)				
19.050 (3/4)	CR 28 R	CR 28	CR 28 UUR	CR 28 UU	365	44.450 (1 3/4)	25.400 (1)	19.050 (3/4)	3/4 - 16	22.225 (7/8)	32.543 (1 1/32)	100	25 100	38 200
	CR 30 R	CR 30	CR 30 UUR	CR 30 UU	410	47.625 (1 7/8)	25.400 (1)	19.050 (3/4)	3/4 - 16	22.225 (7/8)				
22.225 (7/8)	CR 32 R	CR 32	CR 32 UUR	CR 32 UU	615	50.800 (2)	31.750 (1 1/4)	22.225 (7/8)	7/8 - 14	25.400 (1)	37.306 (1 15/32)	162	32 500	63 900
	CR 36 R	CR 36	CR 36 UUR	CR 36 UU	750	57.150 (2 1/4)	31.750 (1 1/4)	22.225 (7/8)	7/8 - 14	25.400 (1)				

- Remarks1. Models with a stud diameter d_1 of 6.35 mm or less (marked *) are provided with an oil hole on the stud head only. Other models are provided with one oil hole each on the head, outside surface and end surface of the stud.
 2. Provided with prepacked grease.
 3. Eccentric Type Inch Series Cam Followers, CRE are also available. If required, please consult to IKO.
 4. A nut is supplied with the stud.

Boundary dimensions mm(inch)							Mounting dimension f mm(inch)	Maximum tightening torque N-m	Basic dynamic load rating C N	Basic static load rating C ₀ N
B max	B ₂	B ₃	C ₁	g ₁	g ₂	r				
10.2 (0.40)	12.700 (1/2)	— (—)	0.794 (1/32)	*3.175 (1/8)	— (—)	0.397 (1/64)				
10.9 (0.43)	15.875 (5/8)	— (—)	0.794 (1/32)	*3.175 (1/8)	— (—)	0.397 (1/64)	8.334 (21/64)	1.4	2 520	2 140
11.8 (0.46)	15.875 (5/8)	— (—)	0.794 (1/32)	*3.175 (1/8)	— (—)	0.397 (1/64)	11.509 (29/64)	3.4	3 650	3 670
12.5 (0.49)	19.050 (3/4)	— (—)	0.794 (1/32)	*3.175 (1/8)	— (—)	0.397 (1/64)	11.509 (29/64)	3.4	3 650	3 670
14.2 (0.56)	22.225 (7/8)	6.350 (1/4)	0.794 (1/32)	4.762 (3/16)	2.381 (3/32)	0.794 (1/32)	13.494 (17/32)	10.8	4 420	5 110
14.2 (0.56)	22.225 (7/8)	6.350 (1/4)	0.794 (1/32)	4.762 (3/16)	2.381 (3/32)	0.794 (1/32)	15.081 (19/32)	10.8	4 790	5 810
17.3 (0.68)	25.400 (1)	6.350 (1/4)	0.794 (1/32)	4.762 (3/16)	3.175 (1/8)	1.191 (3/64)	17.859 (45/64)	17.4	8 810	10 800
17.3 (0.68)	25.400 (1)	6.350 (1/4)	0.794 (1/32)	4.762 (3/16)	3.175 (1/8)	1.588 (1/16)	19.050 (3/4)	17.4	9 180	11 600
20.4 (0.80)	31.750 (1 1/4)	7.938 (5/16)	0.794 (1/32)	4.762 (3/16)	3.175 (1/8)	1.588 (1/16)	21.828 (55/64)	27.7	14 200	16 000
20.4 (0.80)	31.750 (1 1/4)	7.938 (5/16)	0.794 (1/32)	4.762 (3/16)	3.175 (1/8)	1.588 (1/16)	21.828 (55/64)	27.7	14 200	16 000
23.6 (0.93)	38.100 (1 1/2)	9.525 (3/8)	0.794 (1/32)	4.762 (3/16)	3.969 (5/32)	1.588 (1/16)	26.196 (1 1/64)	55.7	18 600	24 300
23.6 (0.93)	38.100 (1 1/2)	9.525 (3/8)	0.794 (1/32)	4.762 (3/16)	3.969 (5/32)	1.588 (1/16)	26.196 (1 1/64)	55.7	18 600	24 300
26.8 (1.06)	44.450 (1 3/4)	11.112 (7/16)	0.794 (1/32)	4.762 (3/16)	3.969 (5/32)	1.588 (1/16)	32.543 (1 1/32)	100	25 100	38 200
26.8 (1.06)	44.450 (1 3/4)	11.112 (7/16)	0.794 (1/32)	4.762 (3/16)	3.969 (5/32)	1.588 (1/16)	32.543 (1 1/32)	100	25 100	38 200
33.5 (1.32)	50.800 (2)	12.700 (1/2)	0.794 (1/32)	4.762 (3/16)	4.762 (3/16)	1.588 (1/16)	37.306 (1 15/32)	162	32 500	63 900
33.5 (1.32)	50.800 (2)	12.700 (1/2)	0.794 (1/32)	4.762 (3/16)	4.762 (3/16)	1.588 (1/16)	37.306 (1 15/32)	162	32 500	63 900

IKO Inch Series Cam Followers Full Complement Type/With Hexagon Hole

Selectable product specifications

Material	No symbol	Carbon steel
	F	Stainless steel
Roller guide type	No symbol	Caged
	V	Full complement
Seal structure	No symbol	Shield type
	UU	Sealed type
Shape of outer ring	No symbol	Cylindrical outer ring
	R	Crowned outer ring

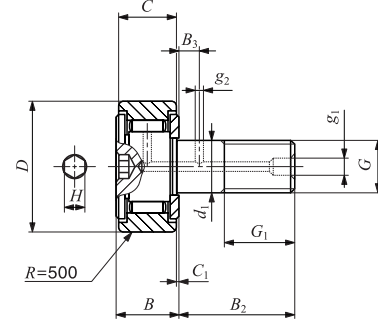

CR...VBR

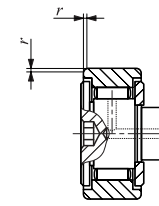

CR...VB

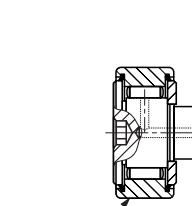

CR...VBUUR

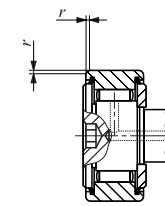

CR...VBUU

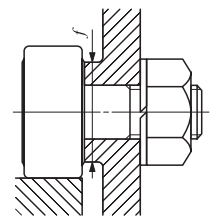

Stud dia. mm (inch)	Identification number				Mass (Ref.) g	D	C	d ₁	G UNF	G ₁
	Shield type		Sealed type							
	With crowned outer ring	With cylindrical outer ring	With crowned outer ring	With cylindrical outer ring						
4.826	CR 8 VBR	CR 8 VB	CR 8 VBUUR	CR 8 VBUU	9	12.700 (1/2)	8.731 (11/32)	4.826	No.10-32	6.350 (1/4)
	CR 8-1 VBR	CR 8-1VB	CR 8-1 VBUUR	CR 8-1 VBUU	10	12.700 (1/2)	9.525 (3/8)	4.826	No.10-32	6.350 (1/4)
6.350 (1/4)	CR 10 VBR	CR 10 VB	CR 10 VBUUR	CR 10 VBUU	19	15.875 (5/8)	10.319 (13/32)	6.350 (1/4)	1/4 - 28	7.938 (5/16)
	CR 10-1 VBR	CR 10-1VB	CR 10-1 VBUUR	CR 10-1 VBUU	21	15.875 (5/8)	11.112 (7/16)	6.350 (1/4)	1/4 - 28	7.938 (5/16)
9.525 (3/8)	CR 12 VBR	CR 12 VB	CR 12 VBUUR	CR 12 VBUU	36	19.050 (3/4)	12.700 (1/2)	9.525 (3/8)	3/8 - 24	9.525 (3/8)
	CR 14 VBR	CR 14 VB	CR 14 VBUUR	CR 14 VBUU	47	22.225 (7/8)	12.700 (1/2)	9.525 (3/8)	3/8 - 24	9.525 (3/8)
11.112 (7/16)	CR 16 VBR	CR 16 VB	CR 16 VBUUR	CR 16 VBUU	74	25.400 (1)	15.875 (5/8)	11.112 (7/16)	7/16 - 20	12.700 (1/2)
	CR 18 VBR	CR 18 VB	CR 18 VBUUR	CR 18 VBUU	85	28.575 (1 1/8)	15.875 (5/8)	11.112 (7/16)	7/16 - 20	12.700 (1/2)
12.700 (1/2)	CR 20 VBR	CR 20 VB	CR 20 VBUUR	CR 20 VBUU	137	31.750 (1 1/4)	19.050 (3/4)	12.700 (1/2)	1/2 - 20	15.875 (5/8)
	CR 22 VBR	CR 22 VB	CR 22 VBUUR	CR 22 VBUU	160	34.925 (1 3/8)	19.050 (3/4)	12.700 (1/2)	1/2 - 20	15.875 (5/8)
15.875 (5/8)	CR 24 VBR	CR 24 VB	CR 24 VBUUR	CR 24 VBUU	230	38.100 (1 1/2)	22.225 (7/8)	15.875 (5/8)	5/8 - 18	19.050 (3/4)
	CR 26 VBR	CR 26 VB	CR 26 VBUUR	CR 26 VBUU	265	41.275 (1 5/8)	22.225 (7/8)	15.875 (5/8)	5/8 - 18	19.050 (3/4)
19.050 (3/4)	CR 28 VBR	CR 28 VB	CR 28 VBUUR	CR 28 VBUU	372	44.450 (1 3/4)	25.400 (1)	19.050 (3/4)	3/4 - 16	22.225 (7/8)
	CR 30 VBR	CR 30 VB	CR 30 VBUUR	CR 30 VBUU	418	47.625 (1 7/8)	25.400 (1)	19.050 (3/4)	3/4 - 16	22.225 (7/8)
22.225 (7/8)	CR 32 VBR	CR 32 VB	CR 32 VBUUR	CR 32 VBUU	627	50.800 (2)	31.750 (1 1/4)	22.225 (7/8)	7/8 - 14	25.400 (1)
	CR 36 VBR	CR 36 VB	CR 36 VBUUR	CR 36 VBUU	759	57.150 (2 1/4)	31.750 (1 1/4)	22.225 (7/8)	7/8 - 14	25.400 (1)

- Remarks1. Models with a stud diameter d_1 of 6.35 mm or less have no oil hole. Other models are provided with one oil hole each on the outside surface and end surface of the stud.
 2. Provided with prepacked grease.
 3. Eccentric Type Inch Series Cam Followers, CRE are also available. If required, please consult to IKO.
 4. A nut is supplied with the stud.

Boundary dimensions mm(inch)								Mounting dimension f Min. mm(inch)	Maximum tightening torque N-m	Basic dynamic load rating C N	Basic static load rating C ₀ N
B max	B ₂	B ₃	C ₁	g ₁	g ₂	H	r				
10.2(0.40)	12.700(1/2)	— (—)	0.794(1/32)	— (—)	— (—)	3.175(1/8)	0.397(1/64)	8.334(21/64)	1.4	4 260	4 750
10.9(0.43)	15.875(5/8)	— (—)	0.794(1/32)	— (—)	— (—)	3.175(1/8)	0.397(1/64)	8.334(21/64)	1.4	4 710	5 410
11.8(0.46)	15.875(5/8)	— (—)	0.794(1/32)	— (—)	— (—)	3.175(1/8)	0.397(1/64)	11.509(29/64)	3.4	5 830	7 660
12.5(0.49)	19.050(3/4)	— (—)	0.794(1/32)	— (—)	— (—)	3.175(1/8)	0.397(1/64)	11.509(29/64)	3.4	6 340	8 530
14.2(0.56)	22.225(7/8)	6.350(1/4)	0.794(1/32)	4.762(3/16)	2.381(3/32)	4.762(3/16)	0.794(1/32)	13.494(17/32)	10.8	8 710	12 300
14.2(0.56)	22.225(7/8)	6.350(1/4)	0.794(1/32)	4.762(3/16)	2.381(3/32)	4.762(3/16)	0.794(1/32)	15.081(19/32)	10.8	8 710	12 300
17.3(0.68)	25.400(1)	6.350(1/4)	0.794(1/32)	4.762(3/16)	3.175(1/8)	6.350(1/4)	1.191(3/64)	17.859(45/64)	17.4	13 100	22 700
17.3(0.68)	25.400(1)	6.350(1/4)	0.794(1/32)	4.762(3/16)	3.175(1/8)	6.350(1/4)	1.588(1/16)	19.050(3/4)	17.4	13 100	22 700
20.4(0.80)	31.750(1 1/4)	7.938(5/16)	0.794(1/32)	4.762(3/16)	3.175(1/8)	6.350(1/4)	1.588(1/16)	21.828(55/64)	27.7	23 600	31 700
20.4(0.80)	31.750(1 1/4)	7.938(5/16)	0.794(1/32)	4.762(3/16)	3.175(1/8)	6.350(1/4)	1.588(1/16)	21.828(55/64)	27.7	23 600	31 700
23.6(0.93)	38.100(1 1/2)	9.525(3/8)	0.794(1/32)	4.762(3/16)	3.969(5/32)	7.938(5/16)	1.588(1/16)	26.196(1 1/64)	55.7	28 200	40 100
23.6(0.93)	38.100(1 1/2)	9.525(3/8)	0.794(1/32)	4.762(3/16)	3.969(5/32)	7.938(5/16)	1.588(1/16)	26.196(1 1/64)	55.7	28 200	40 100
26.8(1.06)	44.450(1 3/4)	11.112(7/16)	0.794(1/32)	4.762(3/16)	3.969(5/32)	7.938(5/16)	1.588(1/16)	32.543(1 9/32)	100	35 300	55 600
26.8(1.06)	44.450(1 3/4)	11.112(7/16)	0.794(1/32)	4.762(3/16)	3.969(5/32)	7.938(5/16)	1.588(1/16)	32.543(1 9/32)	100	35 300	55 600
33.5(1.32)	50.800(2)	12.700(1/2)	0.794(1/32)	4.762(3/16)	4.762(3/16)	11.112(7/16)	1.588(1/16)	37.306(1 13/32)	162	45 700	80 600
33.5(1.32)	50.800(2)	12.700(1/2)	0.794(1/32)	4.762(3/16)	4.762(3/16)	11.112(7/16)	1.588(1/16)	37.306(1 13/32)	162	45 700	80 600

IKO Inch Series Cam Followers Full Complement Type/With Screwdriver Slot

Selectable product specifications

Material	No symbol	Carbon steel
	F	Stainless steel
Roller guide type	No symbol	Caged
	V	Full complement
Seal structure	No symbol	Shield type
	UU	Sealed type
Shape of outer ring	No symbol	Cylindrical outer ring
	R	Crowned outer ring

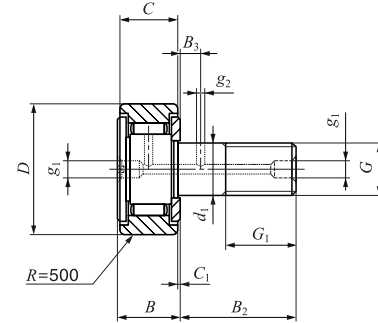

CR...VR

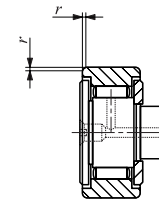

CR...V

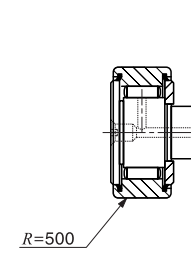

CR...VUUR

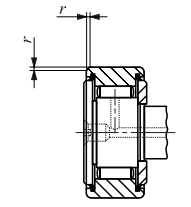

CR...VUU

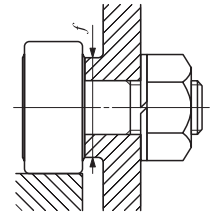

Stud dia. mm (inch)	Identification number				Mass (Ref.) g	D	C	d ₁	G UNF	G ₁
	Shield type		Sealed type							
	With crowned outer ring	With cylindrical outer ring	With crowned outer ring	With cylindrical outer ring						
4.826	CR 8 VR	CR 8 V	CR 8 VUUR	CR 8 VUU	9	12.700 (1/2)	8.731 (11/32)	4.826	No.10-32	6.350 (1/4)
	CR 8-1 VR	CR 8-1 V	CR 8-1 VUUR	CR 8-1 VUU	10	12.700 (1/2)	9.525 (3/8)	4.826	No.10-32	6.350 (1/4)
6.350 (1/4)	CR 10 VR	CR 10 V	CR 10 VUUR	CR 10 VUU	19	15.875 (5/8)	10.319 (13/32)	6.350 (1/4)	1/4 - 28	7.938 (5/16)
	CR 10-1 VR	CR 10-1 V	CR 10-1 VUUR	CR 10-1 VUU	21	15.875 (5/8)	11.112 (7/16)	6.350 (1/4)	1/4 - 28	7.938 (5/16)
9.525 (3/8)	CR 12 VR	CR 12 V	CR 12 VUUR	CR 12 VUU	36	19.050 (3/4)	12.700 (1/2)	9.525 (3/8)	3/8 - 24	9.525 (3/8)
	CR 14 VR	CR 14 V	CR 14 VUUR	CR 14 VUU	47	22.225 (7/8)	12.700 (1/2)	9.525 (3/8)	3/8 - 24	9.525 (3/8)
11.112 (7/16)	CR 16 VR	CR 16 V	CR 16 VUUR	CR 16 VUU	74	25.400 (1)	15.875 (5/8)	11.112 (7/16)	7/16 - 20	12.700 (1/2)
	CR 18 VR	CR 18 V	CR 18 VUUR	CR 18 VUU	85	28.575 (1 1/8)	15.875 (5/8)	11.112 (7/16)	7/16 - 20	12.700 (1/2)
12.700 (1/2)	CR 20 VR	CR 20 V	CR 20 VUUR	CR 20 VUU	137	31.750 (1 1/4)	19.050 (3/4)	12.700 (1/2)	1/2 - 20	15.875 (5/8)
	CR 22 VR	CR 22 V	CR 22 VUUR	CR 22 VUU	160	34.925 (1 3/8)	19.050 (3/4)	12.700 (1/2)	1/2 - 20	15.875 (5/8)
15.875 (5/8)	CR 24 VR	CR 24 V	CR 24 VUUR	CR 24 VUU	230	38.100 (1 1/2)	22.225 (7/8)	15.875 (5/8)	5/8 - 18	19.050 (3/4)
	CR 26 VR	CR 26 V	CR 26 VUUR	CR 26 VUU	265	41.275 (1 5/8)	22.225 (7/8)	15.875 (5/8)	5/8 - 18	19.050 (3/4)
19.050 (3/4)	CR 28 VR	CR 28 V	CR 28 VUUR	CR 28 VUU	372	44.450 (1 3/4)	25.400 (1)	19.050 (3/4)	3/4 - 16	22.225 (7/8)
	CR 30 VR	CR 30 V	CR 30 VUUR	CR 30 VUU	418	47.625 (1 7/8)	25.400 (1)	19.050 (3/4)	3/4 - 16	22.225 (7/8)
22.225 (7/8)	CR 32 VR	CR 32 V	CR 32 VUUR	CR 32 VUU	627	50.800 (2)	31.750 (1 1/4)	22.225 (7/8)	7/8 - 14	25.400 (1)
	CR 36 VR	CR 36 V	CR 36 VUUR	CR 36 VUU	759	57.150 (2 1/4)	31.750 (1 1/4)	22.225 (7/8)	7/8 - 14	25.400 (1)
31.750 (1 1/4)	—	—	—	CR 48 VUU	1960	76.200 (3)	44.450 (1 3/4)	31.750 (1 1/4)	1 1/4 - 12	31.750 (1 1/4)

Remarks1. Models with a stud diameter d_1 of 6.35 mm or less (marked *) are provided with an oil hole on the stud head only. Other models are provided with one oil hole each on the head, outside surface and end surface of the stud.
 2. Provided with prepacked grease.
 3. Eccentric Type Inch Series Cam Followers, CRE are also available. If required, please consult to IKO.

Boundary dimensions mm(inch)							Mounting dimension f Min. mm(inch)	Maximum tightening torque N-m	Basic dynamic load rating C N	Basic static load rating C ₀ N
B max	B ₂	B ₃	C ₁	g ₁	g ₂	r				
10.2 (0.40)	12.700 (1/2)	— (—)	0.794 (1/32)	*3.175 (1/8)	— (—)	0.397 (1/64)	8.334 (21/64)	1.4	4 260	4 750
10.9 (0.43)	15.875 (5/8)	— (—)	0.794 (1/32)	*3.175 (1/8)	— (—)	0.397 (1/64)	8.334 (21/64)	1.4	4 710	5 410
11.8 (0.46)	15.875 (5/8)	— (—)	0.794 (1/32)	*3.175 (1/8)	— (—)	0.397 (1/64)	11.509 (29/64)	3.4	5 830	7 660
12.5 (0.49)	19.050 (3/4)	— (—)	0.794 (1/32)	*3.175 (1/8)	— (—)	0.397 (1/64)	11.509 (29/64)	3.4	6 340	8 530
14.2 (0.56)	22.225 (7/8)	6.350 (1/4)	0.794 (1/32)	4.762 (3/16)	2.381 (3/32)	0.794 (1/32)	13.494 (17/32)	10.8	8 710	12 300
14.2 (0.56)	22.225 (7/8)	6.350 (1/4)	0.794 (1/32)	4.762 (3/16)	2.381 (3/32)	0.794 (1/32)	15.081 (19/32)	10.8	8 710	12 300
17.3 (0.68)	25.400 (1)	6.350 (1/4)	0.794 (1/32)	4.762 (3/16)	3.175 (1/8)	1.191 (3/64)	17.859 (45/64)	17.4	13 100	22 700
17.3 (0.68)	25.400 (1)	6.350 (1/4)	0.794 (1/32)	4.762 (3/16)	3.175 (1/8)	1.588 (1/16)	19.050 (3/4)	17.4	13 100	22 700
20.4 (0.80)	31.750 (1 1/4)	7.938 (5/16)	0.794 (1/32)	4.762 (3/16)	3.175 (1/8)	1.588 (1/16)	21.828 (55/64)	27.7	23 600	31 700
20.4 (0.80)	31.750 (1 1/4)	7.938 (5/16)	0.794 (1/32)	4.762 (3/16)	3.175 (1/8)	1.588 (1/16)	21.828 (55/64)	27.7	23 600	31 700
23.6 (0.93)	38.100 (1 1/2)	9.525 (3/8)	0.794 (1/32)	4.762 (3/16)	3.969 (3/32)	1.588 (1/16)	26.196 (1 3/64)	55.7	28 200	40 100
23.6 (0.93)	38.100 (1 1/2)	9.525 (3/8)	0.794 (1/32)	4.762 (3/16)	3.969 (3/32)	1.588 (1/16)	26.196 (1 3/64)	55.7	28 200	40 100
26.8 (1.06)	44.450 (1 3/4)	11.112 (7/16)	0.794 (1/32)	4.762 (3/16)	3.969 (3/32)	1.588 (1/16)	32.543 (1 1/32)	100	35 300	55 600
26.8 (1.06)	44.450 (1 3/4)	11.112 (7/16)	0.794 (1/32)	4.762 (3/16)	3.969 (3/32)	1.588 (1/16)	32.543 (1 1/32)	100	35 300	55 600
33.5 (1.32)	50.800 (2)	12.700 (1/2)	0.794 (1/32)	4.762 (3/16)	4.762 (3/16)	1.588 (1/16)	37.306 (1 15/32)	162	45 700	80 600
33.5 (1.32)	50.800 (2)	12.700 (1/2)	0.794 (1/32)	4.762 (3/16)	4.762 (3/16)	1.588 (1/16)	37.306 (1 15/32)	162	45 700	80 600
46.4 (1.83)	63.500 (2 1/2)	15.875 (5/8)	1.588 (1/16)	6.350 (1/4)	4.762 (3/16)	2.381 (3/32)	51.991 (2 3/64)	500	77 600	172 000

IKO Inch Series Heavy Duty Cam Followers Full Complement Type/With Hexagon Hole

Selectable product specifications

Material	No symbol	Carbon steel
	F	Stainless steel
Roller guide type	No symbol	Caged
	V	Full complement
Seal structure	No symbol	Shield type
	UU	Sealed type
Shape of outer ring	No symbol	Cylindrical outer ring
	R	Crowned outer ring

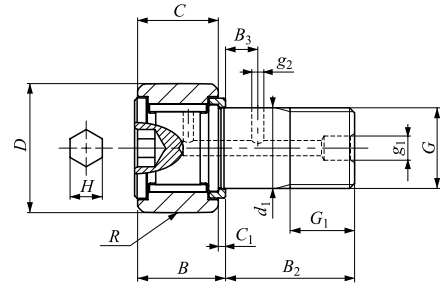

CRH...VBR

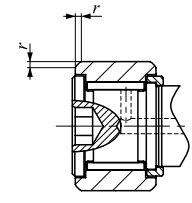

CRH...VB

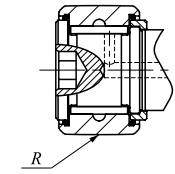

CRH...VBUUR

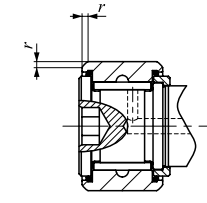

CRH...VBUU

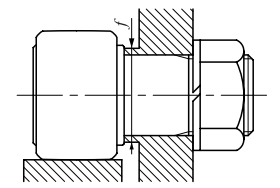

Stud dia. mm (inch)	Identification number				Mass (Ref.) g	D	C	d ₁	G UNF	G ₁
	Shield type		Sealed type							
	With crowned outer ring	With cylindrical outer ring	With crowned outer ring	With cylindrical outer ring						
6.350 (1/4)	CRH 8-1 VBR	CRH 8-1 VB	CRH 8-1 VBUUR	CRH 8-1 VBUU	12	12.700 (1/2)	9.525 (3/8)	6.350 (1/4)	1/4-28	6.350 (1/4)
	CRH 9 VBR	CRH 9 VB	CRH 9 VBUUR	CRH 9 VBUU	15	14.288 (9/16)	9.525 (3/8)	6.350 (1/4)	1/4-28	6.350 (1/4)
7.938 (5/16)	CRH 10-1 VBR	CRH 10-1 VB	CRH 10-1 VBUUR	CRH 10-1 VBUU	23	15.875 (5/8)	11.112 (7/16)	7.938 (5/16)	5/16-24	7.938 (5/16)
	CRH 11 VBR	CRH 11 VB	CRH 11 VBUUR	CRH 11 VBUU	27	17.462 (11/16)	11.112 (7/16)	7.938 (5/16)	5/16-24	7.938 (5/16)
11.112 (7/16)	CRH 12 VBR	CRH 12 VB	CRH 12 VBUUR	CRH 12 VBUU	39	19.050 (3/4)	12.700 (1/2)	11.112 (7/16)	7/16-20	9.525 (3/8)
	CRH 14 VBR	CRH 14 VB	CRH 14 VBUUR	CRH 14 VBUU	49	22.225 (7/8)	12.700 (1/2)	11.112 (7/16)	7/16-20	9.525 (3/8)
15.875 (5/8)	CRH 16 VBR	CRH 16 VB	CRH 16 VBUUR	CRH 16 VBUU	93	25.400 (1)	15.875 (5/8)	15.875 (5/8)	5/8-18	12.700 (1/2)
	CRH 18 VBR	CRH 18 VB	CRH 18 VBUUR	CRH 18 VBUU	109	28.575 (1 1/8)	15.875 (5/8)	15.875 (5/8)	5/8-18	12.700 (1/2)
19.050 (3/4)	CRH 20 VBR	CRH 20 VB	CRH 20 VBUUR	CRH 20 VBUU	176	31.750 (1 1/4)	19.050 (3/4)	19.050 (3/4)	3/4-16	15.875 (5/8)
	CRH 22 VBR	CRH 22 VB	CRH 22 VBUUR	CRH 22 VBUU	200	34.925 (1 3/8)	19.050 (3/4)	19.050 (3/4)	3/4-16	15.875 (5/8)
22.225 (7/8)	CRH 24 VBR	CRH 24 VB	CRH 24 VBUUR	CRH 24 VBUU	296	38.100 (1 1/2)	22.225 (7/8)	22.225 (7/8)	7/8-14	19.050 (3/4)
	CRH 26 VBR	CRH 26 VB	CRH 26 VBUUR	CRH 26 VBUU	329	41.275 (1 5/8)	22.225 (7/8)	22.225 (7/8)	7/8-14	19.050 (3/4)
25.400 (1)	CRH 28 VBR	CRH 28 VB	CRH 28 VBUUR	CRH 28 VBUU	463	44.450 (1 3/4)	25.400 (1)	25.400 (1)	1-14 UNS	22.225 (7/8)
	CRH 30 VBR	CRH 30 VB	CRH 30 VBUUR	CRH 30 VBUU	508	47.625 (1 7/8)	25.400 (1)	25.400 (1)	1-14 UNS	22.225 (7/8)
28.575 (1 1/8)	CRH 32 VBR	CRH 32 VB	CRH 32 VBUUR	CRH 32 VBUU	722	50.800 (2)	31.750 (1 1/4)	28.575 (1 1/8)	1 1/8-12	25.400 (1)
	CRH 36 VBR	CRH 36 VB	CRH 36 VBUUR	CRH 36 VBUU	858	57.150 (2 1/4)	31.750 (1 1/4)	28.575 (1 1/8)	1 1/8-12	25.400 (1)
31.750 (1 1/4)	CRH 40 VBR	CRH 40 VB	CRH 40 VBUUR	CRH 40 VBUU	1 260	63.500 (2 1/2)	38.100 (1 1/2)	31.750 (1 1/4)	1 1/4-12	28.575 (1 1/8)
	CRH 44 VBR	CRH 44 VB	CRH 44 VBUUR	CRH 44 VBUU	1 460	69.850 (2 3/4)	38.100 (1 1/2)	31.750 (1 1/4)	1 1/4-12	28.575 (1 1/8)
38.100 (1 1/2)	CRH 48 VBR	CRH 48 VB	CRH 48 VBUUR	CRH 48 VBUU	2 100	76.200 (3)	44.450 (1 3/4)	38.100 (1 1/2)	1 1/2-12	31.750 (1 1/4)
	CRH 52 VBR	CRH 52 VB	CRH 52 VBUUR	CRH 52 VBUU	2 380	82.550 (3 1/4)	44.450 (1 3/4)	38.100 (1 1/2)	1 1/2-12	31.750 (1 1/4)
44.450 (1 3/4)	CRH 56 VBR	CRH 56 VB	CRH 56 VBUUR	CRH 56 VBUU	3 240	88.900 (3 1/2)	50.800 (2)	44.450 (1 3/4)	1 3/4-12 UN	34.925 (1 3/8)
50.800 (2)	CRH 64 VBR	CRH 64 VB	CRH 64 VBUUR	CRH 64 VBUU	4 960	101.600 (4)	57.150 (2 1/4)	50.800 (2)	2-12 UN	38.100 (1 1/2)

Remarks1. Models with a stud diameter d_1 of 7.938 mm or less have no oil hole. Other models are provided with one oil hole each on the outside surface and end surface of the stud.
 2. Provided with prepacked grease.
 3. A nut is supplied with the stud.

Boundary dimensions mm(inch)									Mounting dimension f Min. mm(inch)	Maximum tightening torque N-m	Basic dynamic load rating C N	Basic static load rating C ₀ N
B max	B ₂	B ₃	C ₁	g ₁	g ₂	H	R	r				
11.1(0.44)	15.875(5/8)	— (-)	0.794(1/2)	— (-)	— (-)	3.175(1/8)	180(7)	0.397(1/64)	8.334(1/6)	3.4	4 710	5 410
11.1(0.44)	15.875(5/8)	— (-)	0.794(1/2)	— (-)	— (-)	3.175(1/8)	180(7)	0.397(1/64)	8.334(1/6)	3.4	4 710	5 410
12.8(0.50)	19.050(3/4)	— (-)	0.794(1/2)	— (-)	— (-)	3.175(1/8)	200(8)	0.397(1/64)	11.112(7/16)	6.8	6 340	8 530
12.8(0.50)	19.050(3/4)	— (-)	0.794(1/2)	— (-)	— (-)	3.175(1/8)	200(8)	0.397(1/64)	11.112(7/16)	6.8	6 340	8 530
14.6(0.57)	22.225(7/8)	6.350(1/4)	0.794(1/2)	4.762(3/16)	2.381(3/32)	4.762(3/16)	250(10)	0.794(1/32)	13.494(1/2)	17.6	8 710	12 300
14.6(0.57)	22.225(7/8)	6.350(1/4)	0.794(1/2)	4.762(3/16)	2.381(3/32)	4.762(3/16)	250(10)	0.794(1/32)	13.494(1/2)	17.6	8 710	12 300
17.9(0.70)	25.400(1)	6.350(1/4)	1.588(1/8)	4.762(3/16)	2.381(3/32)	6.350(1/4)	300(12)	1.191(1/64)	18.256(3/2)	57.8	13 100	22 700
17.9(0.70)	25.400(1)	6.350(1/4)	1.588(1/8)	4.762(3/16)	2.381(3/32)	6.350(1/4)	300(12)	1.588(1/16)	18.256(3/2)	57.8	13 100	22 700
21.0(0.83)	31.750(1 1/4)	7.938(5/16)	1.588(1/8)	4.762(3/16)	2.381(3/32)	6.350(1/4)	360(14)	1.588(1/16)	24.209(9/16)	103	23 600	31 700
21.0(0.83)	31.750(1 1/4)	7.938(5/16)	1.588(1/8)	4.762(3/16)	2.381(3/32)	6.350(1/4)	360(14)	1.588(1/16)	24.209(9/16)	103	23 600	31 700
24.3(0.96)	38.100(1 1/2)	9.525(3/8)	1.588(1/8)	4.762(3/16)	2.381(3/32)	7.938(5/16)	500(20)	1.588(1/16)	26.988(1 1/16)	162	28 200	40 100
24.3(0.96)	38.100(1 1/2)	9.525(3/8)	1.588(1/8)	4.762(3/16)	2.381(3/32)	7.938(5/16)	500(20)	1.588(1/16)	26.988(1 1/16)	162	28 200	40 100
27.4(1.08)	44.450(1 3/4)	11.112(7/16)	1.588(1/8)	4.762(3/16)	2.381(3/32)	7.938(5/16)	500(20)	1.588(1/16)	32.941(1 1/16)	258	35 300	55 600
27.4(1.08)	44.450(1 3/4)	11.112(7/16)	1.588(1/8)	4.762(3/16)	2.381(3/32)	7.938(5/16)	500(20)	1.588(1/16)	32.941(1 1/16)	258	35 300	55 600
34.2(1.35)	50.800(2)	12.700(1/2)	1.588(1/8)	4.762(3/16)	3.175(1/8)	11.112(7/16)	600(24)	1.588(1/16)	37.306(1 1/2)	356	45 700	80 600
34.2(1.35)	50.800(2)	12.700(1/2)	1.588(1/8)	4.762(3/16)	3.175(1/8)	11.112(7/16)	600(24)	1.588(1/16)	37.306(1 1/2)	356	45 700	80 600
40.0(1.57)	57.150(2 1/4)	14.288(9/16)	1.588(1/8)	4.762(3/16)	3.175(1/8)	12.700(1/2)	760(30)	2.381(3/32)	40.878(1 3/16)	500	61 400	116 000
40.0(1.57)	57.150(2 1/4)	14.288(9/16)	1.588(1/8)	4.762(3/16)	3.175(1/8)	12.700(1/2)	760(30)	2.381(3/32)	40.878(1 3/16)	500	61 400	116 000
46.4(1.83)	63.500(2 1/2)	15.875(5/8)	1.588(1/8)	6.350(1/4)	3.175(1/8)	19.050(3/4)	760(30)	2.381(3/32)	51.991(2 1/16)	892	77 600	172 000
46.4(1.83)	63.500(2 1/2)	15.875(5/8)	1.588(1/8)	6.350(1/4)	3.175(1/8)	19.050(3/4)	760(30)	2.381(3/32)	51.991(2 1/16)	892	77 600	172 000
52.8(2.08)	69.850(2 3/4)	17.462(11/16)	1.588(1/8)	6.350(1/4)	3.175(1/8)	19.050(3/4)	760(30)	2.381(3/32)	59.928(2 3/16)	1 450	111 000	239 000
59.4(2.34)	88.900(3 1/2)	19.050(3/4)	1.588(1/8)	6.350(1/4)	3.175(1/8)	19.050(3/4)	760(30)	2.381(3/32)	64.691(2 5/16)	2 190	142 000	317 000

IKO Inch Series Heavy Duty Cam Followers Full Complement Type/With Hexagon Hole

Selectable product specifications

Material	No symbol	Carbon steel
	F	Stainless steel
Roller guide type	No symbol	Caged
	V	Full complement
Seal structure	No symbol	Shield type
	UU	Sealed type
Shape of outer ring	No symbol	Cylindrical outer ring
	R	Crowned outer ring

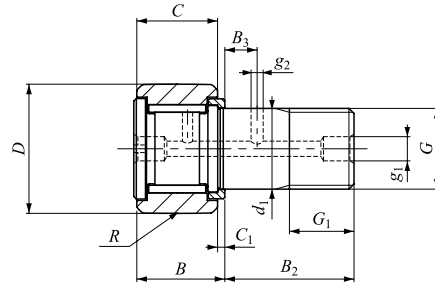

CRH...VR

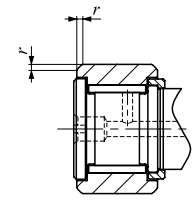

CRH...V

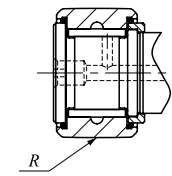

CRH...VUUR

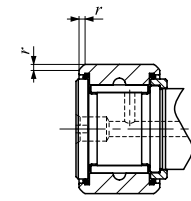

CRH...VUU

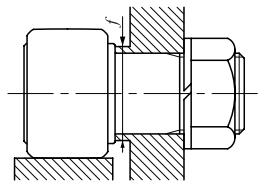

Stud dia. mm (inch)	Identification number				Mass (Ref.) g	D	C	d ₁	G UNF	G ₁
	Shield type		Sealed type							
	With crowned outer ring	With cylindrical outer ring	With crowned outer ring	With cylindrical outer ring						
6.350 (1/4)	CRH 8-1 VR	CRH 8-1 V	CRH 8-1 VUUR	CRH 8-1 VUU	12	12.700 (1/2)	9.525 (3/8)	6.350 (1/4)	1/4-28	6.350 (1/4)
	CRH 9 VR	CRH 9 V	CRH 9 VUUR	CRH 9 VUU	15	14.288 (9/16)	9.525 (3/8)	6.350 (1/4)	1/4-28	6.350 (1/4)
7.938 (5/16)	CRH 10-1 VR	CRH 10-1 V	CRH 10-1 VUUR	CRH 10-1 VUU	23	15.875 (5/8)	11.112 (7/16)	7.938 (5/16)	5/16-24	7.938 (5/16)
	CRH 11 VR	CRH 11 V	CRH 11 VUUR	CRH 11 VUU	27	17.462 (11/16)	11.112 (7/16)	7.938 (5/16)	5/16-24	7.938 (5/16)
11.112 (7/16)	CRH 12 VR	CRH 12 V	CRH 12 VUUR	CRH 12 VUU	39	19.050 (3/4)	12.700 (1/2)	11.112 (7/16)	7/16-20	9.525 (3/8)
	CRH 14 VR	CRH 14 V	CRH 14 VUUR	CRH 14 VUU	49	22.225 (7/8)	12.700 (1/2)	11.112 (7/16)	7/16-20	9.525 (3/8)
15.875 (5/8)	CRH 16 VR	CRH 16 V	CRH 16 VUUR	CRH 16 VUU	93	25.400 (1)	15.875 (5/8)	15.875 (5/8)	5/8-18	12.700 (1/2)
	CRH 18 VR	CRH 18 V	CRH 18 VUUR	CRH 18 VUU	109	28.575 (1 1/8)	15.875 (5/8)	15.875 (5/8)	5/8-18	12.700 (1/2)
19.050 (3/4)	CRH 20 VR	CRH 20 V	CRH 20 VUUR	CRH 20 VUU	176	31.750 (1 1/4)	19.050 (3/4)	19.050 (3/4)	3/4-16	15.875 (5/8)
	CRH 22 VR	CRH 22 V	CRH 22 VUUR	CRH 22 VUU	200	34.925 (1 3/8)	19.050 (3/4)	19.050 (3/4)	3/4-16	15.875 (5/8)
22.225 (7/8)	CRH 24 VR	CRH 24 V	CRH 24 VUUR	CRH 24 VUU	296	38.100 (1 1/2)	22.225 (7/8)	22.225 (7/8)	7/8-14	19.050 (3/4)
	CRH 26 VR	CRH 26 V	CRH 26 VUUR	CRH 26 VUU	329	41.275 (1 5/8)	22.225 (7/8)	22.225 (7/8)	7/8-14	19.050 (3/4)
25.400 (1)	CRH 28 VR	CRH 28 V	CRH 28 VUUR	CRH 28 VUU	463	44.450 (1 3/4)	25.400 (1)	25.400 (1)	1-14 UNS	22.225 (7/8)
	CRH 30 VR	CRH 30 V	CRH 30 VUUR	CRH 30 VUU	508	47.625 (1 7/8)	25.400 (1)	25.400 (1)	1-14 UNS	22.225 (7/8)
28.575 (1 1/8)	CRH 32 VR	CRH 32 V	CRH 32 VUUR	CRH 32 VUU	722	50.800 (2)	31.750 (1 1/4)	28.575 (1 1/8)	1 1/8-12	25.400 (1)
	CRH 36 VR	CRH 36 V	CRH 36 VUUR	CRH 36 VUU	858	57.150 (2 1/4)	31.750 (1 1/4)	28.575 (1 1/8)	1 1/8-12	25.400 (1)
31.750 (1 1/4)	CRH 40 VR	CRH 40 V	CRH 40 VUUR	CRH 40 VUU	1 260	63.500 (2 1/2)	38.100 (1 1/2)	31.750 (1 1/4)	1 1/4-12	28.575 (1 1/8)
	CRH 44 VR	CRH 44 V	CRH 44 VUUR	CRH 44 VUU	1 460	69.850 (2 3/4)	38.100 (1 1/2)	31.750 (1 1/4)	1 1/4-12	28.575 (1 1/8)
38.100 (1 1/2)	CRH 48 VR	CRH 48 V	CRH 48 VUUR	CRH 48 VUU	2 100	76.200 (3)	44.450 (1 3/4)	38.100 (1 1/2)	1 1/2-12	31.750 (1 1/4)
	CRH 52 VR	CRH 52 V	CRH 52 VUUR	CRH 52 VUU	2 380	82.550 (3 1/4)	44.450 (1 3/4)	38.100 (1 1/2)	1 1/2-12	31.750 (1 1/4)
44.450 (1 3/4)	CRH 56 VR	CRH 56 V	CRH 56 VUUR	CRH 56 VUU	3 240	88.900 (3 1/2)	50.800 (2)	44.450 (1 3/4)	1 3/4-12 UN	34.925 (1 3/8)
	CRH 64 VR	CRH 64 V	CRH 64 VUUR	CRH 64 VUU	4 960	101.600 (4)	57.150 (2 1/4)	50.800 (2)	2-12 UN	38.100 (1 1/2)

Remarks1. Models with a stud diameter d_1 of 7.938 mm or less (marked *) are provided with an oil hole on the stud head only. Other models are provided with one oil hole each on the head, outside surface and end surface of the stud.
 2. Provided with prepacked grease.
 3. A nut is supplied with the stud.

Boundary dimensions mm(inch)								Mounting dimension f Min. mm(inch)	Maximum tightening torque N-m	Basic dynamic load rating C N	Basic static load rating C ₀ N
B max	B ₂	B ₃	C ₁	g ₁	g ₂	R	r				
11.1(0.44)	15.875(5/8)	— (—)	0.794(1/32)	*3.175(1/8)	— (—)	180(7)	0.397(1/64)	8.334(21/64)	3.4	4 710	5 410
11.1(0.44)	15.875(5/8)	— (—)	0.794(1/32)	*3.175(1/8)	— (—)	180(7)	0.397(1/64)	8.334(21/64)	3.4	4 710	5 410
12.8(0.50)	19.050(3/4)	— (—)	0.794(1/32)	*3.175(1/8)	— (—)	200(8)	0.397(1/64)	11.112(7/16)	6.8	6 340	8 530
12.8(0.50)	19.050(3/4)	— (—)	0.794(1/32)	*3.175(1/8)	— (—)	200(8)	0.397(1/64)	11.112(7/16)	6.8	6 340	8 530
14.6(0.57)	22.225(7/8)	6.350(1/4)	0.794(1/32)	4.762(3/16)	2.381(3/32)	250(10)	0.794(1/32)	13.494(17/32)	17.6	8 710	12 300
14.6(0.57)	22.225(7/8)	6.350(1/4)	0.794(1/32)	4.762(3/16)	2.381(3/32)	250(10)	0.794(1/32)	13.494(17/32)	17.6	8 710	12 300
17.9(0.70)	25.400(1)	6.350(1/4)	1.588(1/16)	4.762(3/16)	2.381(3/32)	300(12)	1.191(3/64)	18.256(23/32)	57.8	13 100	22 700
17.9(0.70)	25.400(1)	6.350(1/4)	1.588(1/16)	4.762(3/16)	2.381(3/32)	300(12)	1.588(1/16)	18.256(23/32)	57.8	13 100	22 700
21.0(0.83)	31.750(1 1/4)	7.938(5/16)	1.588(1/16)	4.762(3/16)	2.381(3/32)	360(14)	1.588(1/16)	24.209(61/64)	103	23 600	31 700
21.0(0.83)	31.750(1 1/4)	7.938(5/16)	1.588(1/16)	4.762(3/16)	2.381(3/32)	360(14)	1.588(1/16)	24.209(61/64)	103	23 600	31 700
24.3(0.96)	38.100(1 1/2)	9.525(3/8)	1.588(1/16)	4.762(3/16)	2.381(3/32)	500(20)	1.588(1/16)	26.988(1 1/16)	162	28 200	40 100
24.3(0.96)	38.100(1 1/2)	9.525(3/8)	1.588(1/16)	4.762(3/16)	2.381(3/32)	500(20)	1.588(1/16)	26.988(1 1/16)	162	28 200	40 100
27.4(1.08)	44.450(1 3/4)	11.112(7/16)	1.588(1/16)	4.762(3/16)	2.381(3/32)	500(20)	1.588(1/16)	32.941(1 15/64)	258	35 300	55 600
27.4(1.08)	44.450(1 3/4)	11.112(7/16)	1.588(1/16)	4.762(3/16)	2.381(3/32)	500(20)	1.588(1/16)	32.941(1 15/64)	258	35 300	55 600
34.2(1.35)	50.800(2)	12.700(1/2)	1.588(1/16)	4.762(3/16)	3.175(1/8)	600(24)	1.588(1/16)	37.306(1 15/32)	356	45 700	80 600
34.2(1.35)	50.800(2)	12.700(1/2)	1.588(1/16)	4.762(3/16)	3.175(1/8)	600(24)	1.588(1/16)	37.306(1 15/32)	356	45 700	80 600
40.0(1.57)	57.150(2 1/4)	14.288(9/16)	1.588(1/16)	4.762(3/16)	3.175(1/8)	760(30)	2.381(3/32)	40.878(1 39/64)	500	61 400	116 000
40.0(1.57)	57.150(2 1/4)	14.288(9/16)	1.588(1/16)	4.762(3/16)	3.175(1/8)	760(30)	2.381(3/32)	40.878(1 39/64)	500	61 400	116 000
46.4(1.83)	63.500(2 1/2)	15.875(5/8)	1.588(1/16)	6.350(1/4)	3.175(1/8)	760(30)	2.381(3/32)	51.991(2 3/4)	892	77 600	172 000
46.4(1.83)	63.500(2 1/2)	15.875(5/8)	1.588(1/16)	6.350(1/4)	3.175(1/8)	760(30)	2.381(3/32)	51.991(2 3/4)	892	77 600	172 000
52.8(2.08)	69.850(2 3/4)	17.462(11/16)	1.588(1/16)	6.350(1/4)	3.175(1/8)	760(30)	2.381(3/32)	59.928(2 39/64)	1 450	111 000	239 000
59.4(2.34)	88.900(3 1/2)	19.050(3/4)	1.588(1/16)	6.350(1/4)	3.175(1/8)	760(30)	2.381(3/32)	64.691(2 39/64)	2 190	142 000	317 000

Ready-made Track for Cam Followers

The accuracy of the track, which an outer ring of Cam Followers contacts, greatly influences to the running performance of Cam Followers and equipments. Ready-made Track for Cam Followers is a high precision track, which was designed to achieve the original performance of Cam Followers. It can be easily installed with fixing bolts. Depending on mounting direction, two forms of A type and the B type can be selectable.

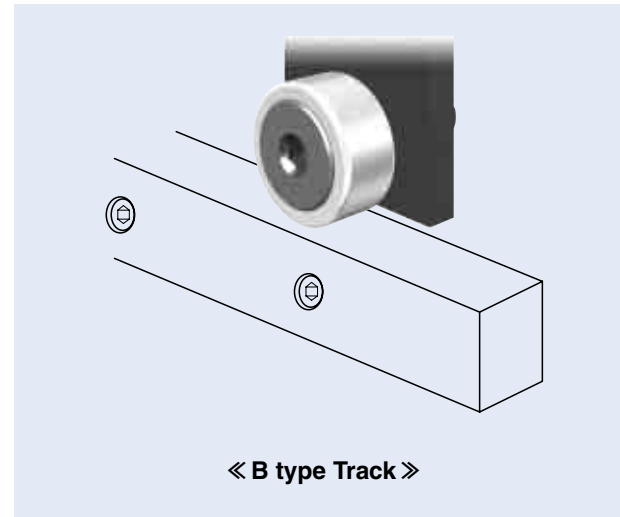
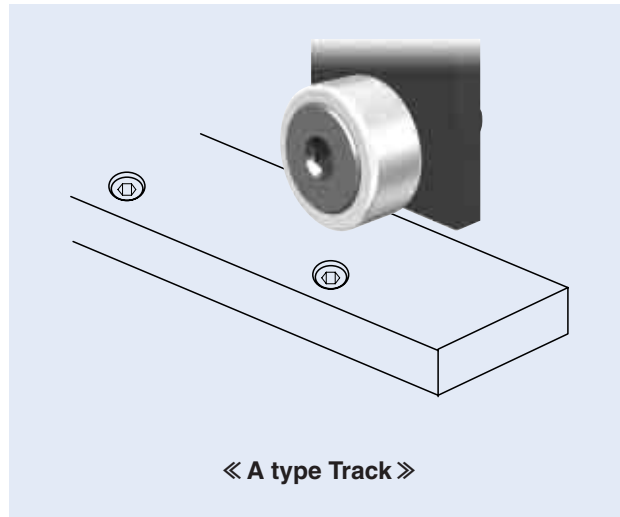

Identification Number

An example of identification number is shown below.

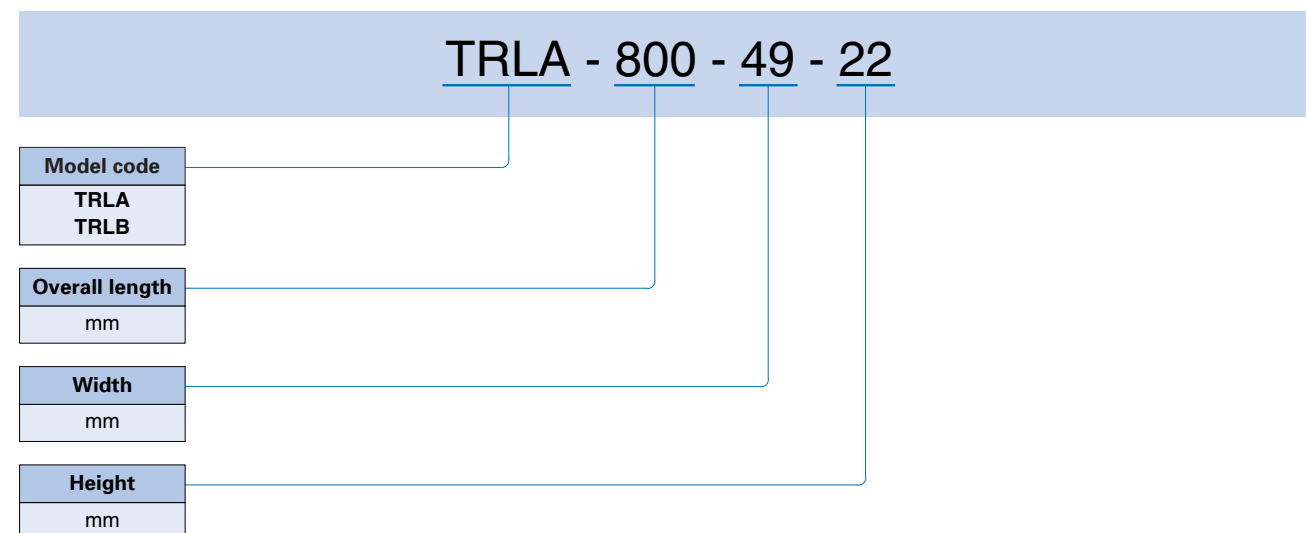

Dimensions

« A type Track »

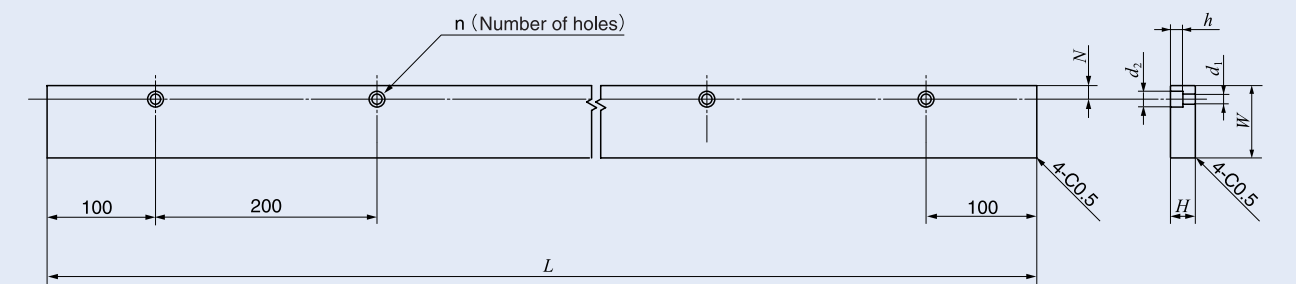

Material : SKS3 or equivalent
Surface hardness : HRC40 or more

Identification number	Nominal dimensions mm						
	$L(n)$	W	H	N	d_1	d_2	h
TRLA- 600-40-22	600(3)	40	22	12	9	14	11
TRLA- 600-49-22		49					
TRLA- 600-64-22		64					
TRLA- 800-40-22	800(4)	40					
TRLA- 800-49-22		49					
TRLA- 800-64-22		64					
TRLA-1000-40-22	1000(5)	40					
TRLA-1000-49-22		49					
TRLA-1000-64-22		64					

Remark : When a special track with different dimensions, please consult with

« B type Track »

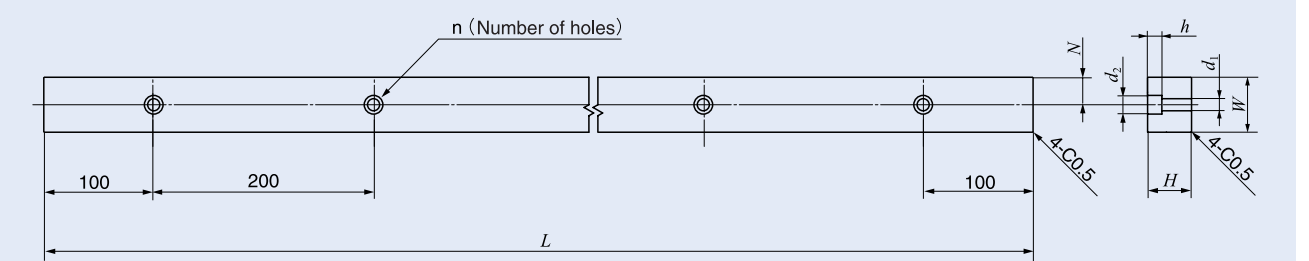

Material : SKS3 or equivalent
Surface hardness : HRC40 or more

Identification number	Nominal dimensions mm						
	$L(n)$	W	H	N	d_1	d_2	h
TRLB- 600-34-22	600(3)	34	22	17	9	14	11
TRLB- 600-50-40		50	40	25	11	17	13
TRLB- 800-34-22	800(4)	34	22	17	9	14	11
TRLB- 800-50-40		50	40	25	11	17	13
TRLB-1000-34-22	1000(5)	34	22	17	9	14	11
TRLB-1000-50-40		50	40	25	11	17	13

Remark : When a special track with different dimensions, please consult with

Application Example

Application examples of special track for Cam Followers are shown as below.
When a special track with different dimensions, please consult with **IKO**.

