

# Linear Way H

LWH...B / LWHT...B / LWHD...B / LWHS...B / LWHY

**IKO** Linear Way H incorporates two rows of large diameter steel balls in four point contact with the raceways and provides stable high accuracy and rigidity in operations even under fluctuating loads with changing direction and magnitude or complex loads. This series features the largest load ratings and rigidity among all ball types. A wide range of variations in shapes and sizes are available for selecting a model suitable for each application.

## Interchangeable

Linear Way H includes interchangeable specification products. The dimensions of slide units and track rails of this specification are individually controlled, so that the slide units and track rails can be combined, added or exchanged freely.

## Stainless steel type

The stainless steel type has excellent corrosion resistance and is most suitable for machines and equipment used in clean environments, for example, medical equipment, disk read devices and semiconductor manufacturing equipment.

## Flange type and block type

Slide units are available in five different sectional shapes: two flange types for different mounting directions and three narrow block types that are different in height and mounting directions.

## Ultra sealed specification

The track rail of this specification is ground on all surfaces, and is combined with a slide unit with specially designed end seals and under seals. Excellent dust protection performance is provided.

## Length of slide unit

A standard type slide unit and a high rigidity long type slide unit both having the same sectional dimensions are available.

## Miniature size

Miniature size models with track rail widths of 8 mm, 10 mm and 12 mm are available for use in the extended application range of Linear Way H.

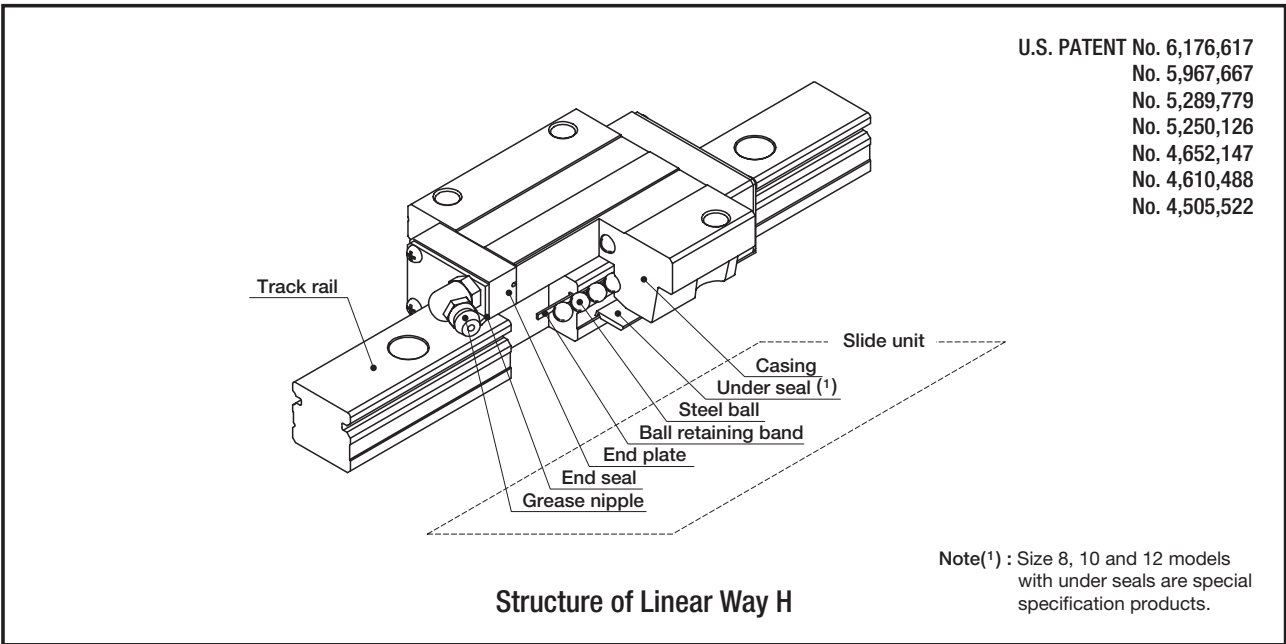

# Linear Way H series

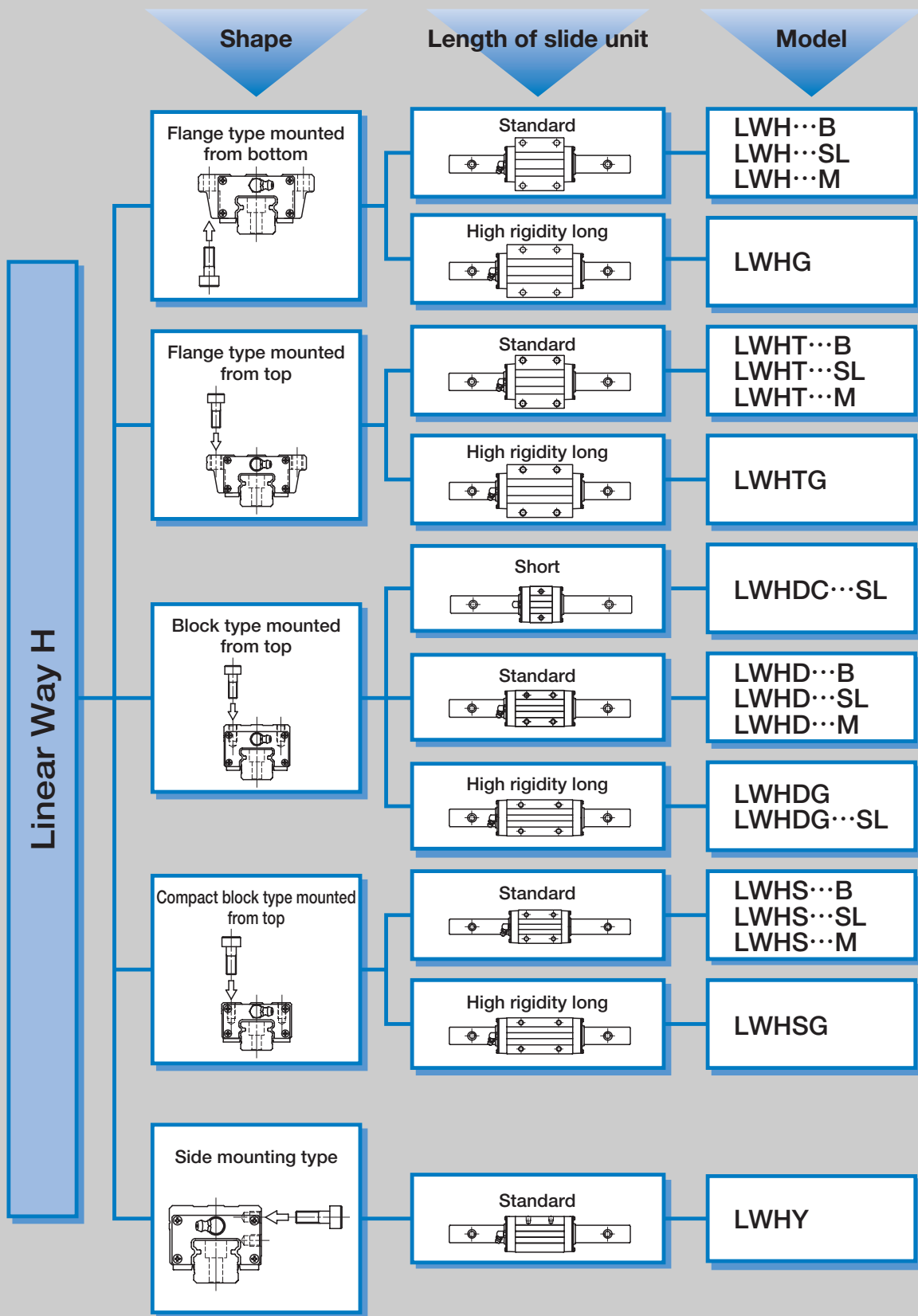

Remark 1 : Models with "SL" are stainless steel type.  
 2 : Models with "M" are ultra sealed specification products.

B

LWH, LWHT, LWHD, LWHS, LWHY

## ● Identification number and specification

The specification of Linear Way H is indicated by the identification number, consisting of a model code, a size, a part code, a seal code, a material symbol, a preload symbol, a classification symbol, an interchangeable code and any supplemental codes. For details of each specification, see page 76.

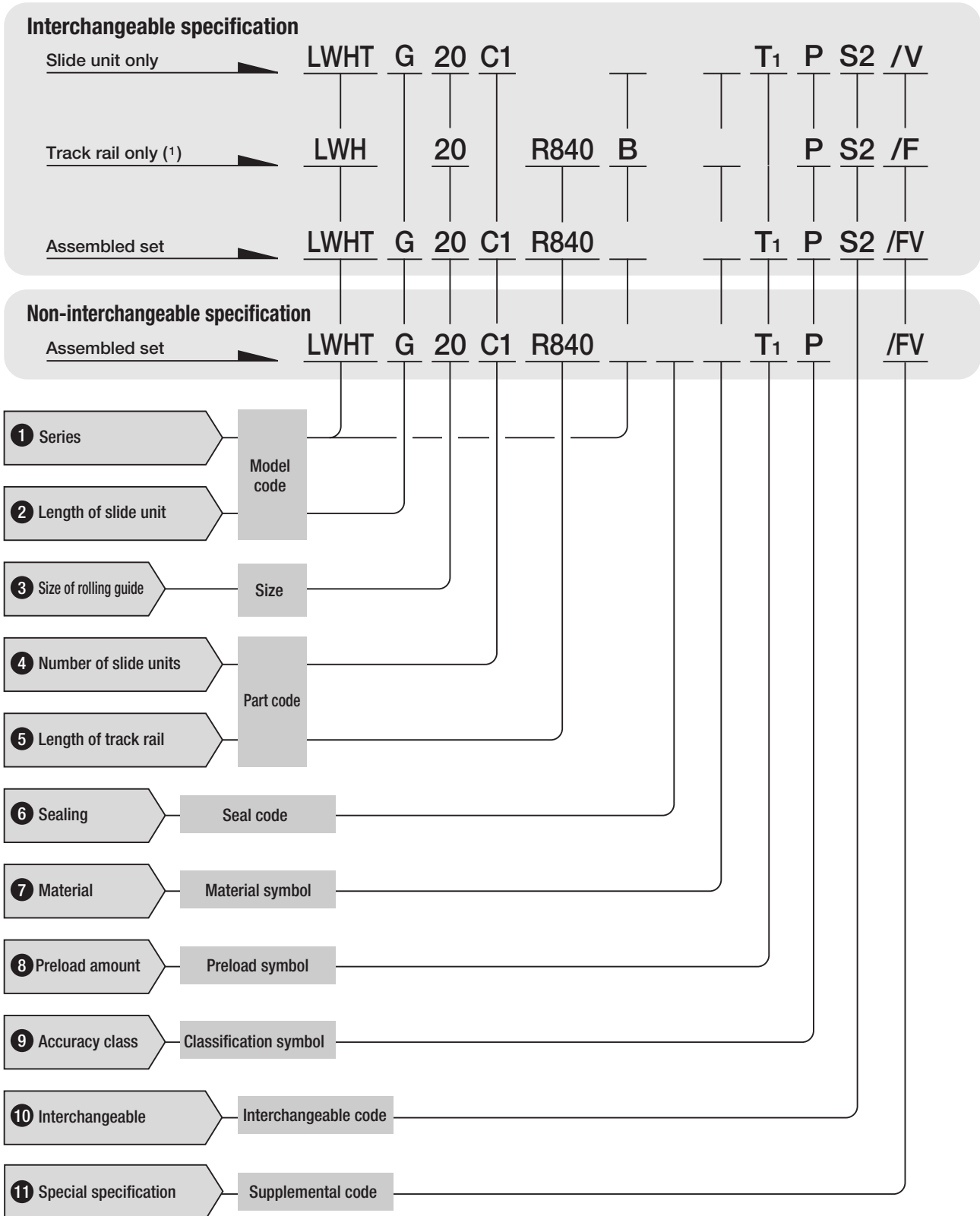

Note(1) : For the model code of a single track rail of interchangeable specification, indicate "LWH···B" (high carbon steel made) or "LWH···SL" (stainless steel made) regardless of the slide unit type to be combined.

**1 Series**

Flange type mounted from bottom : LWH ... (B)  
 Flange type mounted from top : LWHT... (B)  
 Block type mounted from top : LWHD... (B)  
 Compact block type mounted  
 from top : LWHS... (B)  
 Side mounting type : LWHY

**2 Length of slide unit**

Short : C  
 Standard : No symbol  
 High rigidity long : G

For available slide unit models, sealing, materials and sizes, see Tables 1.1 to 1.5.  
 "B" is not attached to the model codes of size 12 models, high rigidity long type models, ultra sealed specification models and stainless steel type models.

**3 Size of rolling guide**

**4 Number of slide units**

Assembled set : C○  
 Slide unit only : C1

For an assembled set, indicate the number of slide units assembled on one track rail. For a slide unit, only "C1" can be indicated.

**5 Length of track rail**

Assembled set : R○  
 Track rail only : R○

Indicate the length of track rail in mm. For standard and maximum lengths, see "Track rail length" on page B-88.

**6 Sealing**

Standard specification : No symbol  
 Ultra sealed specification : M  
 Ultra sealed track rail mounted from the lower side : MU

For applicable specifications, see Tables 1.1 to 1.5. For the specifications of ultra sealed track rail mounted from the lower side MU, the specifications of the ultra sealed specification M are applicable. For track rail dimensions, see Table 12 on page B-91.

**7 Material**

High carbon steel made : No symbol  
 Stainless steel made : SL

For applicable material types, see Tables 1.1 to 1.5.

**Table 1.1 Models and sizes of Linear Way H flange type mounted from bottom**

Size \ Model	Standard specification			Ultra sealed specification
	High carbon steel made		Stainless steel made	High carbon steel made
	Standard LWH···B	High rigidity long LWHG	Standard LWH···SL	Standard LWH···M
15	☆	—	☆	○
20	☆	☆	☆	○
25	☆	☆	☆	○
30	☆	☆	☆	○
35	☆	☆	—	○
45	☆	☆	—	○
55	☆	☆	—	—
65	☆	☆	—	—
85	—	○	—	—

Remark : The mark ☆ indicates that interchangeable specification products are available.

**Table 1.2 Models and sizes of Linear Way H flange type mounted from top**

Size \ Model	Standard specification			Ultra sealed specification
	High carbon steel made		Stainless steel made	High carbon steel made
	Standard LWHT···B	High rigidity long LWHTG	Standard LWHT···SL	Standard LWHT···M
8 (1)	—	—	☆	—
10 (1)	—	—	☆	—
12 (1)	☆ (2)	—	☆	—
15	☆	—	☆	○
20	☆	☆	☆	○
25	☆	☆	☆	○
30	☆	☆	☆	○
35	☆	☆	—	○
45	☆	☆	—	○
55	☆	☆	—	—
65	☆	☆	—	—
85	—	○	—	—

Note(1) : This model can also be mounted from the lower side.

(2) : "···B" is not attached to the model code.

Remark : The mark ☆ indicates that interchangeable specification products are available.

Table 1.3 Models and sizes of Linear Way H block type mounted from top

Size	Model	Standard specification				Ultra sealed specification	
		High carbon steel made		Stainless steel made		High carbon steel made	
		Standard LWHD...B	High rigidity long LWHDG	Short LWHDC...SL	Standard LWHD...SL	High rigidity long LWHDG...SL	Standard LWHD...M
8		—	—	☆	☆	☆	—
10		—	—	☆	☆	☆	—
12		☆ (1)	—	☆	☆	☆	—
15		☆	—	—	—	—	○
25		☆	☆	—	—	—	○
30		☆	☆	—	—	—	○
35		☆	☆	—	—	—	○
45		☆	☆	—	—	—	○
55		☆	☆	—	—	—	—
65		☆	☆	—	—	—	—

Note(1) : "...B" is not attached to the model code.  
 Remark : The mark ☆ indicates that interchangeable specification products are available.

Table 1.4 Models and sizes of Linear Way H compact block type mounted from top

Size	Model	Standard specification			Ultra sealed specification
		High carbon steel made		Stainless steel made	High carbon steel made
		Standard LWHS...B	High rigidity long LWHSG	Standard LWHS...SL	Standard LWHS...M
15		☆	—	☆	○
20		☆	☆	☆	○
25		☆	☆	☆	○
30		☆	☆	☆	○

Remark : The mark ☆ indicates that interchangeable specification products are available.

Table 1.5 Models and sizes of Linear Way H side mounting type

Size	Model	Standard specification
		High carbon steel made
		Standard LWHY
15		○
20		○
25		○
30		○
35		○
45		○
55		○
65		○

Remark : Only non-interchangeable specification products are available for this type.

## 8 Preload amount

Clearance : T<sub>0</sub>  
 Standard : No symbol  
 Light preload : T<sub>1</sub>  
 Medium preload : T<sub>2</sub>  
 Heavy preload : T<sub>3</sub>

Specify this item for an assembled set or a single slide unit. For applicable preload amount, see Table 2. For details of preload amount, see page 84.

Table 2 Applicable preload types

Size	Preload type (Symbol)				
	Clearance (T <sub>0</sub> )	Standard (No symbol)	Light preload (T <sub>1</sub> )	Medium preload (T <sub>2</sub> )	Heavy preload (T <sub>3</sub> )
8	○	☆	○	—	—
10	○	☆	○	—	—
12	○	☆	○	—	—
15	—	☆	☆	☆	☆
20	—	☆	☆	☆	☆
25	—	☆	☆	☆	☆
30	—	☆	☆	☆	☆
35	—	☆	☆	☆	☆
45	—	☆	☆	☆	☆
55	—	☆	☆	☆	☆
65	—	☆	☆	☆	☆
85	—	○	○	○	○

Remark 1 : The mark ☆ indicates that it is also applicable to interchangeable specification products.  
 2 : For the stainless steel type, medium preload (T<sub>2</sub>) and heavy preload (T<sub>3</sub>) are not applicable.

## 9 Accuracy class

High : H  
 Precision : P  
 Super precision : SP

For applicable accuracy, see Table 3. For the interchangeable specification, combine slide units and track rails of the same class. For details of accuracy, see page 79.

Table 3 Applicable accuracy class

Size	Accuracy class (Symbol)		
	High (H)	Precision (P)	Super precision (SP)
8	☆	☆	—
10	☆	☆	—
12	☆	☆	—
15	☆	☆	○
20	☆	☆	○
25	☆	☆	○
30	☆	☆	○
35	☆	☆	○
45	☆	☆	○
55	☆	☆	○
65	☆	☆	○
85	○	○	○

Remark : The mark ☆ indicates that it is also applicable to interchangeable specification products.

**10** Interchangeable code

Select group 1 : S1  
Select group 2 : S2

Specify this item for interchangeable specification products. Combine track rails and slide units with the same interchangeable code. Performance and accuracy of "S1" group and "S2" group are the same.

**11** Special specification

For applicable special specifications, see Table 4. When several special specifications are required, see Table 5. For details of special specifications, see page 86.



**Table 4 Special specifications**

Special specification	Supplemental code	Assembled set	Track rail	Slide unit	Dimension
Butt-jointing track rail	A	○ (1)	—	—	
Stainless steel end plates	BS	☆ (2)(3)	—	☆ (2)	
Opposite reference surfaces arrangement	D	☆ (3)	—	—	
Specified rail mounting hole positions	E	☆	☆	—	
Caps for rail mounting holes	F	☆ (5)	☆ (5)	—	
Inspection sheet	I	○	—	—	
Female threads for bellows	J	☆ (3)(6)	☆ (6)(7)	☆ (6)(7)	See Table 6.1, Table 6.2, Table 6.3.
Black chrome surface treatment	L	☆ (8)	☆ (6)	—	
Fluorine black chrome surface treatment	LF	☆ (6)(13)	—	—	
Supplied without track rail mounting bolt	MN	☆	☆	—	
No end seal	N	☆ (4)	—	☆	
Rail cover plate	PS	○ (4)(9)(10)	—	—	
Capillary plates	Q	☆ (3)(4)	—	☆	See Table 7.
Seals for special environment	RE	☆ (2)(4)	—	☆ (2)	
Butt-jointing interchangeable track rail	T	☆ (6)(11)	☆ (6)	—	
Under seals <sup>(12)</sup>	U	☆ (12)	—	☆ (12)	See Table 8.
Double end seals	V	☆ (6)	—	☆ (6)	See Table 9.
Matched sets to be used as an assembled group	W	○	—	—	
Specified grease	Y	☆ (13)	—	—	
Scrapers	Z	☆ (6)	—	☆ (6)	See Table 10.

Note(1) : Not applicable to size 12 of high carbon steel made models.

(2) : Applicable to size 15, 20, 25 and 30 models.

(3) : Not applicable to the side mounting type (model code: LWHY).

(4) : Not applicable to ultra sealed specification products.

(5) : Not applicable to size 8 and 10 models.

(6) : Not applicable to size 8, 10 and 12 models.

(7) : Not applicable to stainless steel made interchangeable specification products.

(8) : Only "LR" is applicable to size 8, 10 and 12 models.

(9) : Not applicable to size 12, 15 and 20 models.

(10) : Applicable to high carbon steel type.

(11) : Not applicable to non-interchangeable specification products.

(12) : Applicable to size 8, 10 and 12 models.

(13) : Not applicable to size 8, 10 and 12 models of interchangeable specification.

Remark 1 : In the table, the mark ☆ indicates that it is also applicable to interchangeable specification products.

2 : For size 85 models, no special specifications are applicable.

**Table 5** Combination of special specifications

BS	○																			
D	○	☆																		
E	-	☆	-																	
F	○	☆	☆	☆																
I	○	○	○	○	○															
J	○	☆	☆	☆	☆	○														
L	○	☆	☆	☆	☆	○	☆													
LF	○	☆	☆	☆	☆	○	☆	-												
MN	○	☆	☆	☆	☆	○	☆	☆	☆											
N	○	☆	☆	☆	-	○	-	☆	☆	☆										
PS	-	○	○	○	-	○	-	-	-	○	-									
Q	○	☆	☆	☆	☆	○	-	☆	☆	☆	☆	○								
RE	○	☆	☆	☆	☆	○	☆	☆	☆	☆	-	-	☆							
T	-	☆	☆	☆	☆	-	-	☆	☆	☆	☆	-	☆	☆						
U	○	-	☆	☆	☆	○	-	☆	-	☆	-	-	○	-	-					
V	○	☆	☆	☆	☆	○	★	☆	☆	☆	-	○	-	☆	☆	-				
W	○	○	○	-	○	○	○	○	○	○	○	○	○	-	○	○				
Y	○	☆	☆	☆	☆	○	☆	☆	☆	☆	☆	○	-	☆	☆	☆	☆	○		
Z	○	☆	☆	☆	☆	○	★	☆	☆	☆	-	-	-	☆	☆	-	★	○	☆	
	A	BS	D	E	F	I	J	L	LF	MN	N	PS	Q	RE	T	U	V	W	Y	

Remark 1 : In the table, the mark ☆ indicates that it is also applicable to interchangeable specification products.  
 2 : In the table, the mark - indicates that this combination cannot be made.  
 3 : The combinations marked ★ are applicable to non-interchangeable specification products.  
 For combinations of interchangeable specification products, consult **IICO** for further information.  
 4 : When several special specifications are required, arrange the supplemental codes alphabetically.

Table 6.1 Female threads for bellows for flange type (Supplemental code /J, /JJ)

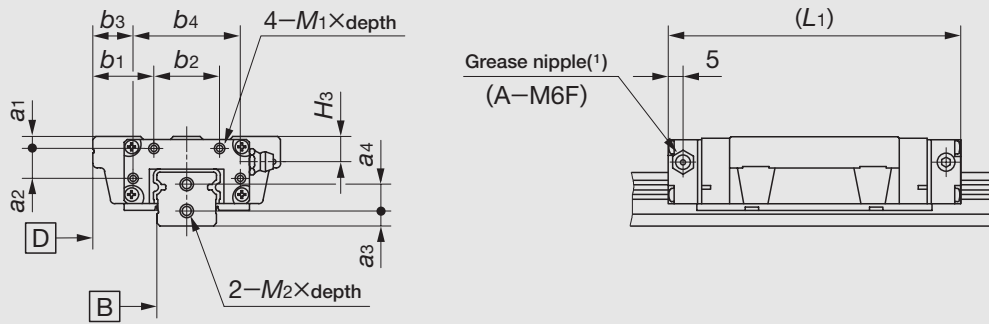

unit : mm

Model number	Slide unit							Track rail				
	a1	a2	b1	b2	b3	b4	M1×depth	L1 <sup>(2)</sup>	H3	a3	a4	M2×depth
LWH (T) 15...B	3	7	15.5	16	9.5	28	M3× 6	83	6.5	4	8	M3× 6
LWH (T) 15...SL								86				
LWH (T) 15...M								86				
LWH (T) 20...B	4	10	20.5	22	13.5	36	M3× 6	99	8.5	5	9	M4× 8
LWH (T) 20...SL								103				
LWH (T) 20...M								103				
LWH (T) G 20								128				
LWH (T) 25...B	4	13	22	26	15	40	M3× 6	110	8.5	5	12	M4× 8
LWH (T) 25...SL								115				
LWH (T) 25...M								115				
LWH (T) G 25								133				
LWH (T) 30...B	5	17	28	34	20	50	M3× 6	128	11	6	14	M4× 8
LWH (T) 30...SL								133				
LWH (T) 30...M								133				
LWH (T) G 30								154				
LWH (T) 35...B	6	20	30	40	20	60	M3× 6	137	13	7	15	M4× 8
LWH (T) 35...M								143				
LWH (T) G 35								165				
LWH (T) 45...B	7	26	35	50	23	74	M4× 8	160	15	8	19	M5×10
LWH (T) 45...M								167				
LWH (T) G 45								203				
LWH (T) 55...B	7	32	40	60	27	86	M4× 8	196	17	8	25	M5×10
LWH (T) G 55								248				
LWH (T) 65...B	10	46	50	70	32	106	M5×10	240	20	10	28	M6×12
LWH (T) G 65								314				

Note(1) : The specification and mounting position of grease nipple are different from those of the standard specification product.  
 Size 15 models are provided with a special specification grease nipple (NPB2 type). For details of dimensions, consult **IKCO** for further information.

(2) : The values are for the slide unit with female threads for bellows at both ends.

Table 6.2 Female threads for bellows for block type (Supplemental code /J, /JJ)

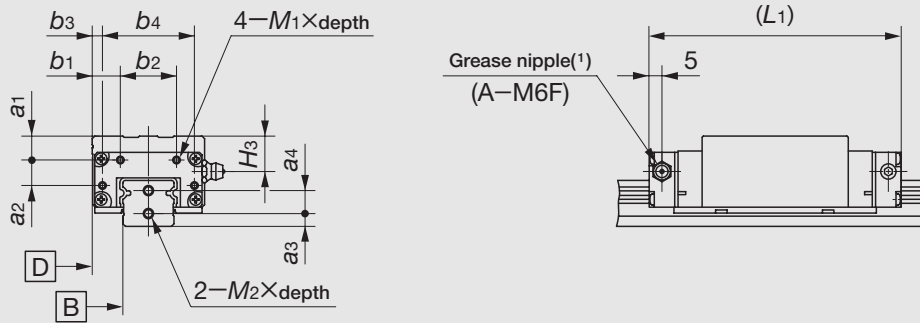

unit : mm

Model number	Slide unit									Track rail		
	a1	a2	b1	b2	b3	b4	M1×depth	L1 <sup>(2)</sup>	H3	a3	a4	M2×depth
LWHD 15···B	7	7	9	16	3	28	M3× 6	83	10.5	4	8	M3× 6
LWHD 15···M								86				
LWHD 25···B	8	13	11	26	4	40	M3× 6	110	12.5	5	12	M4× 8
LWHD 25···M								115				
LWHDG 25								133				
LWHD 30···B	8	17	13	34	5	50	M3× 6	128	14	6	14	M4× 8
LWHD 30···M								133				
LWHDG 30								154				
LWHD 35···B	13	20	15	40	5	60	M3× 6	137	20	7	15	M4× 8
LWHD 35···M								143				
LWHDG 35								165				
LWHD 45···B	17	26	18	50	6	74	M4× 8	160	25	8	19	M5×10
LWHD 45···M								167				
LWHDG 45								203				
LWHD 55···B	17	32	20	60	7	86	M4× 8	196	27	8	25	M5×10
LWHDG 55								248				
LWHD 65···B	10	46	28	70	10	106	M5×10	240	20	10	28	M6×12
LWHDG 65								314				

Note<sup>(1)</sup> : The specification and mounting position of grease nipple are different from those of the standard specification product.  
 Size 15 models are provided with a special specification grease nipple (NPB2 type). For details of dimensions, consult **IKO** for further information.

<sup>(2)</sup> : The values are for the slide unit with female threads for bellows at both ends.

Table 6.3 Female threads for bellows for compact block type (Supplemental code /J, /JJ)

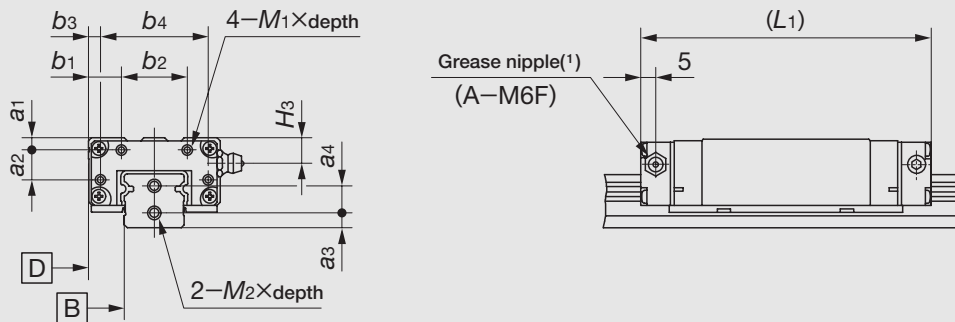

unit : mm

Model number	Slide unit									Track rail		
	a1	a2	b1	b2	b3	b4	M1×depth	L1 <sup>(2)</sup>	H3	a3	a4	M2×depth
LWHS 15...B	3	7	9	16	3	28	M3×6	83	6.5	4	8	M3×6
LWHS 15...SL												
LWHS 15...M												
LWHS 20...B	4	10	11	22	4	36	M3×6	99	8.5	5	9	M4×8
LWHS 20...SL								103				
LWHS 20...M								128				
LWHS 20...M								128				
LWHS 25...B	4	13	11	26	4	40	M3×6	110	8.5	5	12	M4×8
LWHS 25...SL								115				
LWHS 25...M								133				
LWHS 25...M								133				
LWHS 30...B	5	17	13	34	5	50	M3×6	128	11	6	14	M4×8
LWHS 30...SL								133				
LWHS 30...M								133				
LWHS 30...M								154				

Note<sup>(1)</sup> : The specification and mounting position of grease nipple are different from those of the standard specification product.  
 Size 15 models are provided with a special specification grease nipple (NPB2 type). For details of dimensions, consult **IKO** for further information.

<sup>(2)</sup> : The values are for the slide unit with female threads for bellows at both ends.

Table 7 Slide unit with capillary plates (Supplemental code /Q)

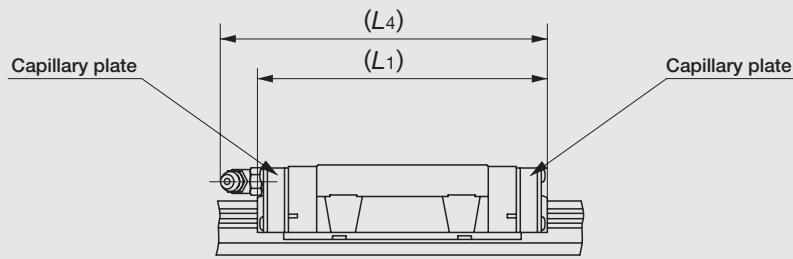

unit : mm

Model number	L1	L4
LWHDC 8...SL	26	—
LWHD 8...SL	32	—
LWHDG 8...SL	39	—
LWHDC 10...SL	34	—
LWHD 10...SL	42	—
LWHDG 10...SL	50	—
LWHDC 12...SL	44	48
LWHD 12	56	60
LWHD 12...SL		
LWHDG 12...SL	68	72
LWH 15...B	75	78
LWH 15...SL		
LWH 20...B	92	105
LWH 20...SL		
LWHG 20	121	134

Model number	L1	L4
LWH 25...B	105	117
LWH 25...SL		
LWHG 25	127	139
LWH 30...B	125	135
LWH 30...SL		
LWHG 30	151	161
LWH 35...B	134	146
LWHG 35	162	174
LWH 45...B	160	170
LWHG 45	203	213
LWH 55...B	196	207
LWHG 55	248	258
LWH 65...B	246	253
LWHG 65	320	327

Remark : The above table shows representative model numbers but is applicable to all models of the same size.

Table 8 H<sub>1</sub> dimension of slide unit with under seals (Supplemental code /U)

unit : mm

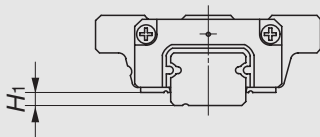

Model number	H <sub>1</sub>
LWH 8...SL	1.5
LWH 10...SL	1.8
LWH 12	3.2

Remark 1 : The above table shows representative model numbers but is applicable to all models of the same size.

2 : H<sub>1</sub> dimension of size 12 models is the same as the dimension without under seals.

Table 9 Slide unit with double end seals (Supplemental code /V, /VV)

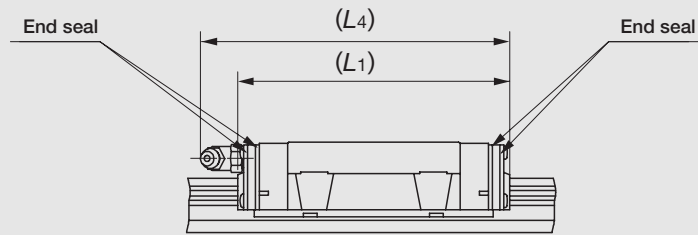

unit : mm

Model number	$L_1$	$L_4$
LWH 15···B	72	77
LWH 15···SL		
LWH 15···M	71	76
LWH 20···B	91	104
LWH 20···SL		
LWH 20···M	90	103
LWHG 20	119	133
LWH 25···B	104	116
LWH 25···SL		
LWH 25···M	103	115
LWHG 25	127	139
LWH 30···B	122	134
LWH 30···SL		
LWH 30···M	121	133
LWHG 30	148	160

Model number	$L_1$	$L_4$
LWH 35···B	133	146
LWH 35···M		
LWHG 35	161	173
LWH 45···B	159	170
LWH 45···M	158	
LWHG 45	202	213
LWH 55···B	196	206
LWHG 55	247	258
LWH 65···B	241	251
LWHG 65	316	326

Remark 1 : The above table shows representative model numbers but is applicable to all models of the same size.  
 2 : The values are for the slide unit with double end seals at both ends.

Table 10 Slide unit with scrapers (Supplemental code /Z, /ZZ)

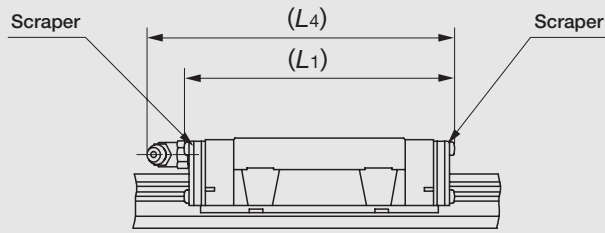

unit : mm

Model number	L <sub>1</sub>	L <sub>4</sub>
LWH 15...B	73	75
LWH 15...SL		
LWH 15...M	72	74
LWH 20...B	91	104
LWH 20...SL		
LWH 20...M	90	101
LWHG 20	119	133
LWH 25...B	104	116
LWH 25...SL		
LWH 25...M	103	113
LWHG 25	126	139

Model number	L <sub>1</sub>	L <sub>4</sub>
LWH 30...B	124	135
LWH 30...SL		
LWH 30...M	123	131
LWHG 30	150	161
LWH 35...B	133	146
LWH 35...M		
LWHG 35	161	174
LWH 45...B	160	171
LWH 45...M	159	170
LWHG 45	203	214
LWH 55...B	196	207
LWHG 55	248	258
LWH 65...B	242	252
LWHG 65	317	326

Remark 1 : The above table shows representative model numbers but is applicable to all models of the same size.

2 : The values are for the slide unit with scrapers at both ends.



## Track rail length

Standard and maximum lengths of track rails are shown in Tables 11.1, 11.2 and 11.3. Track rails of any length are also available. Simply indicate the required length of track rail in mm in the identification number. For the tolerances of  $E$  dimension and track rail length, consult **IKO** for further information.

- For track rails of non-interchangeable specification longer than the maximum length shown in Tables 11.1, 11.2 and 11.3, butt-jointing track rails are available upon request. In this case, indicate "/A" in the identification number.
- $E$  dimensions at both ends are the same and are within the standard range of  $E$  unless otherwise specified. To change these dimensions, specify the specified rail mounting hole positions "/E" of special specification. For details, see page 89.

Table 11.1 Standard and maximum lengths of high carbon steel track rails

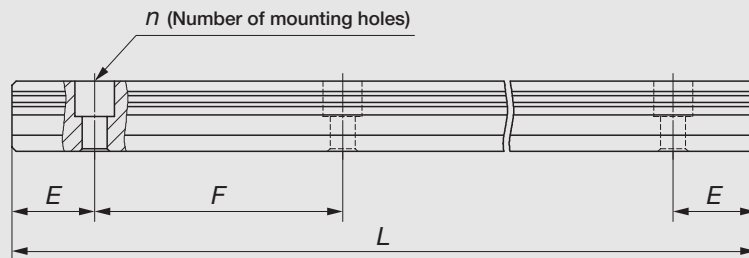

unit : mm

Item	Model number	LWH 12	LWH 15...B	LWH 20...B	LWH 25...B	LWH 30...B
Standard length $L(n)$		80( 2)	180( 3)	240( 4)	240( 4)	480( 6)
		160( 4)	240( 4)	480( 8)	480( 8)	640( 8)
		240( 6)	360( 6)	660(11)	660(11)	800(10)
		320( 8)	480( 8)	840(14)	840(14)	1 040(13)
		400(10)	660(11)	1 020(17)	1 020(17)	1 200(15)
		480(12)	900(15)	1 200(20)	1 200(20)	1 520(19)
		560(14)	1 200(20)	1 500(25)	1 500(25)	2 000(25)
		640(16)			1 980(33)	
	720(18)					
Pitch of mounting holes $F$		40	60	60	60	80
$E$		20	30	30	30	40
Standard range of $E^{(1)}$	incl.	5.5	7	8	9	10
	under	25.5	37	38	39	50
Maximum length <sup>(2)</sup>		1 480	1 500 (3 000)	1 980 (3 000)	3 000 (3 960)	2 960 (4 000)
Item	Model number	LWH 35...B	LWH 45...B	LWH 55...B	LWH 65...B	
Standard length $L(n)$		480( 6)	840( 8)	840( 7)	1 500(10)	
		640( 8)	1 050(10)	1 200(10)	1 950(13)	
		800(10)	1 260(12)	1 560(13)	3 000(20)	
		1 040(13)	1 470(14)	1 920(16)		
		1 200(15)	1 995(19)	3 000(25)		
		1 520(19)				
Pitch of mounting holes $F$		80	105	120	150	
$E$		40	52.5	60	75	
Standard range of $E^{(1)}$	incl.	10	12.5	15	17	
	under	50	65	75	92	
Maximum length <sup>(2)</sup>		2 960 (4 000)	2 940 (3 990)	3 000 (3 960)	3 000 (3 900)	

Note<sup>(1)</sup> : Not applicable to the track rail with female threads for bellows (supplemental code "/J").

<sup>(2)</sup> : Track rails with the maximum lengths in parentheses can be manufactured. Consult **IKO** for further information.

Remark : The above table shows representative model numbers but is applicable to all models of the same size. For the ultra sealed specification, see Table 11.3 on page B-90.

Table 11.2 Standard and maximum lengths of stainless steel track rails

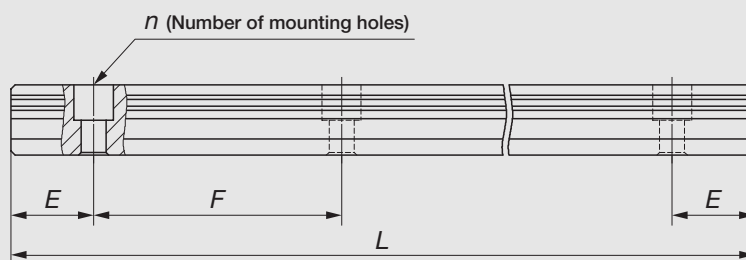

unit : mm

Item	Model number	LWH 8...SL	LWH 10...SL	LWH 12...SL	LWH 15...SL
Standard length $L(n)$		40( 2)	50( 2)	80( 2)	180( 3)
		80( 4)	100( 4)	160( 4)	240( 4)
		120( 6)	150( 6)	240( 6)	360( 6)
		160( 8)	200( 8)	320( 8)	480( 8)
		200(10)	250(10)	400(10)	660(11)
		240(12)	300(12)	480(12)	
		280(14)	350(14)	560(14)	
Pitch of mounting holes $F$		20	25	40	60
$E$		10	12.5	20	30
Standard range of $E^{(1)}$	incl.	4.5	5	5.5	7
	under	14.5	17.5	25.5	37
Maximum length <sup>(2)</sup>		480 (1 000)	850 (1 000)	1 000 (1 480)	1 200 (1 500)
Item	Model number	LWH 20...SL	LWH 25...SL	LWH 30...SL	
Standard length $L(n)$		240( 4)	240( 4)	480( 6)	
		480( 8)	480( 8)	640( 8)	
		660(11)	660(11)	800(10)	
		840(14)	840(14)	1 040(13)	
Pitch of mounting holes $F$		60	60	80	
$E$		30	30	40	
Standard range of $E^{(1)}$	incl.	8	9	10	
	under	38	39	50	
Maximum length <sup>(2)</sup>		1 200 (1 980)	1 200 (1 980)	1 200 (2 000)	

Note<sup>(1)</sup> : Not applicable to the track rail with female threads for bellows (supplemental code "/J").

(<sup>2</sup>) : Track rails with the maximum lengths shown in parentheses can also be manufactured. Consult **IKO** for further information.

Remark : The above table shows representative model numbers but is applicable to all models of the same size.

Table 11.3 Standard and maximum lengths of ultra sealed type high carbon steel track rails

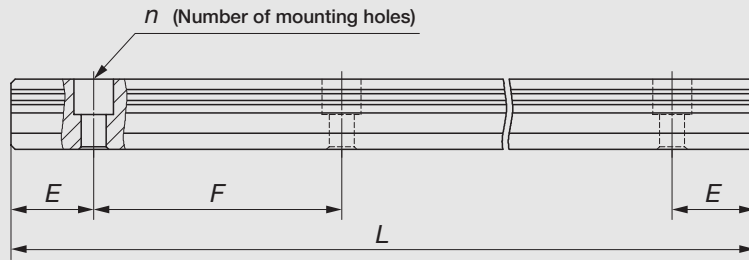

unit : mm

Item	Model number	LWH 15...M	LWH 20...M	LWH 25...M	LWH 30...M	LWH 35...M	LWH 45...M
Standard length $L(n)$		180( 3)	240( 4)	240( 4)	480( 6)	480( 6)	840( 8)
		240( 4)	480( 8)	480( 8)	640( 8)	640( 8)	1 050(10)
		360( 6)	660(11)	660(11)	800(10)	800(10)	1 260(12)
		480( 8)	840(14)	840(14)	1 040(13)	1 040(13)	1 470(14)
		660(11)	1 020(17)	1 020(17)	1 200(15)	1 200(15)	1 995(19)
			1 200(20)	1 200(20)	1 520(19)	1 520(19)	
Pitch of mounting holes $F$		60	60	60	80	80	105
$E$		30	30	30	40	40	52.5
Standard range of $E^{(1)}$	incl.	7	8	9	10	10	12.5
	under	37	38	39	50	50	65
Maximum length		1 500	1 980	3 000	2 960	2 960	2 940
Maximum number of butt-jointing rails		3	3	3	3	3	3
Maximum length of butt-jointing rails		4 200	5 640	8 700	8 480	8 480	8 295

Note(1) : Not applicable to the track rail with female threads for bellows (supplemental code "/J").

Remark : The above table shows representative model numbers but is applicable to all models of the same size.

## ● Specification of ultra sealed type track rail mounted from the lower side

In this specification, aluminum caps are press-fitted into the track rail mounting holes in advance and the track rail is fixed from the mounting surface side. As the top surface of the track rail is flat, close contact with seals can be obtained, further improving the sealing effect.

Table12 Dimensions of ultra sealed type track rails mounted from the lower side

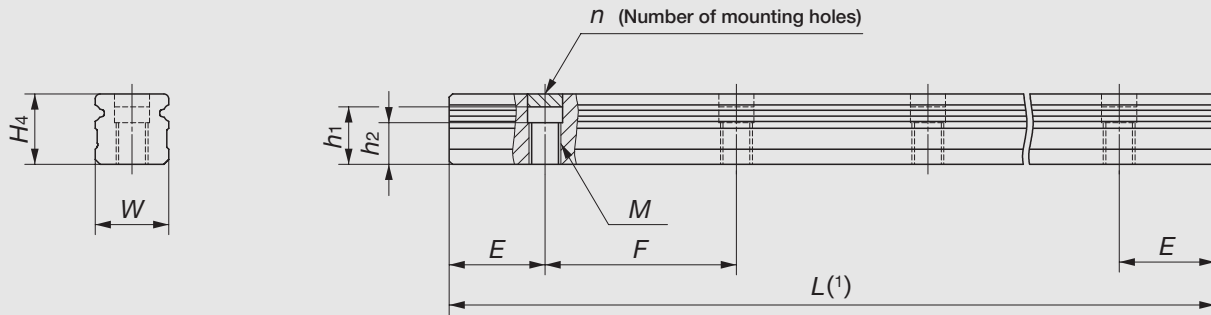

Model number	Mass (Ref.) kg/m	Dimensions mm						
		$W$	$H_4$	$E$	$F$	$M$	$h_1^{(2)}$	$h_2$
LWH 15...MU	1.47	15	15	30	60	M 6	12	9
LWHT 15...MU								
LWHD 15...MU								
LWHS 15...MU								
LWH 20...MU	2.56	20	18	30	60	M 8	13.5	9.5
LWHT 20...MU								
LWHS 20...MU								
LWH 25...MU	3.50	23	22	30	60	M10	18	13
LWHT 25...MU								
LWHD 25...MU								
LWHS 25...MU								
LWH 30...MU	4.82	28	25	40	80	M12	20	13
LWHT 30...MU								
LWHD 30...MU								
LWHS 30...MU								
LWH 35...MU	6.85	34	28	40	80	M12	23	16
LWHT 35...MU								
LWHD 35...MU								
LWH 45...MU	10.7	45	34	52.5	105	M16	29	17
LWHT 45...MU								
LWHD 45...MU								

Note<sup>(1)</sup> : For the track rail length, see Table 11.3 on page B-90.

<sup>(2)</sup> : The mounting bolt length should be less than the  $h_1$  dimension.

Remark : The track rail mounting bolts are not appended.

Flange type mounted from bottom  
**LWH ...B**  
**LWHG**  
**LWH ...SL**(Stainless steel made)  
**LWH ...M**(Ultra sealed type)

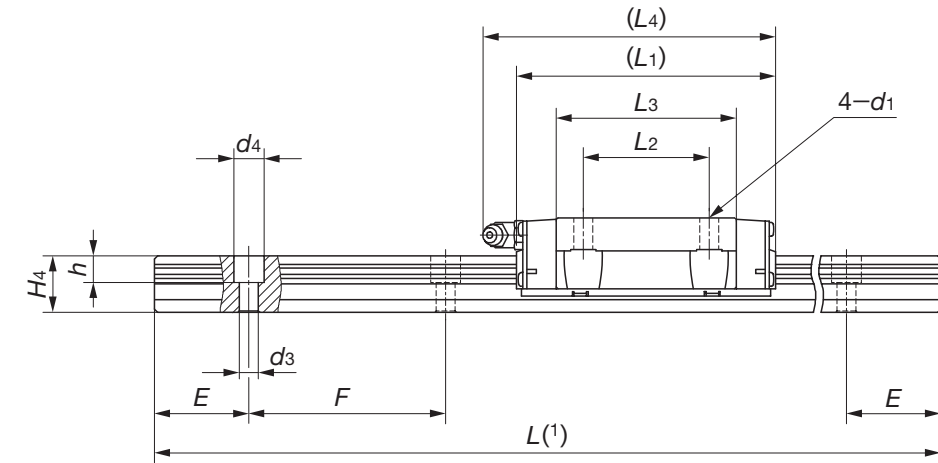
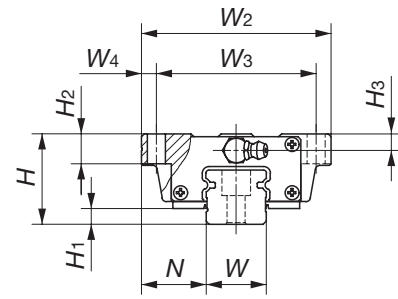

Model number	Interchangeable	Mass (Ref.)		Dimensions of assembly mm			Dimensions of slide unit mm							
		Slide unit kg	Track rail kg/m	H	H <sub>1</sub>	N	W <sub>2</sub>	W <sub>3</sub>	W <sub>4</sub>	L <sub>1</sub>	L <sub>2</sub>	L <sub>3</sub>	L <sub>4</sub>	d <sub>1</sub>
LWH 15...B	☆	0.22	1.47	24	4.5	16	47	38	4.5	66	30	44.6	69	4.5
LWH 15...SL	☆													
LWH 15...M														
LWH 20...B	☆	0.48	2.56	30	5	21.5	63	53	5	83	40	57.2	95	6
LWH 20...SL	☆													
LWH 20...M														
LWHG 20	☆	0.71								112		86	124	
LWH 25...B	☆	0.70	3.50	36	6.5	23.5	70	57	6.5	95	45	64.7	106	7
LWH 25...SL	☆													
LWH 25...M														
LWHG 25	☆	0.93								118		87.4	129	

		Dimensions of track rail mm								Mounting bolt for track rail mm Bolt size x length	Basic dynamic load rating <sup>(2)</sup> C N	Basic static load rating <sup>(2)</sup> C <sub>0</sub> N	Static moment rating <sup>(2)</sup>		
H <sub>2</sub>	H <sub>3</sub>	W	H <sub>4</sub>	d <sub>3</sub>	d <sub>4</sub>	h	E	F	T <sub>0</sub> N·m				T <sub>x</sub> N·m	T <sub>y</sub> N·m	
7	4.5	15	15	4.5	8	6	30	60	M4×16	11 600	13 400	112	95.6 556	95.6 556	
10	5.5	20	18	6	9.5	8.5	30	60	M5×18	18 100	21 100	232	195 1 090	195 1 090	
										24 100	31 700	349	421 2 140	421 2 140	
10	6.5	23	22	7	11	9	30	60	M6×22	25 200	28 800	362	309 1 690	309 1 690	
										30 800	38 300	483	533 2 740	533 2 740	

Note<sup>(1)</sup>: Track rail lengths are shown in Table 11.1 on page B-88, Table 11.2 on page B-89 and Table 11.3 on page B-90.  
<sup>(2)</sup>: The directions of basic dynamic load rating (C), basic static load rating (C<sub>0</sub>) and static moment rating (T<sub>0</sub>, T<sub>x</sub>, T<sub>y</sub>) are shown in the sketches below. The upper values in the T<sub>x</sub> and T<sub>y</sub> columns apply to one slide unit, and the lower values apply to two slide units in close contact.  
 Remark 1: The mark ☆ indicates that interchangeable specification products are available.  
 2: The appended track rail mounting bolts are hexagon socket head bolts of JIS B 1176 or equivalent.  
 For stainless steel type Linear Way H, stainless steel bolts are appended.  
 3: For grease nipple specifications, see page 97.

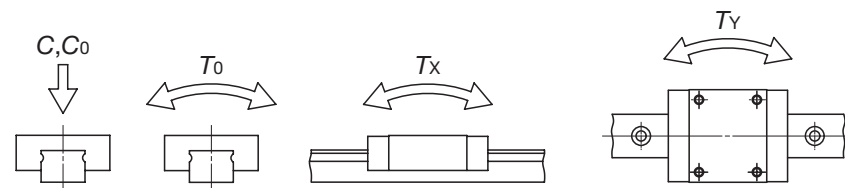

Example of identification number of assembled set (For details, see "Identification number and specification".)

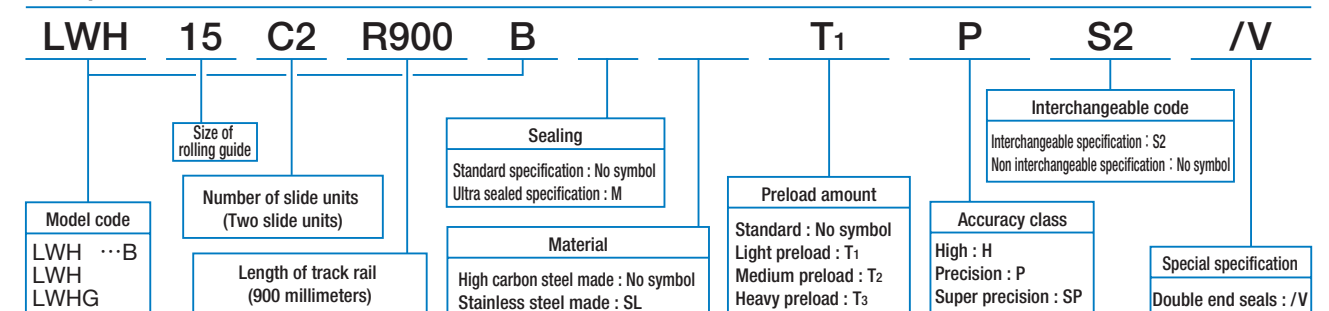

Flange type mounted from bottom  
**LWH ...B**  
**LWHG**  
**LWH ...SL**(Stainless steel made)  
**LWH ...M**(Ultra sealed type)

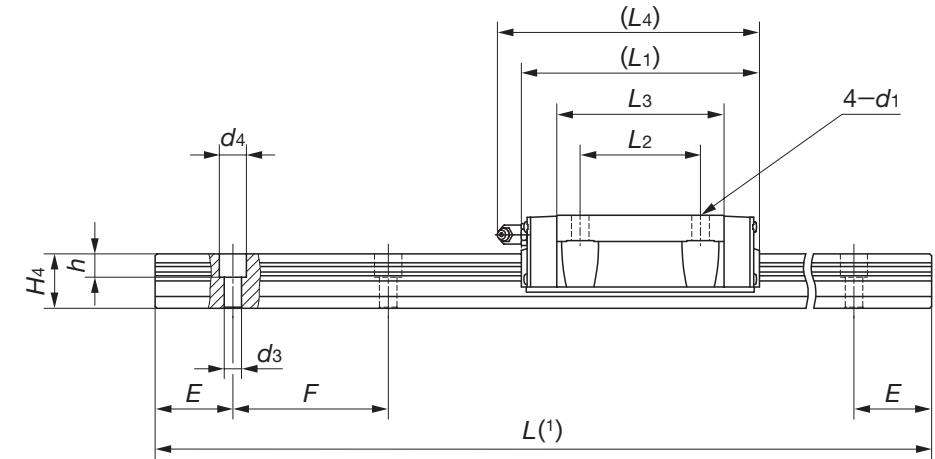
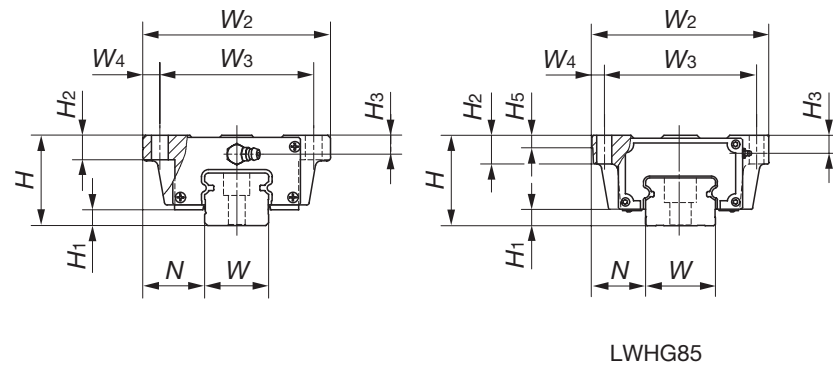

Model number	Interchangeable	Mass (Ref.)		Dimensions of assembly mm			Dimensions of slide unit mm																			
		Slide unit kg	Track rail kg/m	H	H <sub>1</sub>	N	W <sub>2</sub>	W <sub>3</sub>	W <sub>4</sub>	L <sub>1</sub>	L <sub>2</sub>	L <sub>3</sub>	L <sub>4</sub>	d <sub>1</sub>												
LWH 30...B	☆	1.28	4.82	42	7	31	90	72	9	113	52	80.6	124	9												
LWH 30...SL	☆																									
LWH 30...M																										
LWHG 30	☆	1.69								139		106.6	150													
LWH 35...B	☆	1.79	6.85	48	8	33	100	82	9	123	62	86.2	135	9												
LWH 35...M																										
LWHG 35	☆														2.35								151		114	163
LWH 45...B	☆	3.17	10.7	60	10	37.5	120	100	10	147	80	103.4	158	11												
LWH 45...M																										
LWHG 45	☆														4.34								190		146.6	201
LWH 55...B	☆	5.30	15.5	70	13	43.5	140	116	12	183	95	132	194	14												
LWHG 55	☆														7.40								235		183.6	246
LWH 65...B	☆														12.3	22.2	90	14	53.5	170	142	14	229	110	164	239
LWHG 65	☆	17.6								303		238.8	313													
LWHG 85		25.9	34.6	110	16	65	215	185	15	318	140	240	—	18												

Note(1) : Track rail lengths are shown in Table 11.1 on page B-88, Table 11.2 on page B-89 and Table 11.3 on page B-90.  
 (2) : The directions of basic dynamic load rating (C), basic static load rating (C<sub>0</sub>) and static moment rating (T<sub>0</sub>, T<sub>x</sub>, T<sub>y</sub>) are shown in the sketches below. The upper values in the T<sub>x</sub> and T<sub>y</sub> columns apply to one slide unit, and the lower values apply to two slide units in close contact.

Remark 1 : The mark ☆ indicates that interchangeable specification products are available.  
 2 : The appended track rail mounting bolts are hexagon socket head bolts of JIS B 1176 or equivalent. For stainless steel type Linear Way H, stainless steel bolts are appended.  
 3 : For grease nipple specifications, see page 97.

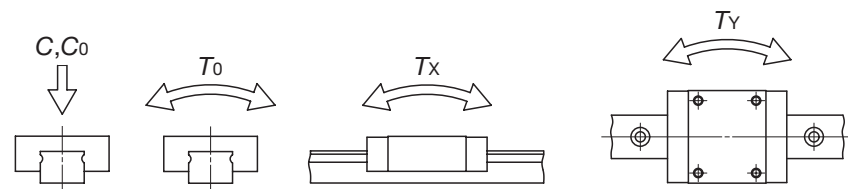

			Dimensions of track rail mm							Mounting bolt for track rail mm	Basic dynamic load rating <sup>(2)</sup>	Basic static load rating <sup>(2)</sup>	Static moment rating <sup>(2)</sup>		
H <sub>2</sub>	H <sub>3</sub>	H <sub>5</sub>	W	H <sub>4</sub>	d <sub>3</sub>	d <sub>4</sub>	h	E	F	Bolt size x length	C N	C <sub>0</sub> N	T <sub>0</sub> N·m	T <sub>x</sub> N·m	T <sub>y</sub> N·m
10	8	—	28	25	9	14	12	40	80	M 8×28	35 400	40 700	623	536	536
											42 700	53 200	814	894	894
13	10	—	34	28	9	14	12	40	80	M 8×28	48 700	53 700	823	631	579
											59 500	71 600	1 100	1 090	1 000
15	13	—	45	34	14	20	17	52.5	105	M12×35	74 600	80 200	1 610	1 150	1 160
											95 200	114 000	2 280	2 240	2 050
17	14	—	53	41	16	23	20	60	120	M14×45	113 000	121 000	2 870	2 210	2 030
											142 000	168 000	3 970	4 120	3 780
23	20	—	63	48	18	26	22	75	150	M16×50	176 000	184 000	5 180	4 130	3 790
											229 000	269 000	7 560	22 000	20 200
30	22	15	85	58	26	39	30	90	180	M24×60	374 000	384 000	11 900	8 530	7 810
														41 500	38 100

Example of identification number of assembled set (For details, see "Identification number and specification".)

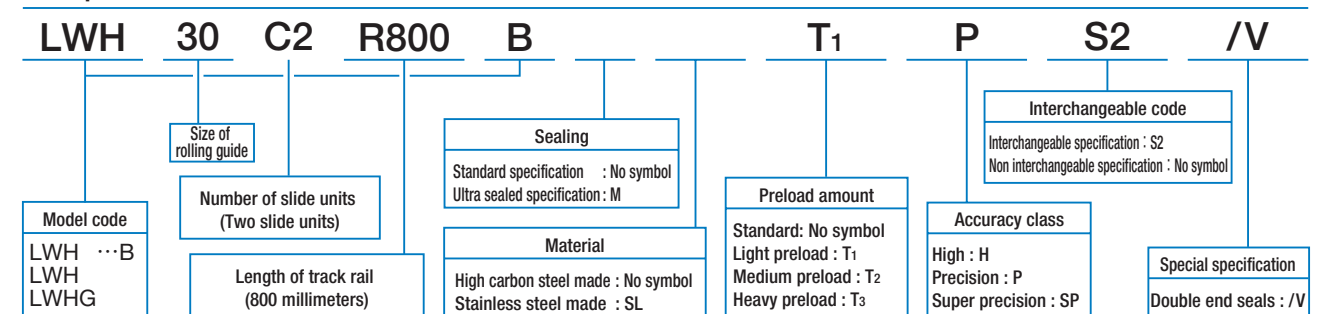

Flange type mounted from top  
**LWHT ...B**  
**LWHTG**  
**LWHT ...SL**(Stainless steel made)  
**LWHT ...M**(Ultra sealed type)

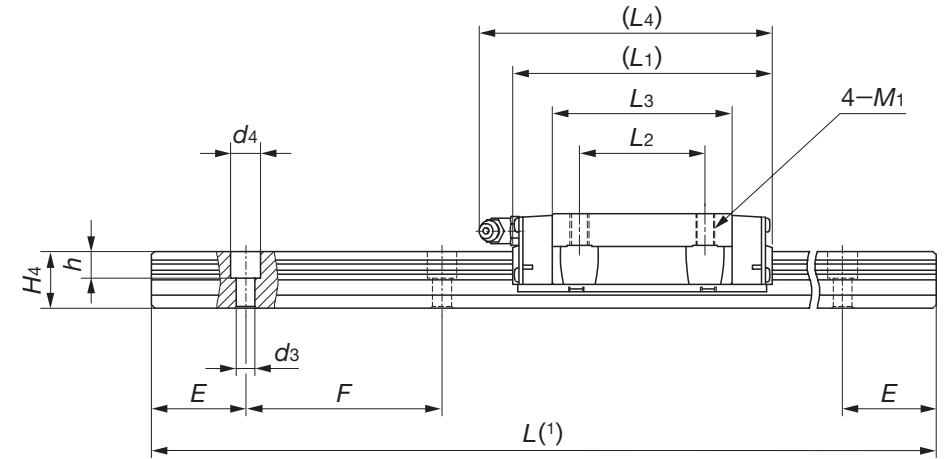
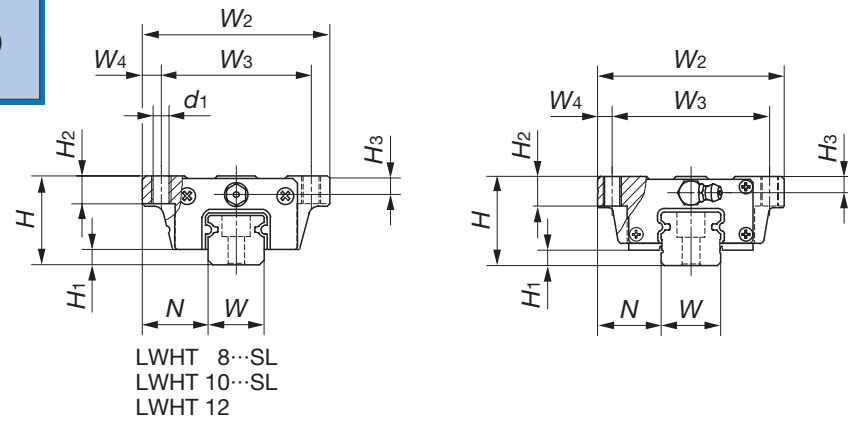

Model number	Interchangeable	Mass (Ref.)		Dimensions of assembly mm			Dimensions of slide unit mm							
		Slide unit kg	Track rail kg/m	H	H <sub>1</sub>	N	W <sub>2</sub>	W <sub>3</sub>	W <sub>4</sub>	L <sub>1</sub>	L <sub>2</sub>	L <sub>3</sub>	L <sub>4</sub>	d <sub>1</sub> <sup>(3)</sup>
LWHT 8...SL	☆	0.015	0.32	10	2.1	8	24	19	2.5	24	10	15.3	—	1.9
LWHT 10...SL	☆	0.032	0.47	12	2.4	10	30	24	3	32	12	21.4	—	2.6
LWHT 12	☆	0.11	0.86	19	3.2	14	40	32	4	46	15	31.6	50	3.4
LWHT 12...SL	☆													
LWHT 15...B	☆	0.22	1.47	24	4.5	16	47	38	4.5	66	30	44.6	69	—
LWHT 15...SL	☆													
LWHT 15...M														
LWHT 20...B	☆	0.48	2.56	30	5	21.5	63	53	5	83	40	57.2	95	—
LWHT 20...SL	☆													
LWHT 20...M														
LWHTG 20	☆	0.71								112		86	124	
LWHT 25...B	☆	0.70	3.50	36	6.5	23.5	70	57	6.5	95	45	64.7	106	—
LWHT 25...SL	☆													
LWHT 25...M														
LWHTG 25	☆	0.93								118		87.4	129	

Note(1) : Track rail lengths are shown in Table 11.1 on page B-88, Table 11.2 on page B-89 and Table 11.3 on page B-90.  
 (2) : The directions of basic dynamic load rating (C), basic static load rating (C<sub>0</sub>) and static moment rating (T<sub>0</sub>, T<sub>x</sub>, T<sub>y</sub>) are shown in the sketches below. The upper values in the T<sub>x</sub> and T<sub>y</sub> columns apply to one slide unit, and the lower values apply to two slide units in close contact.  
 (3) : LWHT8...SL, LWHT10...SL and LWHT12...SL can also be mounted from the lower side.  
 Remark 1 : The mark ☆ indicates that interchangeable specification products are available.  
 2 : The appended track rail mounting bolts are hexagon socket head bolts of JIS B 1176 or equivalent.  
 For stainless steel type Linear Way H, stainless steel bolts are appended.  
 3 : For grease nipple and oil hole specifications, see page 97.  
 4 : LWHT8...SL and LWHT10...SL are provided with an oil hole.

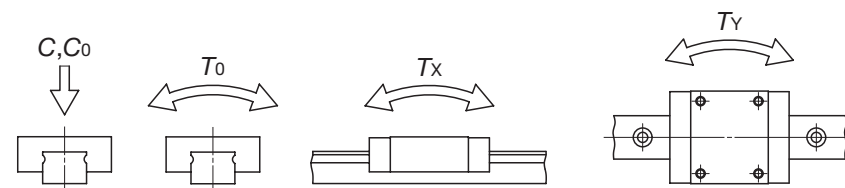

M <sub>1</sub>	H <sub>2</sub>	H <sub>3</sub>	Dimensions of track rail mm							Mounting bolt for track rail mm Bolt size x length	Basic dynamic load rating <sup>(2)</sup> C N	Basic static load rating <sup>(2)</sup> C <sub>0</sub> N	Static moment rating <sup>(2)</sup>		
			W	H <sub>4</sub>	d <sub>3</sub>	d <sub>4</sub>	h	E	F				T <sub>0</sub> N·m	T <sub>x</sub> N·m	T <sub>y</sub> N·m
M2.3	3.5	2	8	6	2.4	4.2	2.3	10	20	M2×8	1 510	2 120	8.8	5.5 32.0	4.7 26.9
M3	4.5	2.5	10	7	3.5	6	3.5	12.5	25	M3×8	2 640	3 700	19.2	13.3 73.8	11.1 61.9
M4	6	4	12	10.5	3.5	6	4.5	20	40	M3×12	6 260	8 330	51.6	44.7 237	37.5 199
M5	7	4.5	15	15	4.5	8	6	30	60	M4×16	11 600	13 400	112	95.6 556	95.6 556
M6	10	5.5	20	18	6	9.5	8.5	30	60	M5×18	18 100	21 100	232	195 1 090	195 1 090
M8	10	6.5	23	22	7	11	9	30	60	M6×22	25 200	28 800	362	309 1 690	309 1 690
											30 800	38 300	483	533 2 740	533 2 740

Example of identification number of assembled set (For details, see "Identification number and specification".)

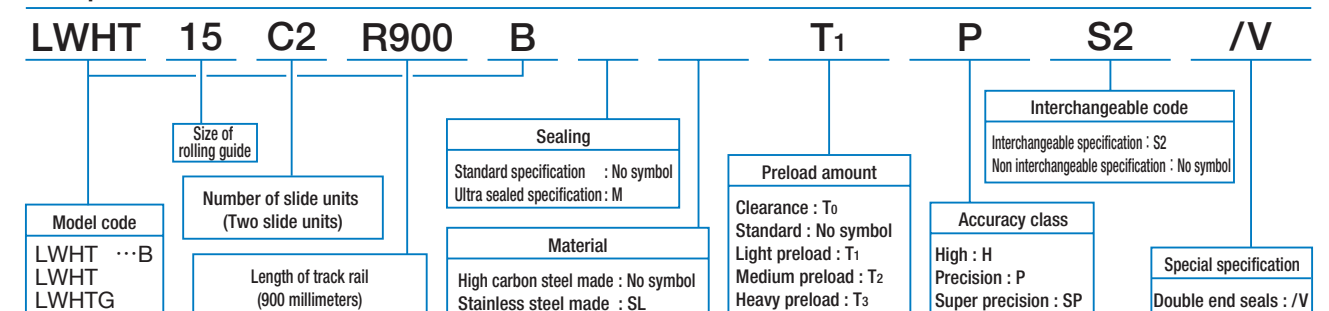

Flange type mounted from top  
**LWHT ...B**  
**LWHTG**  
**LWHT ...SL** (Stainless steel made)  
**LWHT ...M** (Ultra sealed type)

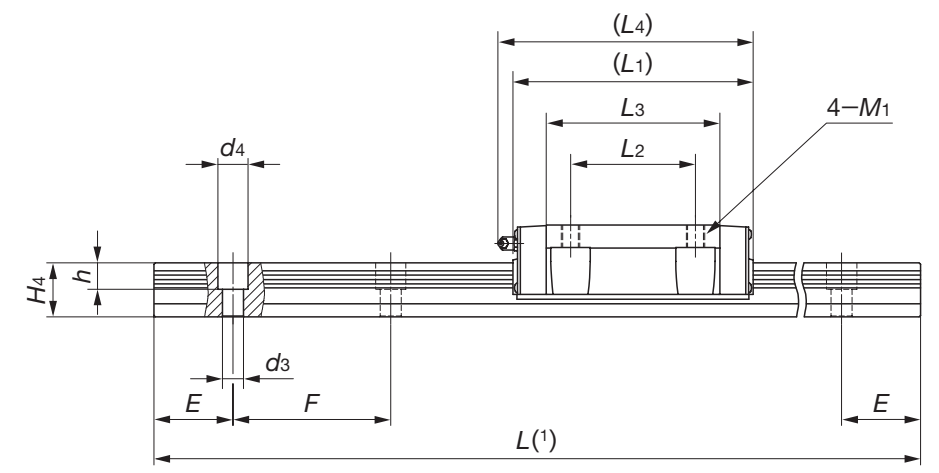
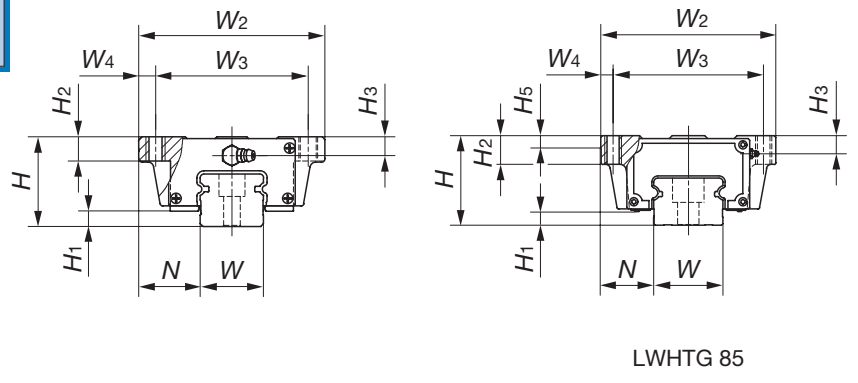

Model number	Interchangeable	Mass (Ref.)		Dimensions of assembly mm			Dimensions of slide unit mm																				
		Slide unit kg	Track rail kg/m	H	H <sub>1</sub>	N	W <sub>2</sub>	W <sub>3</sub>	W <sub>4</sub>	L <sub>1</sub>	L <sub>2</sub>	L <sub>3</sub>	L <sub>4</sub>	M <sub>1</sub>													
LWHT 30...B	☆	1.28	4.82	42	7	31	90	72	9	113	52	80.6	124	M 10													
LWHT 30...SL	☆																										
LWHT 30...M																											
LWHTG 30	☆	1.69								139		106.6	150														
LWHT 35...B	☆	1.79	6.85	48	8	33	100	82	9	123	62	86.2	135	M 10													
LWHT 35...M																											
LWHTG 35	☆														2.35								151		114	163	
LWHT 45...B	☆	3.17	10.7	60	10	37.5	120	100	10	147	80	103.4	158	M 12													
LWHT 45...M																											
LWHTG 45	☆														4.34								190		146.6	201	
LWHT 55...B	☆	5.30	15.5	70	13	43.5	140	116	12	183	95	132	194	M 14													
LWHTG 55	☆														7.40								235		183.6	246	
LWHT 65...B	☆														12.3								229		164	239	
LWHTG 65	☆	17.6	22.2	90	14	53.5	170	142	14	303	110	238.8	313	M 16													
LWHTG 85		25.9	34.6	110	16	65	215	185	15	318	140	240	—	M 20													

H <sub>2</sub>	H <sub>3</sub>	H <sub>5</sub>	Dimensions of track rail mm							Mounting bolt for track rail mm Bolt size × length	Basic dynamic load rating <sup>(2)</sup> C N	Basic static load rating <sup>(2)</sup> C <sub>0</sub> N	Static moment rating <sup>(2)</sup>		
			W	H <sub>4</sub>	d <sub>3</sub>	d <sub>4</sub>	h	E	F				T <sub>0</sub> N·m	T <sub>x</sub> N·m	T <sub>y</sub> N·m
10	8	—	28	25	9	14	12	40	80	M 8×28	35 400	40 700	623	536 2 820	536 2 820
											42 700	53 200	814	894 4 460	894 4 460
13	10	—	34	28	9	14	12	40	80	M 8×28	48 700	53 700	823	631 3 480	579 3 190
											59 500	71 600	1 100	1 090 5 570	1 000 5 110
15	13	—	45	34	14	20	17	52.5	105	M12×35	74 600	80 200	1 610	1 150 6 190	1 060 5 690
											95 200	114 000	2 280	2 240 11 100	2 050 10 200
17	14	—	53	41	16	23	20	60	120	M14×45	113 000	121 000	2 870	2 210 11 600	2 030 10 600
											142 000	168 000	3 970	4 120 20 200	3 780 18 500
23	20	—	63	48	18	26	22	75	150	M16×50	176 000	184 000	5 180	4 130 22 000	3 790 20 200
											229 000	269 000	7 560	8 530 41 500	7 810 38 100
35	22	15	85	58	26	39	30	90	180	M24×60	374 000	384 000	11 900	11 100 55 100	11 100 55 300

Note<sup>(1)</sup>: Track rail lengths are shown in Table 11.1 on page B-88, Table 11.2 on page B-89 and Table 11.3 on page B-90.  
<sup>(2)</sup>: The directions of basic dynamic load rating (C), basic static load rating (C<sub>0</sub>) and static moment rating (T<sub>0</sub>, T<sub>x</sub>, T<sub>y</sub>) are shown in the sketches below. The upper values in the T<sub>x</sub> and T<sub>y</sub> columns apply to one slide unit, and the lower values apply to two slide units in close contact.  
 Remark 1: The mark ☆ indicates that interchangeable specification products are available.  
 2: The appended track rail mounting bolts are hexagon socket head bolts of JIS B 1176 or equivalent. For stainless steel type Linear Way H, stainless steel bolts are appended.  
 3: For grease nipple specifications, see page 97.

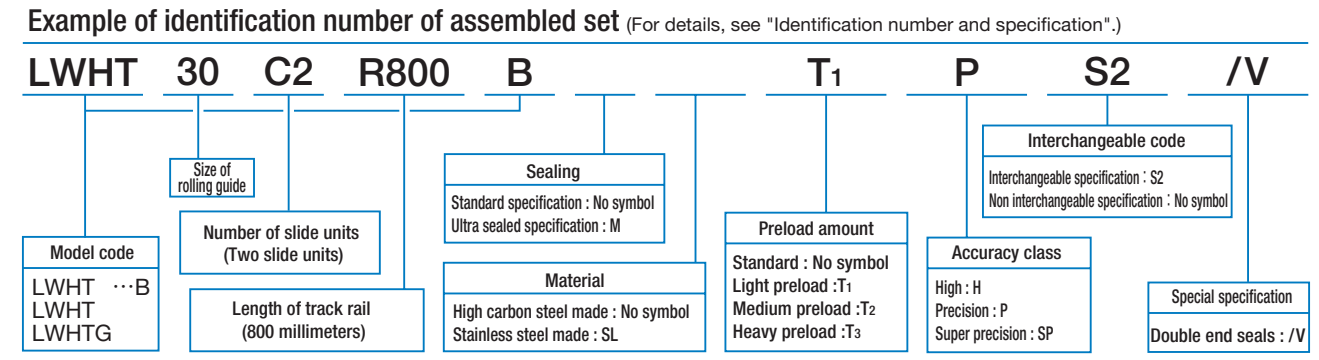
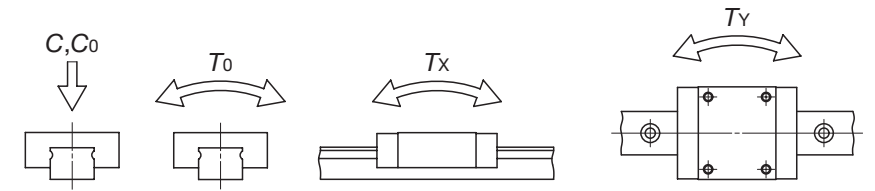

B  
 LWHT, LWHTG, LWHD, LWHS, LWHY



Block type mounted from top  
**LWHD ...B**  
**LWHDG**  
**LWHDG...SL** (Stainless steel made)  
**LWHD ...SL** (Stainless steel made)  
**LWHDG...SL** (Stainless steel made)  
**LWHD ...M** (Ultra sealed type)

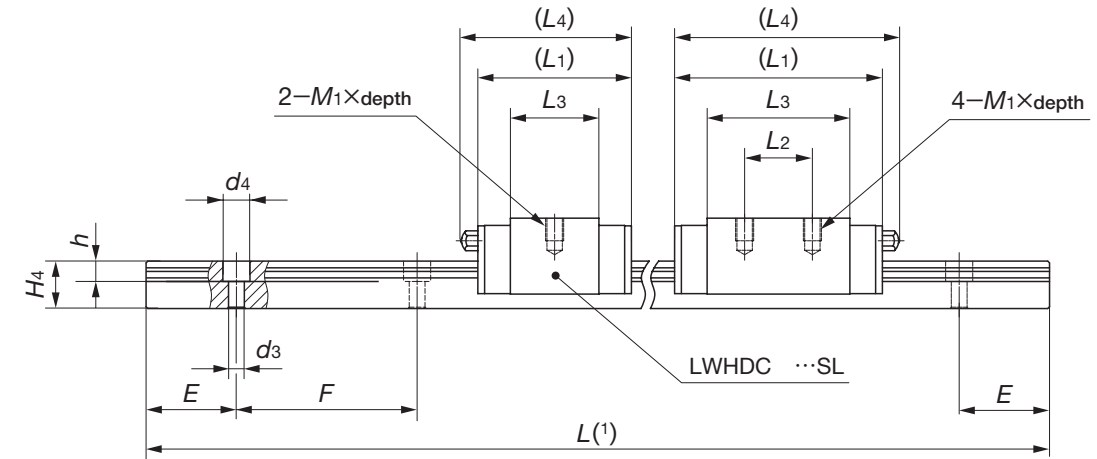
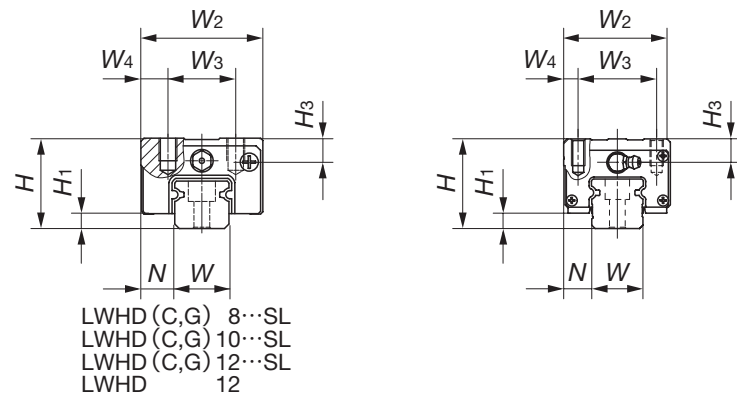

Model number	Interchangeable	Mass (Ref.)		Dimensions of assembly mm			Dimensions of slide unit mm							
		Slide unit kg	Track rail kg/m	H	H <sub>1</sub>	N	W <sub>2</sub>	W <sub>3</sub>	W <sub>4</sub>	L <sub>1</sub>	L <sub>2</sub>	L <sub>3</sub>	L <sub>4</sub>	M <sub>1</sub> ×depth
LWHDG 8...SL	☆	0.008	0.32	11	2.1	4	16	10	3	18	—	9.0	—	M2 × 2.5
LWHD 8...SL	☆	0.013								24	10	15.3		
LWHDG 8...SL	☆	0.018								30.5	21.7			
LWHDG 10...SL	☆	0.018	0.47	13	2.4	5	20	13	3.5	24	—	13.4	—	M2.6 × 3
LWHD 10...SL	☆	0.027								32	12	21.4		
LWHDG 10...SL	☆	0.036								40	29.4			
LWHDG 12...SL	☆	0.058	0.86	20	3.2	7.5	27	15	6	34	—	19.6	38	M4 × 5
LWHD 12	☆	0.091								46	15	31.6	50	
LWHDG 12...SL	☆	0.118								58	43.6	62		
LWHD 15...B	☆	0.23	1.47	28	4.5	9.5	34	26	4	66	26	44.6	69	M4 × 10
LWHD 15...M	☆													
LWHD 25...B	☆	0.65	3.50	40	6.5	12.5	48	35	6.5	95	35	64.7	106	M6 × 12
LWHD 25...M	☆													
LWHDG 25	☆	0.80								118	50	87.4	129	

H <sub>3</sub>	Dimensions of track rail mm								Mounting bolt for track rail mm Bolt size × length	Basic dynamic load rating <sup>(2)</sup> C N	Basic static load rating <sup>(2)</sup> C <sub>0</sub> N	Static moment rating <sup>(2)</sup>		
	W	H <sub>4</sub>	d <sub>3</sub>	d <sub>4</sub>	h	E	F	T <sub>0</sub> N·m				T <sub>x</sub> N·m	T <sub>y</sub> N·m	
3	8	6	2.4	4.2	2.3	10	20	M2 × 8	1 050	1 270	5.3	2.2	1.8	
												15.5	13.0	
												4.7	26.9	
3.5	10	7	3.5	6	3.5	12.5	25	M3 × 8	1 910	2 970	12.3	10.4	8.8	
												55.4	46.4	
												4.8	31.2	
5	12	10.5	3.5	6	4.5	20	40	M3 × 12	1 920	2 350	12.2	5.8	4.8	
												37.1	31.2	
												11.1	61.9	
8.5	15	15	4.5	8	6	30	60	M4 × 16	2 640	3 700	19.2	13.3	11.1	
												73.8	20.0	
												103	103	
10.5	23	22	7	11	9	30	60	M6 × 22	4 560	5 300	32.8	19.4	16.3	
												117	98.5	
												37.5	199	
10.5	23	22	7	11	9	30	60	M6 × 22	11 600	13 400	112	95.6	95.6	
												556	556	
10.5	23	22	7	11	9	30	60	M6 × 22	25 200	28 800	362	309	309	
												1 690	1 690	
10.5	23	22	7	11	9	30	60	M6 × 22	30 800	38 300	483	533	533	
												2 740	2 740	

Note<sup>(1)</sup>: Track rail lengths are shown in Table 11.1 on page B-88, Table 11.2 on page B-89 and Table 11.3 on page B-90.  
 (2): The directions of basic dynamic load rating (C), basic static load rating (C<sub>0</sub>) and static moment rating (T<sub>0</sub>, T<sub>x</sub>, T<sub>y</sub>) are shown in the sketches below. The upper values in the T<sub>x</sub> and T<sub>y</sub> columns apply to one slide unit, and the lower values apply to two slide units in close contact.

Remark 1: The mark ☆ indicates that interchangeable specification products are available.  
 2: The appended track rail mounting bolts are hexagon socket head bolts of JIS B 1176 or equivalent. For stainless steel type Linear Way H, stainless steel bolts are appended.  
 3: For grease nipple and oil hole specifications, see page 97.  
 4: LWHD8...SL and LWHD10...SL are provided with an oil hole.

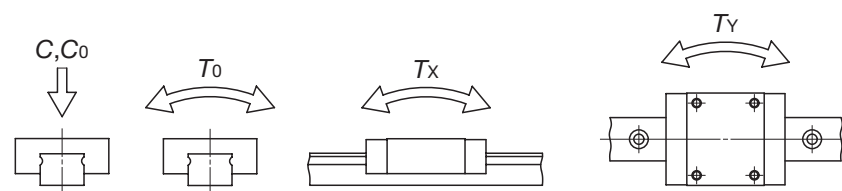

Example of identification number of assembled set (For details, see "Identification number and specification".)

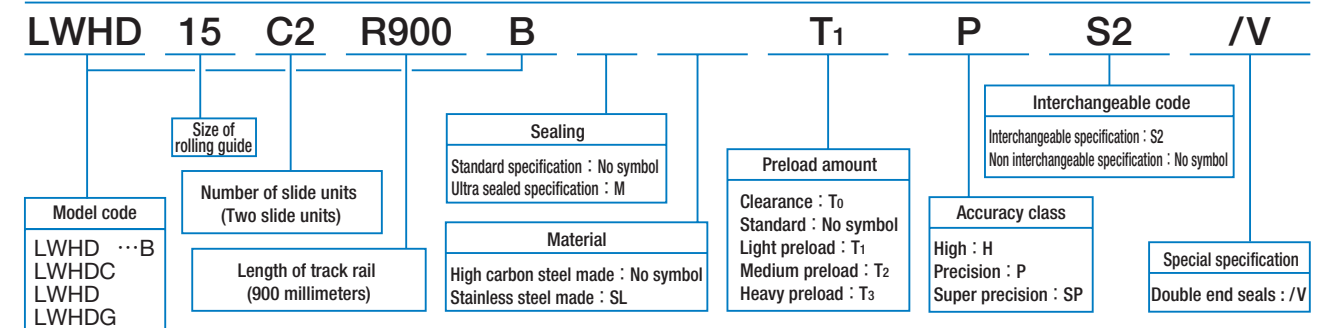

Block type mounted from top  
**LWHD ...B**  
**LWHDG**  
**LWHD ...M** (Ultra sealed type)

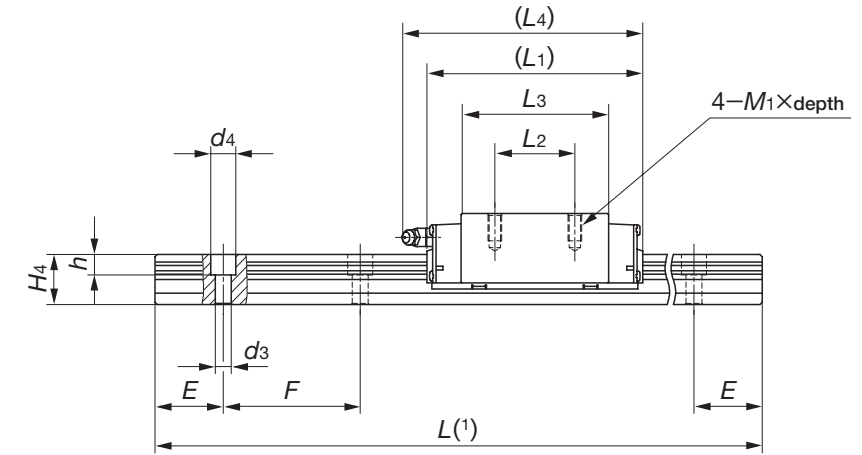
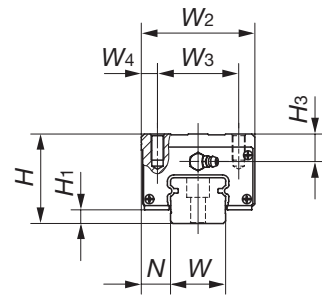

Model number	Interchangeable	Mass (Ref.)		Dimensions of assembly mm			Dimensions of slide unit mm							
		Slide unit kg	Track rail kg/m	H	H <sub>1</sub>	N	W <sub>2</sub>	W <sub>3</sub>	W <sub>4</sub>	L <sub>1</sub>	L <sub>2</sub>	L <sub>3</sub>	L <sub>4</sub>	M <sub>1</sub> × depth
LWHD 30...B	☆	1.12	4.82	45	7	16	60	40	10	113	40	80.6	124	M8 × 16
LWHD 30...M	☆									139	60	106.6	150	
LWHDG 30	☆	1.44	6.85	55	8	18	70	50	10	123	50	86.2	135	M8 × 16
LWHD 35...B	☆	1.74								151	72	114	163	
LWHD 35...M	☆	2.26	10.7	70	10	20.5	86	60	13	147	60	103.4	158	M10 × 20
LWHDG 35	☆	4.57								190	80	146.6	201	
LWHD 45...B	☆	3.30	15.5	80	13	23.5	100	75	12.5	183	75	132	194	M12 × 25
LWHD 45...M	☆									235	95	183.6	246	
LWHDG 45	☆	4.57	22.2	90	14	31.5	126	76	25	229	70	164	239	M16 × 30
LWHD 55...B	☆	5.36								303	120	238.8	313	
LWHDG 55	☆	7.20	14.3	90	14	31.5	126	76	25	229	70	164	239	M16 × 30
LWHD 65...B	☆	9.80								303	120	238.8	313	
LWHDG 65	☆	14.3	14.3	90	14	31.5	126	76	25	229	70	164	239	M16 × 30
LWHD 65...M	☆	14.3								303	120	238.8	313	

H <sub>3</sub>	Dimensions of track rail mm								Mounting bolt for track rail mm Bolt size × length	Basic dynamic load rating <sup>(2)</sup> C N	Basic static load rating <sup>(2)</sup> C <sub>0</sub> N	Static moment rating <sup>(2)</sup>		
	W	H <sub>4</sub>	d <sub>3</sub>	d <sub>4</sub>	h	E	F	T <sub>0</sub> N·m				T <sub>x</sub> N·m	T <sub>y</sub> N·m	
11	28	25	9	14	12	40	80	M8 × 28	35 400	40 700	623	536 2 820	536 2 820	
									42 700	53 200	814	894 4 460	894 4 460	
17	34	28	9	14	12	40	80	M8 × 28	48 700	53 700	823	631 3 480	579 3 190	
									59 500	71 600	1 100	1 090 5 570	1 000 5 110	
23	45	34	14	20	17	52.5	105	M12 × 35	74 600	80 200	1 610	1 150 6 190	1 060 5 690	
									95 200	114 000	2 280	2 240 11 100	2 050 10 200	
24	53	41	16	23	20	60	120	M14 × 45	113 000	121 000	2 870	2 210 11 600	2 030 10 600	
									142 000	168 000	3 970	4 120 20 200	3 780 18 500	
20	63	48	18	26	22	75	150	M16 × 50	176 000	184 000	5 180	4 130 22 000	3 790 20 200	
									229 000	269 000	7 560	8 530 41 500	7 810 38 100	

Note<sup>(1)</sup>: Track rail lengths are shown in Table 11.1 on page B-88, Table 11.2 on page B-89 and Table 11.3 on page B-90.  
<sup>(2)</sup>: The directions of basic dynamic load rating (C), basic static load rating (C<sub>0</sub>) and static moment rating (T<sub>0</sub>, T<sub>x</sub>, T<sub>y</sub>) are shown in the sketches below. The upper values in the T<sub>x</sub> and T<sub>y</sub> columns apply to one slide unit, and the lower values apply to two slide units in close contact.  
 Remark 1: The mark ☆ indicates that interchangeable specification products are available.  
 2: The appended track rail mounting bolts are hexagon socket head bolts of JIS B 1176 or equivalent. For stainless steel type Linear Way H, stainless steel bolts are appended.  
 3: For grease nipple specifications, see page 97.

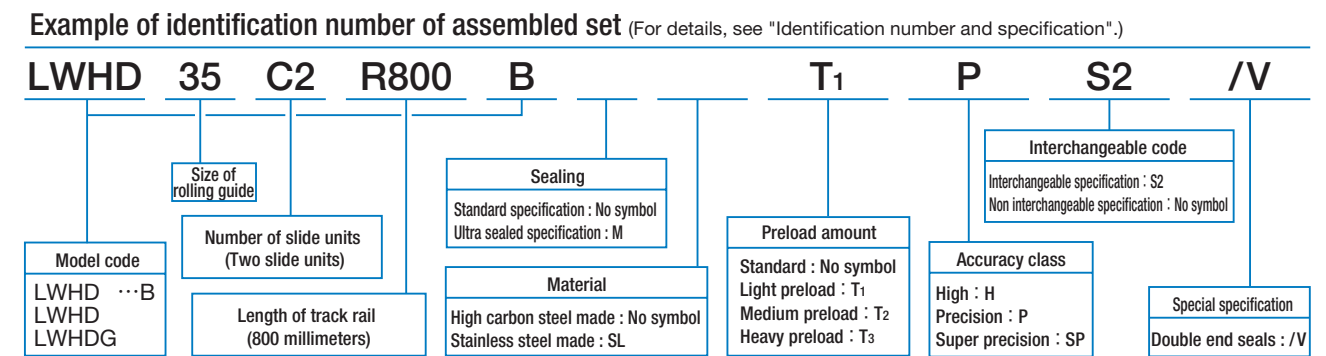
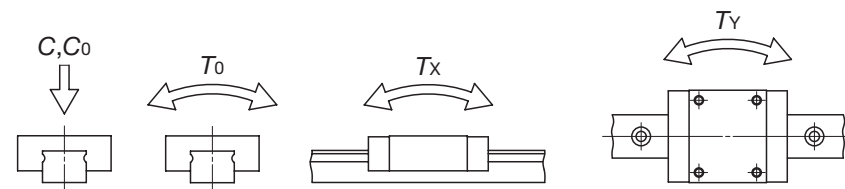

Compact block type mounted from top  
**LWHS ...B**  
**LWHS**  
**LWHS ...SL** (Stainless steel made)  
**LWHS ...M** (Ultra sealed type)

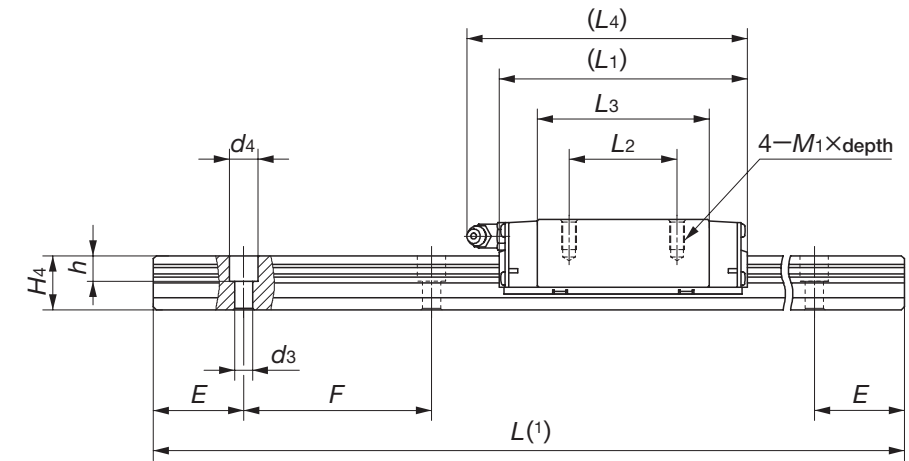
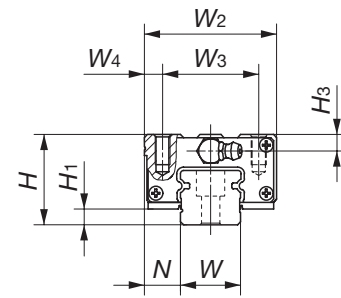

Model number	Interchangeable	Mass (Ref.)		Dimensions of assembly mm			Dimensions of slide unit mm							
		Slide unit kg	Track rail kg/m	H	H <sub>1</sub>	N	W <sub>2</sub>	W <sub>3</sub>	W <sub>4</sub>	L <sub>1</sub>	L <sub>2</sub>	L <sub>3</sub>	L <sub>4</sub>	M <sub>1</sub> × depth
LWHS 15...B	☆	0.18	1.47	24	4.5	9.5	34	26	4	66	26	44.6	69	M4 × 8
LWHS 15...SL	☆													
LWHS 15...M														
LWHS 20...B	☆	0.36	2.56	30	5	12	44	32	6	83	36	57.2	95	M5 × 10
LWHS 20...SL	☆													
LWHS 20...M														
LWHS 20...M	☆	0.53								112	50	86	124	
LWHS 25...B	☆	0.55	3.50	36	6.5	12.5	48	35	6.5	95	35	64.7	106	M6 × 12
LWHS 25...SL	☆													
LWHS 25...M														
LWHS 25...M	☆	0.67								118	50	87.4	129	
LWHS 30...B	☆	1.00	4.82	42	7	16	60	40	10	113	40	80.6	124	M8 × 16
LWHS 30...SL	☆													
LWHS 30...M														
LWHS 30...M	☆	1.29								139	60	106.6	150	

Note(1) : Track rail lengths are shown in Table 11.1 on page B-88, Table 11.2 on page B-89 and Table 11.3 on page B-90.  
 (2) : The directions of basic dynamic load rating (C), basic static load rating (C<sub>0</sub>) and static moment rating (T<sub>0</sub>, T<sub>x</sub>, T<sub>y</sub>) are shown in the sketches below. The upper values in the T<sub>x</sub> and T<sub>y</sub> columns apply to one slide unit, and the lower values apply to two slide units in close contact.

Remark 1 : The mark ☆ indicates that interchangeable specification products are available.  
 2 : The appended track rail mounting bolts are hexagon socket head bolts of JIS B 1176 or equivalent.  
 For stainless steel type Linear Way H, stainless steel bolts are appended.  
 3 : For grease nipple specifications, see page 97.

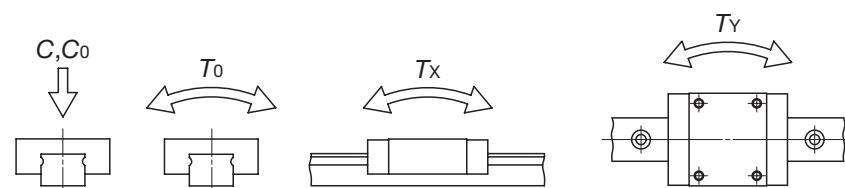

H <sub>3</sub>	Dimensions of track rail mm								Mounting bolt for track rail mm Bolt size × length	Basic dynamic load rating <sup>(2)</sup> C N	Basic static load rating <sup>(2)</sup> C <sub>0</sub> N	Static moment rating <sup>(2)</sup>		
	W	H <sub>4</sub>	d <sub>3</sub>	d <sub>4</sub>	h	E	F	T <sub>0</sub> N·m				T <sub>x</sub> N·m	T <sub>y</sub> N·m	
4.5	15	15	4.5	8	6	30	60	M4 × 16	11 600	13 400	112	95.6 556	95.6 556	
5.5	20	18	6	9.5	8.5	30	60	M5 × 18	18 100	21 100	232	195 1 090	195 1 090	
									24 100	31 700	349	421 2 140	421 2 140	
6.5	23	22	7	11	9	30	60	M6 × 22	25 200	28 800	362	309 1 690	309 1 690	
									30 800	38 300	483	533 2 740	533 2 740	
8	28	25	9	14	12	40	80	M8 × 28	35 400	40 700	623	536 2 820	536 2 820	
									42 700	53 200	814	894 4 460	894 4 460	

Example of identification number of assembled set (For details, see "Identification number and specification".)

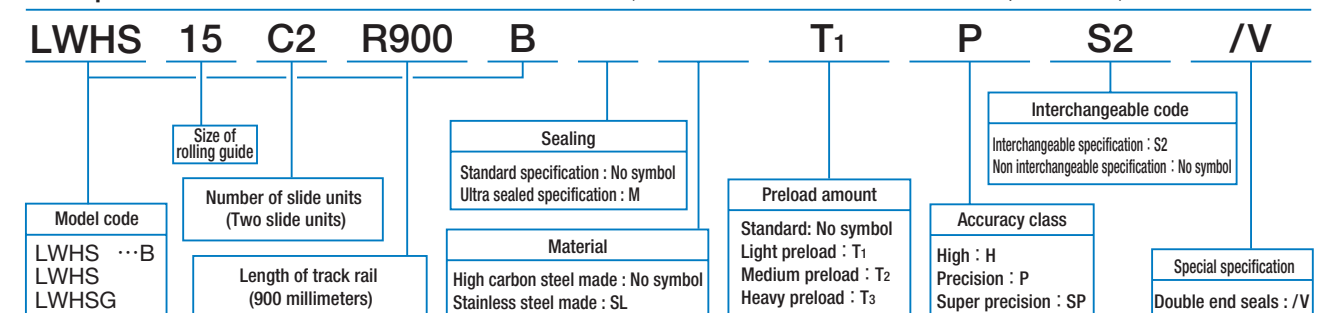

Side mounting type  
**LWHY**

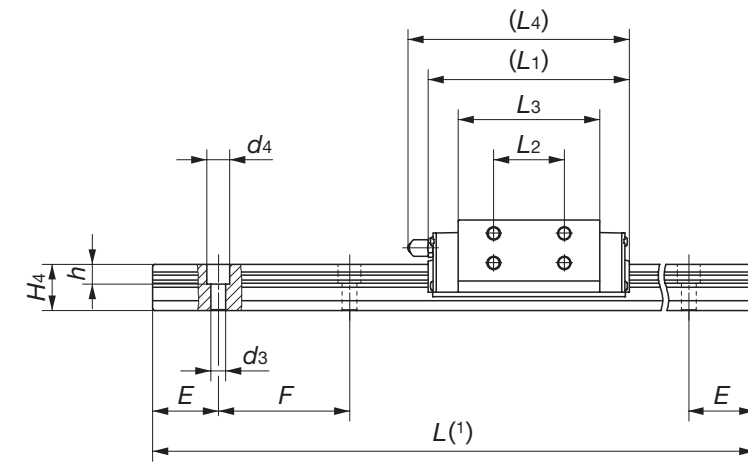
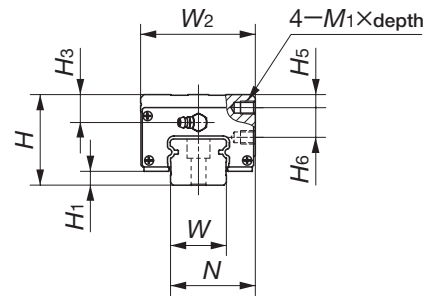

Model number	Mass (Ref.)		Dimensions of assembly mm			Dimensions of slide unit mm						
	Slide unit kg	Track rail kg/m	H	H <sub>1</sub>	N	W <sub>2</sub>	L <sub>1</sub>	L <sub>2</sub>	L <sub>3</sub>	L <sub>4</sub>	M1×depth	H <sub>3</sub>
<b>LWHY 15</b>	0.23	1.47	28	4.5	24.3	34	66	18	44.6	69	M 4× 4	8.5
<b>LWHY 20</b>	0.36	2.56	30	5	31.5	43.7	83	25	57.2	95	M 5× 5	5.5
<b>LWHY 25</b>	0.65	3.50	40	6.5	35	47.7	95	30	64.7	106	M 6× 6	10.5
<b>LWHY 30</b>	1.12	4.82	45	7	43.5	59.7	113	40	80.6	124	M 6× 7	11
<b>LWHY 35</b>	1.74	6.85	55	8	51.5	69.7	123	43	86.2	135	M 8× 9	17
<b>LWHY 45</b>	3.30	10.7	70	10	65	85.7	147	55	103.4	158	M10×11	23
<b>LWHY 55</b>	5.36	15.5	80	13	76	99.7	183	70	132	194	M12×13	24
<b>LWHY 65</b>	9.80	22.2	90	14	94.5	126	229	85	164	239	M16×16	20

Note(1) : Track rail lengths are shown in Table 11.1 on page B-88.  
 (2) : The directions of basic dynamic load rating (C), basic static load rating (C<sub>0</sub>) and static moment rating (T<sub>0</sub>, T<sub>x</sub>, T<sub>y</sub>) are shown in the sketches below. The upper values in the T<sub>x</sub> and T<sub>y</sub> columns apply to one slide unit, and the lower values apply to two slide units in close contact.  
 Remark 1 : The appended track rail mounting bolts are hexagon socket head bolts of JIS B 1176 or equivalent.  
 2 : For grease nipple specifications, see page 97.

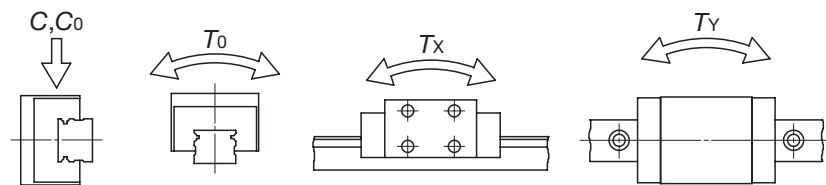

		Dimensions of track rail mm							Mounting bolt for track rail mm Bolt size × length	Basic dynamic load rating <sup>(2)</sup> C N	Basic static load rating <sup>(2)</sup> C <sub>0</sub> N	Static moment rating <sup>(2)</sup>		
H <sub>5</sub>	H <sub>6</sub>	W	H <sub>4</sub>	d <sub>3</sub>	d <sub>4</sub>	h	E	F				T <sub>0</sub> N·m	T <sub>x</sub> N·m	T <sub>y</sub> N·m
4	9	15	15	4.5	8	6	30	60	M 4×16	9 360	13 900	116	99.2 577	99.2 577
4	10	20	18	6	9.5	8.5	30	60	M 5×18	14 500	21 900	241	202 1 130	202 1 130
6	12	23	22	7	11	9	30	60	M 6×22	20 100	29 800	376	320 1 750	320 1 750
8	14	28	25	9	14	12	40	80	M 8×28	28 100	42 200	646	556 2 930	556 2 930
8	18	34	28	9	14	12	40	80	M 8×28	31 200	43 500	878	665 3 600	601 3 310
10	22	45	34	14	20	17	52.5	105	M12×35	47 600	65 000	1 720	1 200 6 420	1 100 5 900
12	25	53	41	16	23	20	60	120	M14×45	71 200	98 300	3 050	2 300 12 000	2 110 11 000
12	30	63	48	18	26	22	75	150	M16×50	110 000	149 000	5 510	4 280 22 800	3 930 21 000

Example of identification number of assembled set (For details, see "Identification number and specification".)

