

# Linear Way E

## LWE/LWET/LWES

**IKO Linear Way E** is a linear motion rolling guide, featuring a compact slide unit which performs endless linear motion along a track rail. Two rows of steel balls are arranged in four point contact with the raceways. This design ensures stable high accuracy and rigidity in operations even under fluctuating loads with changing direction and magnitude or complex loads. A wide range of variations in shapes and sizes are available. This series is a compact type suitable for general applications.

### Interchangeable

Linear Way E includes interchangeable specification products. The dimensions of slide units and track rails of this specification are individually controlled, so that the slide units and track rails can be combined, added or exchanged freely.

### Variable lengths of slide unit

In addition to the standard slide unit, a short type slide unit and a high rigidity long type slide unit both having the same sectional dimensions with the standard slide unit are available.

### Compact design

Lower, narrower, and shorter. Compactness has been pursued in every dimension.

### Stainless steel type

The stainless steel type has excellent corrosion resistance and is most suitable for machines and equipment used in clean environments, for example, medical equipment, disk read devices and semiconductor manufacturing equipment.

### Flange type and block type

Slide units are available in three different sectional shapes; two flange types for different mounting directions and one block type with a narrow width.

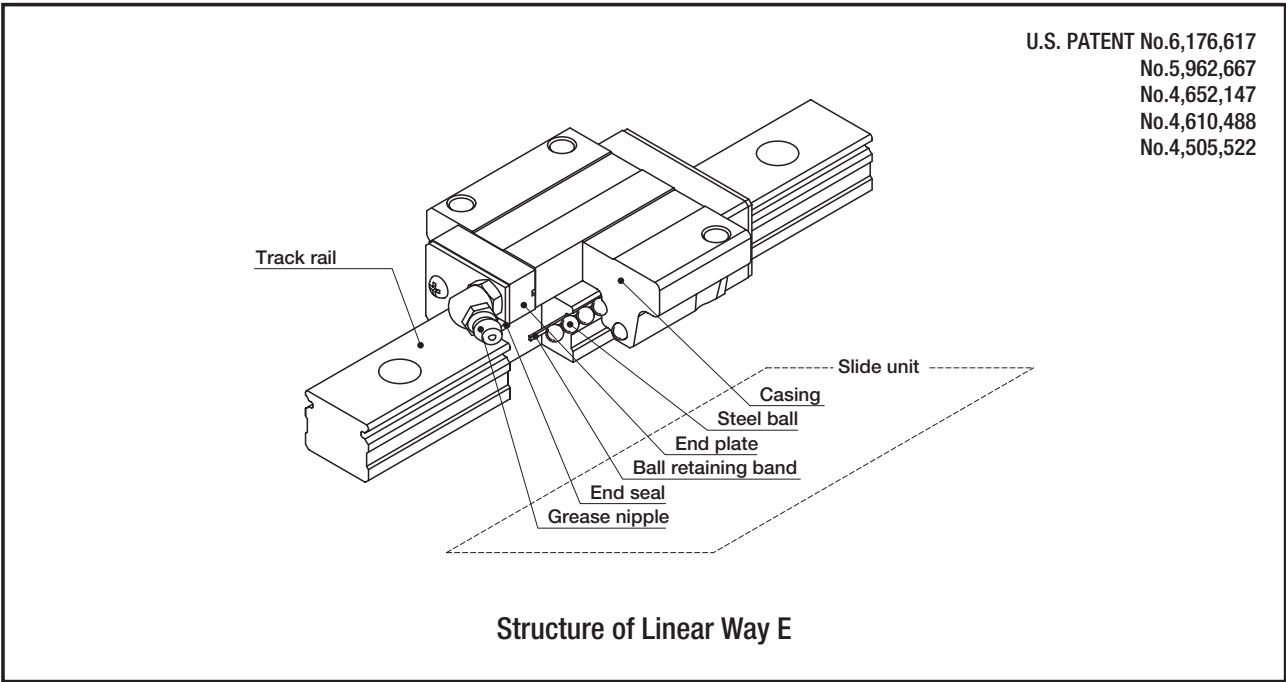

# Linear Way E series

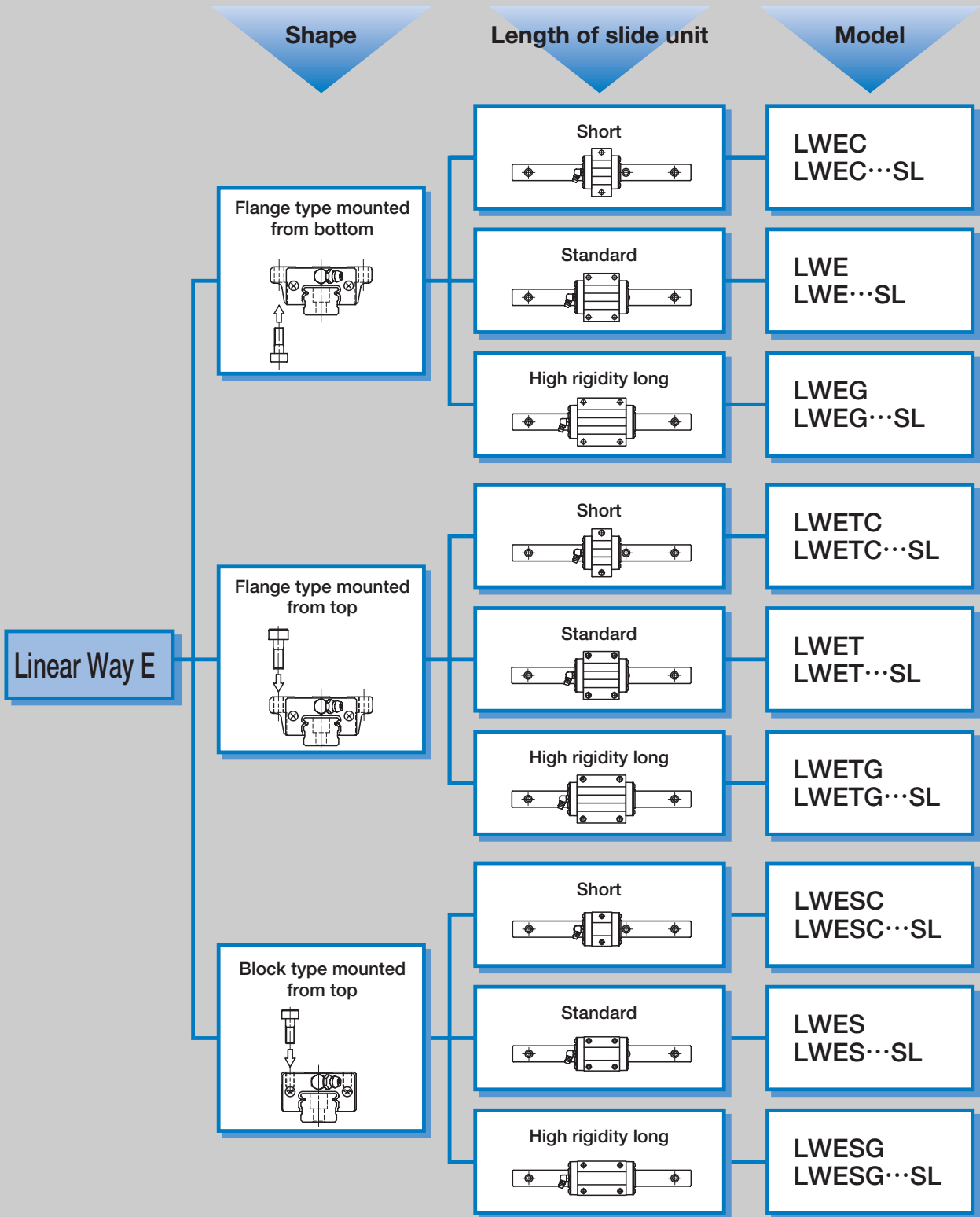

Remark : Models with "SL" are stainless steel type.

B  
LWE, LWET, LWES

## ● Identification number and specification

The specification of Linear Way E is indicated by the identification number, consisting of a model code, a size, a part code, a material symbol, a preload symbol, a classification symbol, an interchangeable code and any supplemental codes. For details of each specification, see page 76.

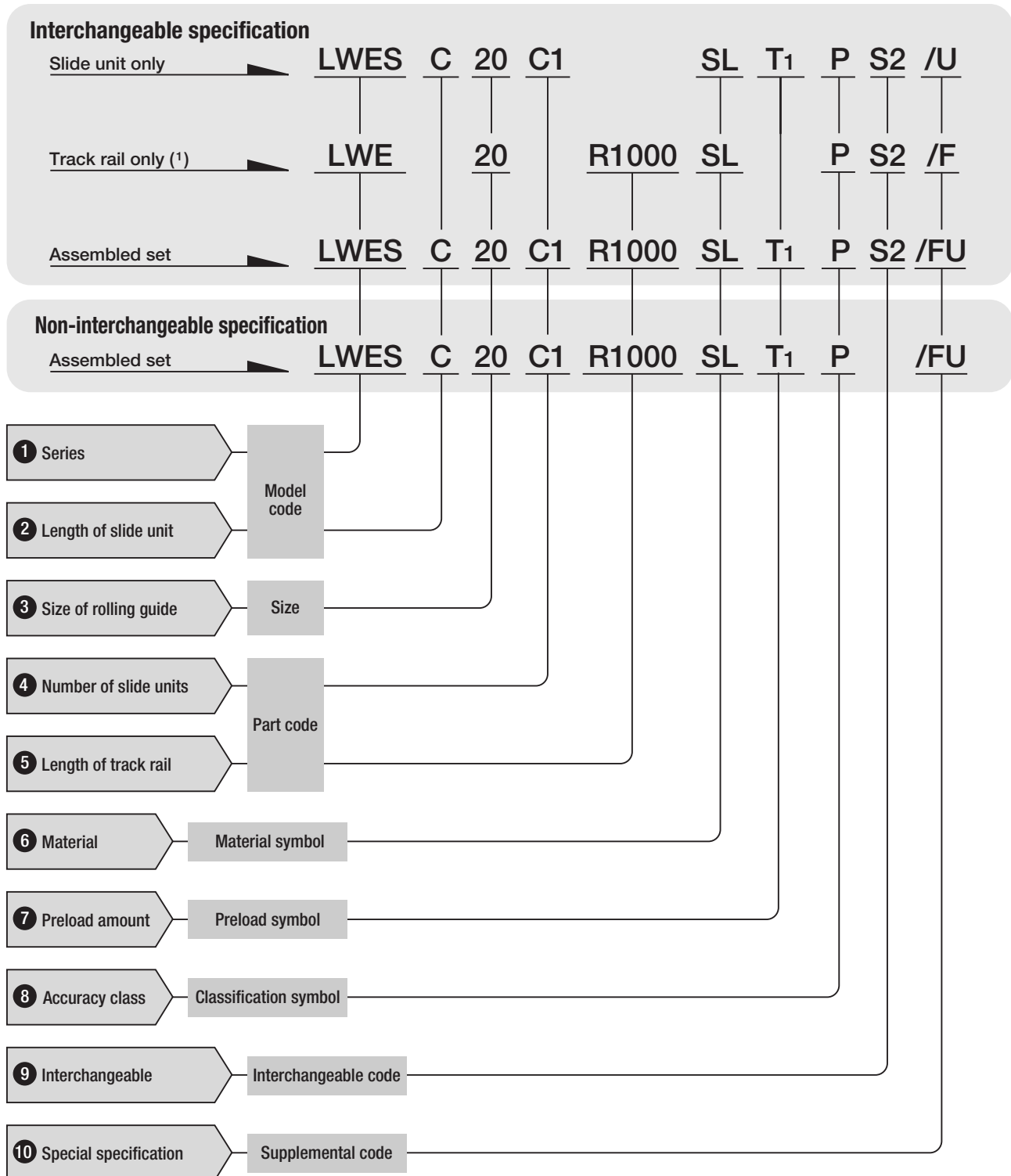

Note(1) : For the model code of a single track rail of interchangeable specification, indicate "LWE" regardless of the slide unit type to be combined.

**1 Series**

Flange type mounted from bottom : **LWE**  
 Flange type mounted from top : **LWET**  
 Block type mounted from top : **LWES**

**2 Length of slide unit**

Short : **C**  
 Standard : No symbol  
 High rigidity long : **G**

For available slide unit models, materials and sizes, see Tables 1.1 to 1.3.

**3 Size of rolling guide**

**4 Number of slide units**

Assembled set : **C**○  
 Slide unit only : **C1**

For an assembled set, indicate the number of slide units assembled on one track rail. For a slide unit, only "C1" can be indicated.

**5 Length of track rail**

Assembled set : **R**○  
 Track rail only : **R**○

Indicate the length of track rail in mm. For standard and maximum lengths, see "Track rail length" on page B-40 to B-41.

**6 Material**

High carbon steel made : No symbol  
 Stainless steel made : **SL**

For available material types, see Tables 1.1, 1.2 and 1.3 on page B-32.

## Models and sizes of Linear Way E

Table 1.1 Flange type mounted from bottom

Model Size	High carbon steel made			Stainless steel made		
	Short LWEC	Standard LWE	High rigidity long LWEG	Short LWEC···SL	Standard LWE···SL	High rigidity long LWEG···SL
15	☆	☆	☆	☆	☆	☆
20	☆	☆	☆	☆	☆	☆
25	☆	☆	☆	☆	☆	☆
30	☆	☆	☆	☆	☆	☆
35	☆	☆	—	—	—	—
45	—	☆	—	—	—	—

Table 1.2 Flange type mounted from top

Model Size	High carbon steel made			Stainless steel made		
	Short LWETC	Standard LWET	High rigidity long LWETG	Short LWETC···SL	Standard LWET···SL	High rigidity long LWETG···SL
15	☆	☆	☆	☆	☆	☆
20	☆	☆	☆	☆	☆	☆
25	☆	☆	☆	☆	☆	☆
30	☆	☆	☆	☆	☆	☆
35	☆	☆	—	—	—	—
45	—	☆	—	—	—	—

Table 1.3 Block type mounted from top

Model Size	High carbon steel made			Stainless steel made		
	Short LWESC	Standard LWES	High rigidity long LWESG	Short LWESC···SL	Standard LWES···SL	High rigidity long LWESG···SL
15	☆	☆	☆	☆	☆	☆
20	☆	☆	☆	☆	☆	☆
25	☆	☆	☆	☆	☆	☆
30	☆	☆	☆	☆	☆	☆
35	☆	☆	—	—	—	—
45	—	☆	—	—	—	—

Remark : The mark ☆ indicates that interchangeable specification products are available.

**7** Preload amount

Clearance : T<sub>c</sub>  
 Standard : No symbol  
 Light preload : T<sub>1</sub>  
 Medium preload : T<sub>2</sub>

Specify this item for an assembled set or a single slide unit.  
 For applicable combinations of accuracy and preload amount, see Table 2. For details of preload amount, see page 84.

**8** Accuracy class

Ordinary : No symbol  
 High : H  
 Precision : P  
 Super precision : SP

For applicable combinations of accuracy and preload amount, see Table 2. In case of interchangeable specification products, assemble slide units and track rails of the same class. For details of accuracy, see page 79.

**Table 2 Accuracy class and preload**

Accuracy class (Symbol) / Preload (Symbol)	Ordinary (No symbol)	High (H)	Precision (P)	Super precision (SP)
Clearance (T <sub>c</sub> )	☆	—	—	—
Standard (No symbol)	☆	☆	☆	○
Light preload (T <sub>1</sub> )	—	☆	☆	○
Medium preload (T <sub>2</sub> )	—	○	○	○

Remark : The mark ☆ indicates that interchangeable specification products are available.

**9** Interchangeable code

Select group 1 : S1  
 Select group 2 : S2

Specify this item for interchangeable specification products. Assemble track rails and slide units with the same interchangeable code. Performance and accuracy of "S1" group and "S2" group are the same.

**10** Special specification

For applicable special specifications, see Table 3. When several special specifications are required, see Table 4. For details of special specifications, see page 86.



Table 5.1 Female threads for bellows for flange type slide unit (Supplemental code /J, /JJ)

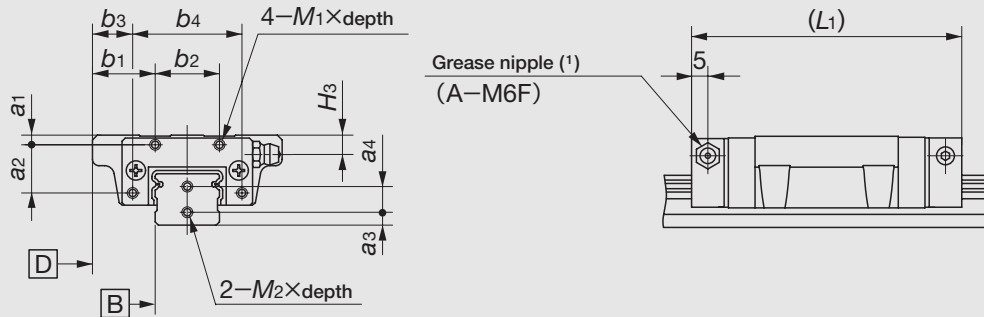

unit : mm

Model number	Slide unit									Track rail		
	a1	a2	b1	b2	b3	b4	M1×depth	L1 <sup>(2)</sup>	H3	a3	a4	M2×depth
<b>LWE (T) C 15</b>	3	12	18	16	12	28	M3×6	58	5.7	4	7	M3× 6
<b>LWE (T) 15</b>								74				
<b>LWE (T) G 15</b>								87				
<b>LWE (T) C 20</b>	3	15	19.5	20	12.5	34	M3×6	64	6	4	8	M3× 6
<b>LWE (T) 20</b>								83				
<b>LWE (T) G 20</b>								99				
<b>LWE (T) C 25</b>	3.5	17	23.5	26	16.5	40	M3×6	76	7	5	9	M4× 8
<b>LWE (T) 25</b>								100				
<b>LWE (T) G 25</b>								119				
<b>LWE (T) C 30</b>	5	17	28	34	20	50	M3×6	83	11	6	14	M4× 8
<b>LWE (T) 30</b>								112				
<b>LWE (T) G 30</b>								144				
<b>LWE (T) C 35</b>	6	20	30	40	20	60	M3×6	93	13	7	15	M4× 8
<b>LWE (T) 35</b>								126				
<b>LWE (T) 45</b>	7	26	35	50	23	74	M4×8	138	15	8	19	M5×10

Note<sup>(1)</sup> : The specification and mounting position of grease nipple are different from those of the standard specification product.  
 Size 15 models are provided with a special specification grease nipple (NPB2 type).  
 For details of dimensions, consult **IKO** for further information.

<sup>(2)</sup> : The values for a slide unit with female threads for bellows at both ends are shown.

Remark : The above table shows representative model numbers but is also applicable to stainless steel type models of the same size.



Table 5.2 Female threads for bellows for block type slide unit (Supplemental code /J, /JJ)

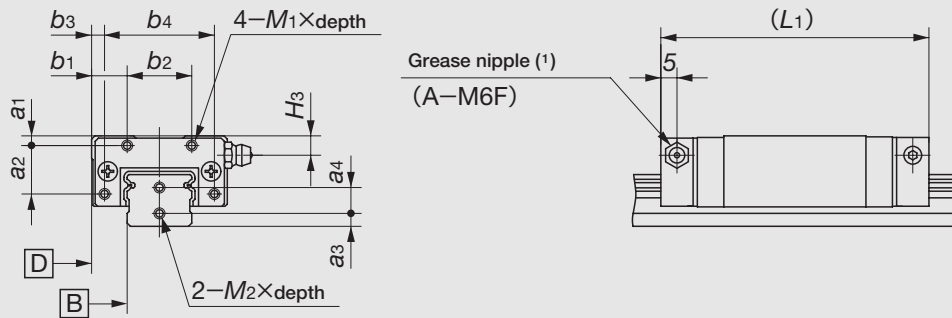

unit : mm

Model number	Slide unit							Track rail				
	a1	a2	b1	b2	b3	b4	M1×depth	L1 <sup>(2)</sup>	H3	a3	a4	M2×depth
<b>LWESC 15</b>	3	12	9	16	3	28	M3×6	58	5.7	4	7	M3× 6
<b>LWES 15</b>								74				
<b>LWESG 15</b>								87				
<b>LWESC 20</b>	3	15	11	20	4	34	M3×6	64	6	4	8	M3× 6
<b>LWES 20</b>								83				
<b>LWESG 20</b>								99				
<b>LWESC 25</b>	3.5	17	11	26	4	40	M3×6	76	7	5	9	M4× 8
<b>LWES 25</b>								100				
<b>LWESG 25</b>								119				
<b>LWESC 30</b>	5	17	13	34	5	50	M3×6	83	11	6	14	M4× 8
<b>LWES 30</b>								112				
<b>LWESG 30</b>								144				
<b>LWESC 35</b>	6	20	15	40	5	60	M3×6	93	13	7	15	M4× 8
<b>LWES 35</b>								126				
<b>LWES 45</b>	7	26	18	50	6	74	M4×8	138	15	8	19	M5×10

Note<sup>(1)</sup> : The specification and mounting position of grease nipple are different from those of the standard specification product.  
 Size 15 models are provided with a special specification grease nipple (NPB2 type).  
 For details of dimensions, consult **IKO** for further information.

<sup>(2)</sup> : The values for a slide unit with female threads for bellows at both ends are shown.

Remark : The above table shows representative model numbers but is also applicable to stainless steel type models of the same size.

Table 6 Recommended track rail mounting bolt size (Supplemental code /MA)

Model number	Recommended bolt size
<b>LWE 15</b>	M 3×16
	M 4×16 <sup>(1)</sup>
<b>LWE 20</b>	M 5×16
<b>LWE 25</b>	M 6×20
<b>LWE 30</b>	M 6×25
<b>LWE 35</b>	M 8×30
<b>LWE 45</b>	M10×35

Note<sup>(1)</sup> : Applicable to the track rail of supplemental code "/M4" of special specification.

Remark 1 : The above table shows representative model numbers but is applicable to all models of the same size.

2 : Hexagon socket head bolts of strength division 12.9 of JIS B 1176 are recommended.

3 : For stainless Linear Way E, stainless steel bolts are appended when specified supplemental code "/MA".

Table 7 Changed size of mounting holes (Supplemental code /M4)

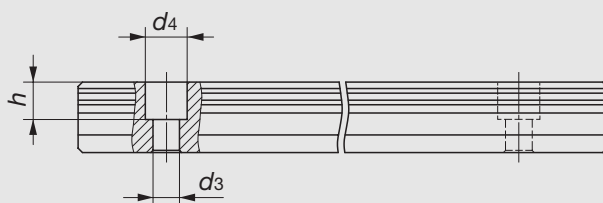

unit : mm

Model number	$d_3$	$d_4$	$h$
<b>LWE 15</b>	4.5	8	6

Remark : The above table shows a representative model number but is applicable to all models of size 15.

Table 8 Slide unit with Capillary plates (Supplemental code /Q)

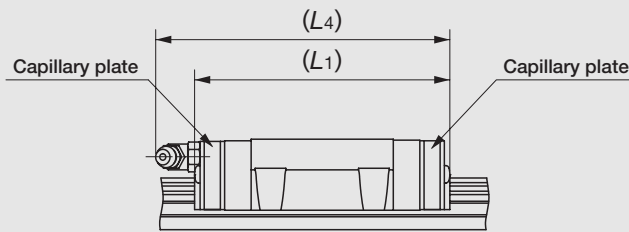

unit : mm

Model number	L <sub>1</sub>	L <sub>4</sub>
<b>LWEC 15</b>	52	55
<b>LWE 15</b>	68	71
<b>LWEG 15</b>	81	83
<b>LWEC 20</b>	58	71
<b>LWE 20</b>	78	91
<b>LWEG 20</b>	94	106
<b>LWEC 25</b>	70	83
<b>LWE 25</b>	94	107
<b>LWEG 25</b>	113	126

Model number	L <sub>1</sub>	L <sub>4</sub>
<b>LWEC 30</b>	80	91
<b>LWE 30</b>	109	119
<b>LWEG 30</b>	141	151
<b>LWEC 35</b>	90	102
<b>LWE 35</b>	123	135
<b>LWE 45</b>	138	148

Remark : The above table shows representative model numbers but is applicable to all models of the same size.

Table 9 H<sub>1</sub> dimension of slide unit with under seals (Supplemental code /U)

unit : mm

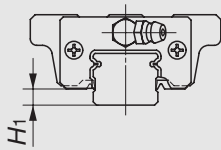

Model number	H <sub>1</sub>
<b>LWE 15</b>	5
<b>LWE 20</b>	5
<b>LWE 25</b>	6
<b>LWE 30</b>	7
<b>LWE 35</b>	8
<b>LWE 45</b>	10

Remark : The above table shows representative model numbers but is applicable to all models of the same size.

Table 10 Slide unit with double end seals (Supplemental code /V, /VV)

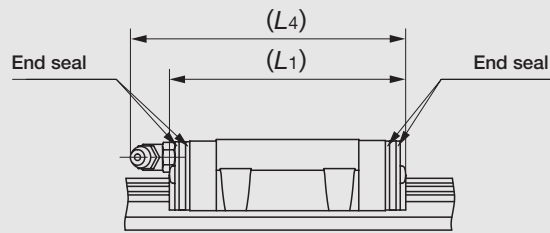

unit : mm

Model number	L <sub>1</sub>	L <sub>4</sub>
LWEC 15	48	50
LWE 15	64	66
LWEG 15	76	78
LWEC 20	54	68
LWE 20	73	87
LWEG 20	89	103
LWEC 25	67	80
LWE 25	91	104
LWEG 25	110	123

Model number	L <sub>1</sub>	L <sub>4</sub>
LWEC 30	78	89
LWE 30	107	118
LWEG 30	138	150
LWEC 35	88	101
LWE 35	121	134
LWE 45	137	148

Remark 1 : The above table shows representative model numbers but is applicable to all models of the same size.  
 2 : The values for a slide unit with double end seals at both ends are shown.

Table 11 Slide unit with scrapers (Supplemental code /Z, /ZZ)

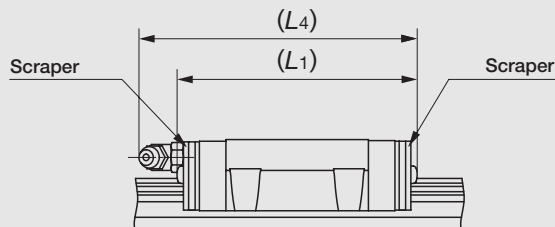

unit : mm

Model number	L <sub>1</sub>	L <sub>4</sub>
LWEC 15	48	50
LWE 15	64	66
LWEG 15	77	79
LWEC 20	55	69
LWE 20	75	88
LWEG 20	90	104
LWEC 25	69	81
LWE 25	93	105
LWEG 25	112	124

Model number	L <sub>1</sub>	L <sub>4</sub>
LWEC 30	79	90
LWE 30	108	119
LWEG 30	140	151
LWEC 35	89	101
LWE 35	122	134
LWE 45	138	148

Remark 1 : The above table shows representative model numbers but is applicable to all models of the same size.  
 2 : The values for a slide unit with scrapers at both ends are shown.

## ● Track rail length

Standard and maximum lengths of track rails are shown in Tables 12.1 and 12.2. Track rails in any length are also available. Simply indicate the necessary length of track rail in mm in the identification number. For the tolerances of  $E$  dimension and track rail length, consult **IKO** for further information.

- For non-interchangeable track rails longer than the maximum length shown in Tables 12.1 and 12.2, butt-jointing track rails are available upon request. In this case, indicate "/A" in the identification number.
- $E$  dimensions at both ends are the same and are within the standard range of  $E$  unless otherwise specified. To change these dimensions, specify the specified rail mounting hole positions "/E" of special specification. For details, see page 89.

Table 12.1 Standard and maximum lengths of high carbon steel track rails

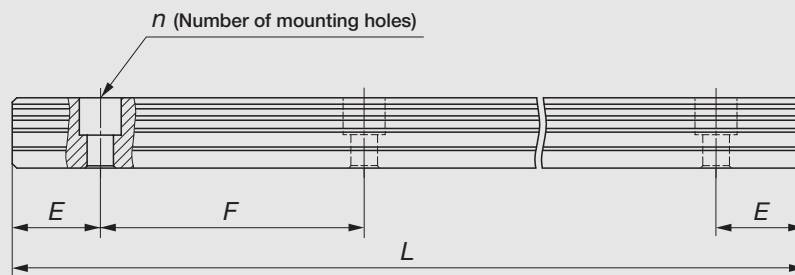

unit : mm

Item	Model number	LWE 15	LWE 20	LWE 25	LWE 30	LWE 35	LWE 45
Standard length $L$ ( $n$ )		160 ( 3)	220 ( 4)	220 ( 4)	280 ( 4)	280 ( 4)	570 ( 6)
		220 ( 4)	280 ( 5)	280 ( 5)	440 ( 6)	440 ( 6)	885 ( 9)
		280 ( 5)	340 ( 6)	340 ( 6)	600 ( 8)	600 ( 8)	1 200 (12)
		340 ( 6)	460 ( 8)	460 ( 8)	760 (10)	760 (10)	1 620 (16)
		460 ( 8)	640 (11)	640 (11)	1 000 (13)	1 000 (13)	2 040 (20)
		640 (11)	820 (14)	820 (14)	1 240 (16)	1 240 (16)	2 460 (24)
		820 (14)	1 000 (17)	1 000 (17)	1 640 (21)	1 640 (21)	2 985 (29)
		1 240 (21)	1 240 (21)	2 040 (26)	2 040 (26)		
			1 600 (27)	2 520 (32)	2 520 (32)		
				3 000 (38)	3 000 (38)		
Pitch of mounting holes $F$		60	60	60	80	80	105
$E$ <sup>(1)</sup>		20	20	20	20	20	22.5
Standard range of $E$ <sup>(2)</sup>	incl.	6	8	9	9	10	12
	under	36	38	39	49	50	64.5
Maximum length <sup>(3)</sup>		1 600 (2 980)	2 200 (2 980)	2 980 (4 000)	3 000 (3 960)	3 000 (3 960)	2 985 (3 930)

Note<sup>(1)</sup> : When specifying a butt-jointing interchangeable track rail (supplemental code "/T"), pay attention to the  $E$  dimension at the butt-jointing part.

<sup>(2)</sup> : Not applicable to the track rail with female threads for bellows (supplemental code "/J").

<sup>(3)</sup> : Track rails with the maximum lengths shown in parentheses can also be manufactured. Consult **IKO** for further information.

Remark : The above table shows representative model numbers but is applicable to all models of the same size.

Table 12.2 Standard and maximum lengths of stainless steel track rails

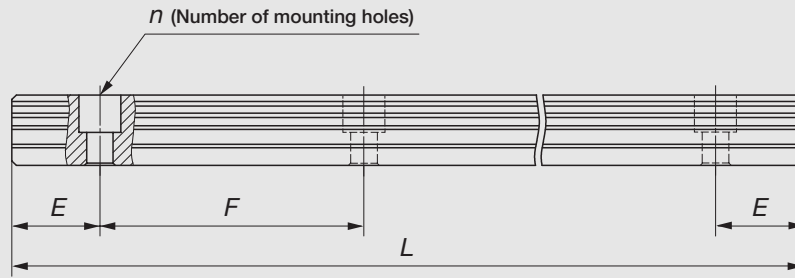

unit : mm

Item \ Model number	LWE 15...SL	LWE 20...SL	LWE 25...SL	LWE 30...SL
Standard length $L (n)$	160( 3) 220( 4) 280( 5) 340( 6) 460( 8) 640(11) 820(14)	220( 4) 280( 5) 340( 6) 460( 8) 640(11) 820(14) 1 000(17)	220( 4) 280( 5) 340( 6) 460( 8) 640(11) 820(14) 1 000(17)	280( 4) 440( 6) 600( 8) 760(10) 1 000(13)
Pitch of mounting holes $F$	60	60	60	80
$E$ (1)	20	20	20	20
Standard range of $E$ (2)	incl.	6	8	9
	under	36	38	49
Maximum length (3)(4)	1 200 (1 600)	1 200 (1 960)	1 200 (1 960)	1 200 (1 960)

Note(1) : When specifying a butt-jointing interchangeable track rail (supplemental code "/T"), pay attention to the  $E$  dimension at the butt-jointing part.

(2) : Not applicable to the track rail with female threads for bellows (supplemental code "/J").

(3) : The  $E$  dimension for the rail with the maximum length is 1/2 of the  $F$  dimension.

(4) : Track rails with the maximum lengths shown in parentheses can also be manufactured. Consult **IKO** for further information.

Remark : The above table shows representative model numbers but is applicable to all models of the same size.

Flange type mounted from bottom  
**LWEC**  
**LWE**  
**LWEG**  
**LWEC...SL** (Stainless steel made)  
**LWE ...SL** (Stainless steel made)  
**LWEG...SL** (Stainless steel made)

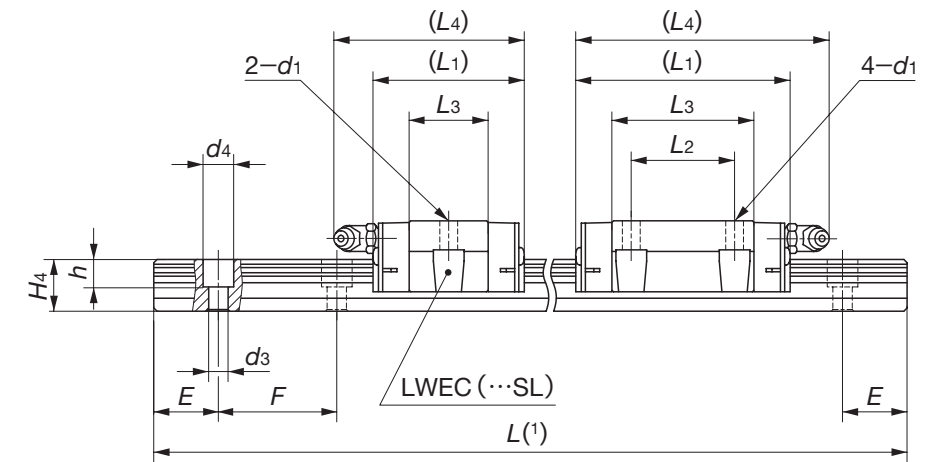
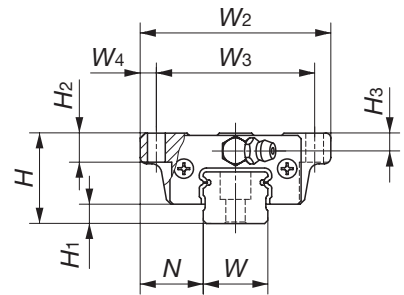

Model number	Interchangeable	Mass (Ref.)		Dimensions of assembly mm			Dimensions of slide unit mm							
		Slide unit kg	Track rail kg/m	H	H <sub>1</sub>	N	W <sub>2</sub>	W <sub>3</sub>	W <sub>4</sub>	L <sub>1</sub>	L <sub>2</sub>	L <sub>3</sub>	L <sub>4</sub>	d <sub>1</sub>
LWEC 15	☆	0.11	1.57	24	5.8	18.5	52	41	5.5	41	—	22.4	45	4.5
LWEC 15...SL	☆									57	26	38.4	61	
LWE 15	☆	0.18	2.28	28	6	19.5	59	49	5	70	36	51.1	74	5.5
LWE 15...SL	☆									66.5	32	44	79	
LWEG 15	☆	0.24	2.28	28	6	19.5	59	49	5	82	45	59.9	95	5.5
LWEG 15...SL	☆									66.5	32	44	79	
LWEC 20	☆	0.18	2.28	28	6	19.5	59	49	5	47	—	24.5	59	5.5
LWEC 20...SL	☆									66.5	32	44	79	
LWE 20	☆	0.30	2.28	28	6	19.5	59	49	5	66.5	32	44	79	5.5
LWE 20...SL	☆									66.5	32	44	79	
LWEG 20	☆	0.40	2.28	28	6	19.5	59	49	5	82	45	59.9	95	5.5
LWEG 20...SL	☆									66.5	32	44	79	

Note<sup>(1)</sup> : Track rail lengths are shown in Table 12.1 on page B-40 and Table 12.2 on page B-41.

(2) : The directions of basic dynamic load rating (C), basic static load rating (C<sub>0</sub>) and static moment rating (T<sub>0</sub>, T<sub>x</sub>, T<sub>y</sub>) are shown in the sketches below. The upper values in the T<sub>x</sub> and T<sub>y</sub> columns apply to one slide unit, and the lower values apply to two slide units in close contact.

Remark 1 : The mark ☆ indicates that interchangeable specification products are available.

2 : Track rail mounting bolts are not appended. Hexagon socket bolt of JIS B1176 strength division 12.9 or equivalent are recommended for high carbon steel model. The hexagon socket head bolts of JIS B1176 property division A2-70 or equivalent are recommended for stainless steel models. Recommended bolt sizes are shown in Table 6 on page B-37.

3 : For grease nipple specifications, see page 97.

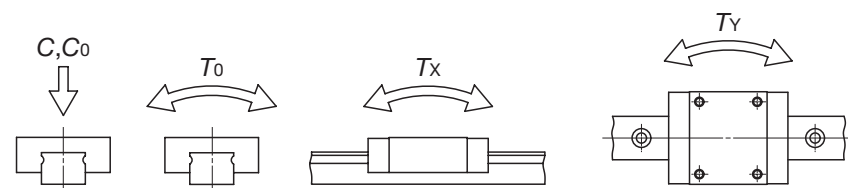

H <sub>2</sub>	H <sub>3</sub>	Dimensions of track rail mm								Basic dynamic load rating <sup>(2)</sup> C N	Basic static load rating <sup>(2)</sup> C <sub>0</sub> N	Static moment rating <sup>(2)</sup>		
		W	H <sub>4</sub>	d <sub>3</sub>	d <sub>4</sub>	h	E	F	T <sub>0</sub> N·m			T <sub>x</sub> N·m	T <sub>y</sub> N·m	
7	4.5	15	14.5	3.6	6.5	4.5	20	60		5 240	5 480	43.8	21.3 149	21.3 149
										7 640	9 390	75.1	57.6 333	57.6 333
										9 340	12 500	100	99.5 533	99.5 533
9	5.5	20	16	6	9.5	8.5	20	60		7 570	7 340	78.9	31.5 235	31.5 235
										11 600	13 400	145	95.6 561	95.6 561
										14 400	18 300	197	172 918	172 918

Example of identification number of assembled set (For details, see "Identification number and specification".)

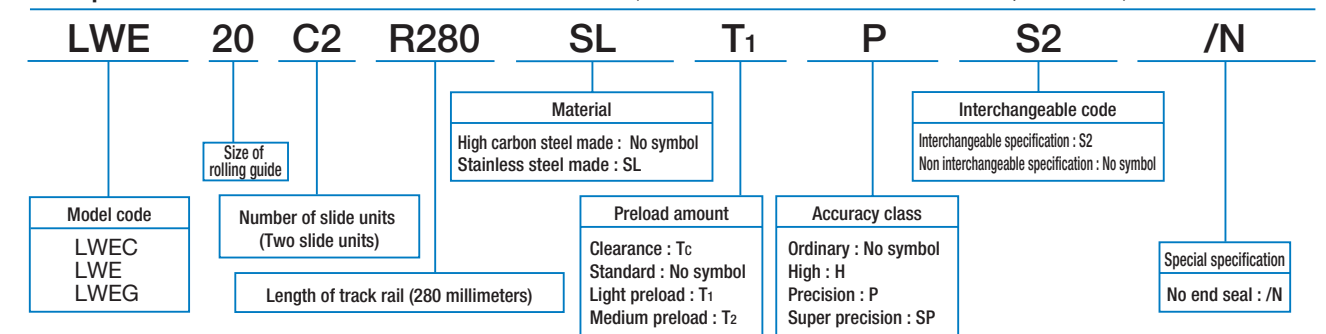

Flange type mounted from bottom  
**LWEC**  
**LWE**  
**LWEG**  
**LWEC...SL** (Stainless steel made)  
**LWE ...SL** (Stainless steel made)  
**LWEG...SL** (Stainless steel made)

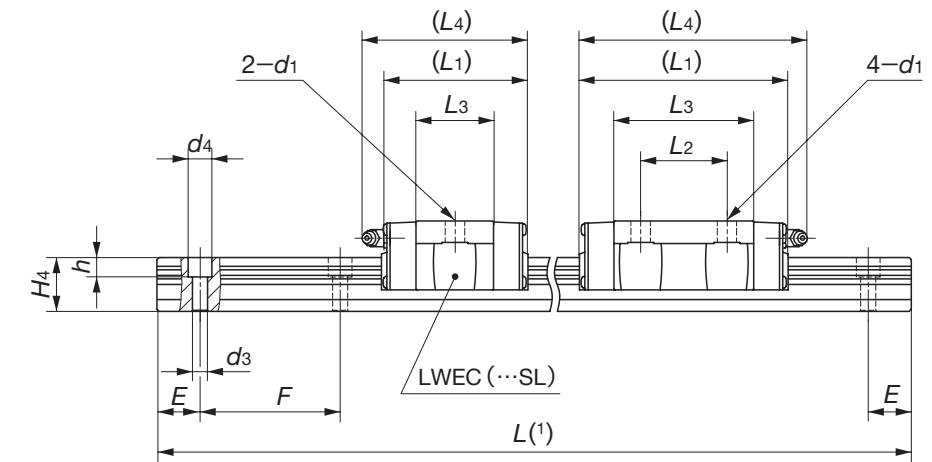
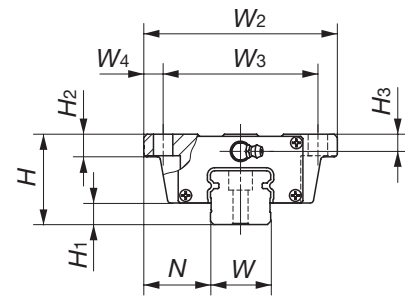

Model number	Interchangeable	Mass (Ref.)		Dimensions of assembly mm			Dimensions of slide unit mm							
		Slide unit kg	Track rail kg/m	H	H <sub>1</sub>	N	W <sub>2</sub>	W <sub>3</sub>	W <sub>4</sub>	L <sub>1</sub>	L <sub>2</sub>	L <sub>3</sub>	L <sub>4</sub>	d <sub>1</sub>
LWEC 25	☆	0.33	3.09	33	7	25	73	60	6.5	59	—	32	71	7
LWEC 25...SL	☆									83	35	56	95	
LWE 25	☆	0.55	3.09	33	7	25	73	60	6.5	102	50	75	114	7
LWE 25...SL	☆									83	35	56	95	
LWEG 25	☆	0.73	3.09	33	7	25	73	60	6.5	102	50	75	114	7
LWEG 25...SL	☆									83	35	56	95	
LWEC 30	☆	0.58	5.09	42	10	31	90	72	9	68	—	36	78	9
LWEC 30...SL	☆									97	40	64.8	107	
LWE 30	☆	0.99	5.09	42	10	31	90	72	9	128.5	60	96.5	139	9
LWE 30...SL	☆									97	40	64.8	107	
LWEG 30	☆	1.50	5.09	42	10	31	90	72	9	128.5	60	96.5	139	9
LWEG 30...SL	☆									97	40	64.8	107	
LWEC 35	☆	0.84	6.85	48	11	33	100	82	9	78	—	41.6	90	9
LWE 35	☆									111	50	74.6	123	
LWE 45	☆	2.46	11.2	60	14	37.5	120	100	10	125	60	81.4	136	11

Note(1) : Track rail lengths are shown in Table 12.1 on page B-40 and Table 12.2 on page B-41.

(2) : The directions of basic dynamic load rating (C), basic static load rating (C<sub>0</sub>) and static moment rating (T<sub>0</sub>, T<sub>x</sub>, T<sub>y</sub>) are shown in the sketches below. The upper values in the T<sub>x</sub> and T<sub>y</sub> columns apply to one slide unit, and the lower values apply to two slide units in close contact.

Remark 1 : The mark ☆ indicates that interchangeable specification products are available.

2 : Track rail mounting bolts are not appended. Hexagon socket bolt of JIS B1176 strength division 12.9 or equivalent are recommended for high carbon steel model. The hexagon socket head bolts of JIS B1176 property division A2-70 or equivalent are recommended for stainless steel models. Recommended bolt sizes are shown in Table 6 on page B-37.

3 : For grease nipple specifications, see page 97.

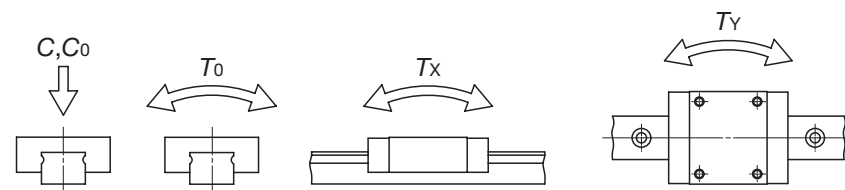

H <sub>2</sub>	H <sub>3</sub>	Dimensions of track rail mm							Basic dynamic load rating <sup>(2)</sup> C N	Basic static load rating <sup>(2)</sup> C <sub>0</sub> N	Static moment rating <sup>(2)</sup>		
		W	H <sub>4</sub>	d <sub>3</sub>	d <sub>4</sub>	h	E	F			T <sub>0</sub> N·m	T <sub>x</sub> N·m	T <sub>y</sub> N·m
10	6.5	23	19	7	11	9	20	60	12 400	12 300	153	71.8 480	71.8 480
									18 100	21 100	262	195 1 090	195 1 090
									22 200	28 200	349	336 1 740	336 1 740
10	8	28	25	7	11	9	20	80	20 600	18 800	287	129 855	129 855
									29 500	31 300	479	328 1 920	328 1 920
									39 200	47 000	718	704 3 670	704 3 670
13	10	34	28	9	14	12	20	80	29 900	26 800	412	176 1 190	162 1 100
									42 900	44 700	686	448 2 660	412 2 450
15	13	45	34	11	17.5	14	22.5	105	61 100	60 200	1 210	672 4 070	618 3 750

Example of identification number of assembled set (For details, see "Identification number and specification".)

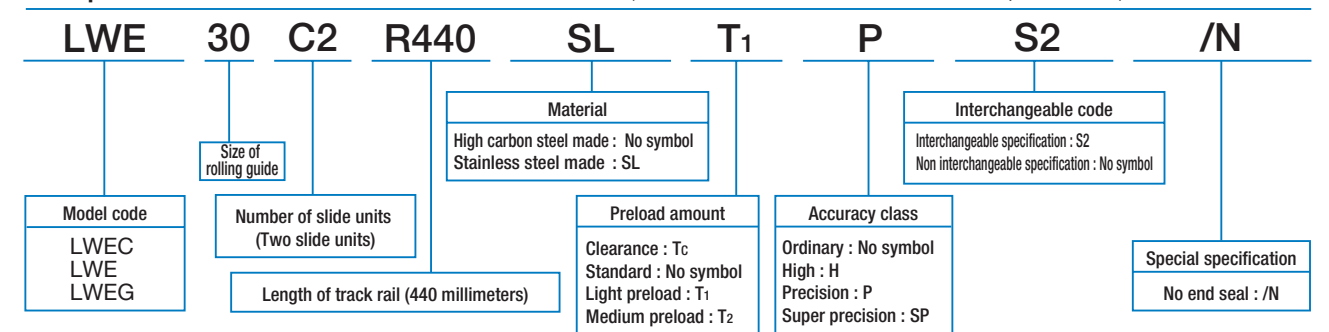



Flange type mounted from top  
**LWETC**  
**LWET**  
**LWETG**  
**LWETC...SL** (Stainless steel made)  
**LWET ...SL** (Stainless steel made)  
**LWETG...SL** (Stainless steel made)

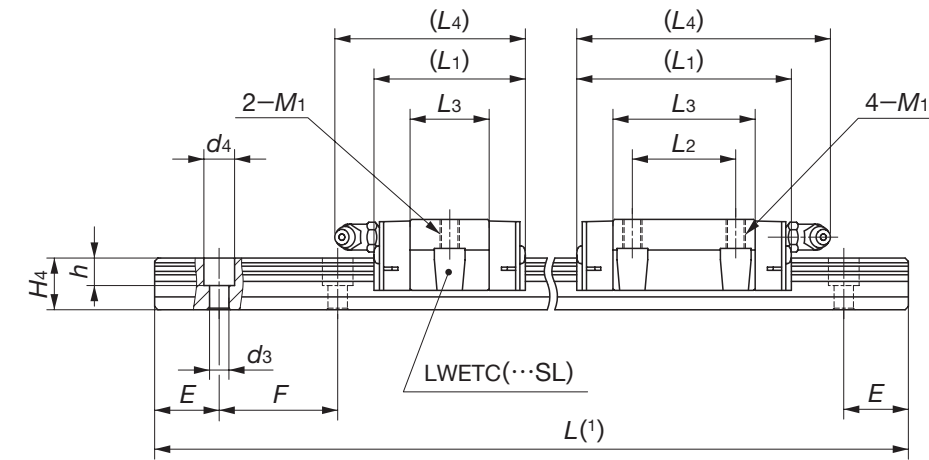
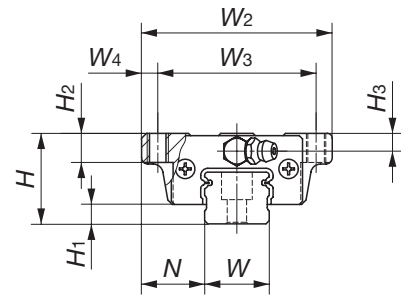

Model number	Interchangeable	Mass (Ref.)		Dimensions of assembly mm			Dimensions of slide unit mm							
		Slide unit kg	Track rail kg/m	H	H <sub>1</sub>	N	W <sub>2</sub>	W <sub>3</sub>	W <sub>4</sub>	L <sub>1</sub>	L <sub>2</sub>	L <sub>3</sub>	L <sub>4</sub>	M1
LWETC 15	☆	0.11	1.57	24	5.8	18.5	52	41	5.5	41	—	22.4	45	M 5
LWETC 15...SL	☆									57	26	38.4	61	
LWET 15	☆	0.18	2.28	28	6	19.5	59	49	5	70	36	51.1	74	
LWET 15...SL	☆									66.5	32	44	79	
LWETG 15	☆	0.24	2.28	28	6	19.5	59	49	5	82	45	59.9	95	
LWETG 15...SL	☆									82	45	59.9	95	
LWETC 20	☆	0.18	2.28	28	6	19.5	59	49	5	47	—	24.5	59	M 6
LWETC 20...SL	☆									66.5	32	44	79	
LWET 20	☆	0.30	2.28	28	6	19.5	59	49	5	70	36	51.1	74	
LWET 20...SL	☆									66.5	32	44	79	
LWETG 20	☆	0.40	2.28	28	6	19.5	59	49	5	82	45	59.9	95	
LWETG 20...SL	☆									82	45	59.9	95	

Note<sup>(1)</sup> : Track rail lengths are shown in Table 12.1 on page B-40 and Table 12.2 on page B-41.

<sup>(2)</sup> : The directions of basic dynamic load rating (C), basic static load rating (C<sub>0</sub>) and static moment rating (T<sub>0</sub>, T<sub>X</sub>, T<sub>Y</sub>) are shown in the sketches below. The upper values in the T<sub>X</sub> and T<sub>Y</sub> columns apply to one slide unit, and the lower values apply to two slide units in close contact.

Remark 1 : The mark ☆ indicates that interchangeable specification products are available.

2 : Track rail mounting bolts are not appended. Hexagon socket bolt of JIS B1176 strength division 12.9 or equivalent are recommended for high carbon steel model. The hexagon socket head bolts of JIS B1176 property division A2-70 or equivalent are recommended for stainless steel models. Recommended bolt sizes are shown in Table 6 on page B-37.

3 : For grease nipple specifications, see page 97.

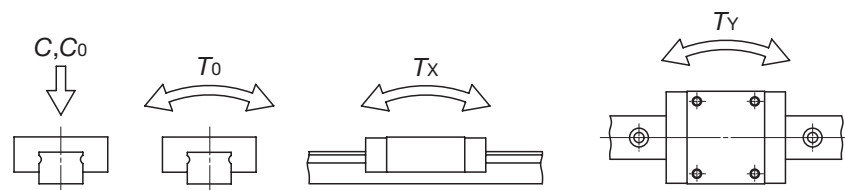

H <sub>2</sub>	H <sub>3</sub>	Dimensions of track rail mm								Basic dynamic load rating <sup>(2)</sup> C N	Basic static load rating <sup>(2)</sup> C <sub>0</sub> N	Static moment rating <sup>(2)</sup>		
		W	H <sub>4</sub>	d <sub>3</sub>	d <sub>4</sub>	h	E	F	T <sub>0</sub> N·m			T <sub>X</sub> N·m	T <sub>Y</sub> N·m	
7	4.5	15	14.5	3.6	6.5	4.5	20	60		5 240	5 480	43.8	21.3 149	21.3 149
										7 640	9 390	75.1	57.6 333	57.6 333
										9 340	12 500	100	99.5 533	99.5 533
9	5.5	20	16	6	9.5	8.5	20	60		7 570	7 340	78.9	31.5 235	31.5 235
										11 600	13 400	145	95.6 561	95.6 561
										14 400	18 300	197	172 918	172 918

Example of identification number of assembled set (For details, see "Identification number and specification".)

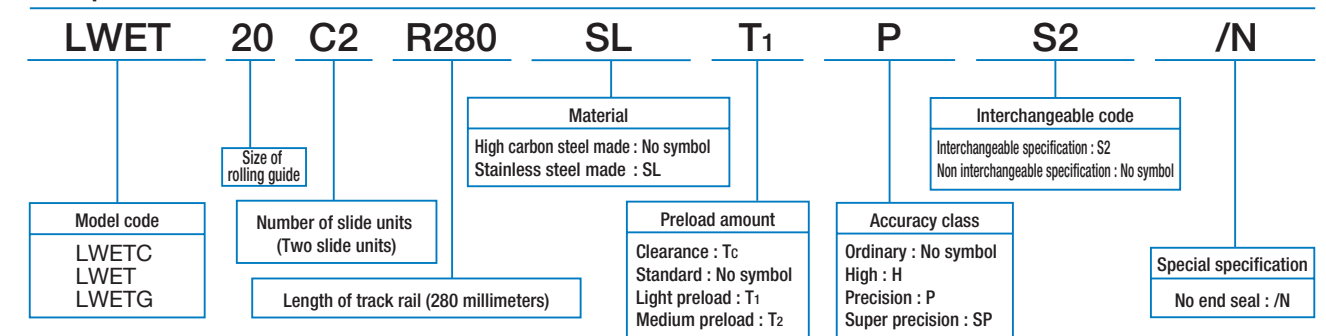

Flange type mounted from top  
**LWETC**  
**LWET**  
**LWETG**  
**LWETC ...SL** (Stainless steel made)  
**LWET ...SL** (Stainless steel made)  
**LWETG ...SL** (Stainless steel made)

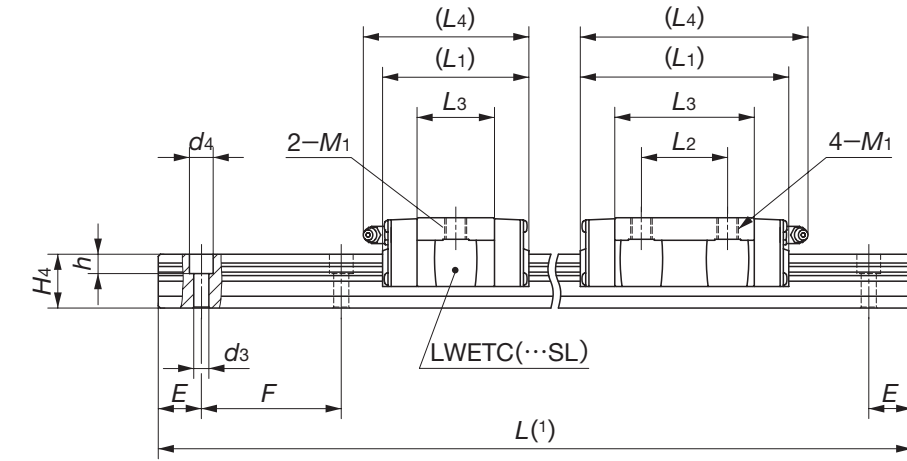
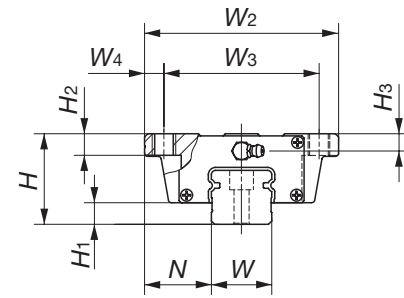

Model number	Interchangeable	Mass (Ref.)		Dimensions of assembly mm			Dimensions of slide unit mm							
		Slide unit kg	Track rail kg/m	H	H <sub>1</sub>	N	W <sub>2</sub>	W <sub>3</sub>	W <sub>4</sub>	L <sub>1</sub>	L <sub>2</sub>	L <sub>3</sub>	L <sub>4</sub>	M <sub>1</sub>
LWETC 25	☆	0.33	3.09	33	7	25	73	60	6.5	59	—	32	71	M 8
LWETC 25...SL	☆									83	35	56	95	
LWET 25	☆	0.55	3.09	33	7	25	73	60	6.5	102	50	75	114	M 8
LWET 25...SL	☆									83	35	56	95	
LWETG 25	☆	0.73	3.09	33	7	25	73	60	6.5	102	50	75	114	M 8
LWETG 25...SL	☆									83	35	56	95	
LWETC 30	☆	0.58	5.09	42	10	31	90	72	9	68	—	36	78	M 10
LWETC 30...SL	☆									97	40	64.8	107	
LWET 30	☆	0.99	5.09	42	10	31	90	72	9	128.5	60	96.5	139	M 10
LWET 30...SL	☆									97	40	64.8	107	
LWETG 30	☆	1.50	5.09	42	10	31	90	72	9	128.5	60	96.5	139	M 10
LWETG 30...SL	☆									97	40	64.8	107	
LWETC 35	☆	0.84	6.85	48	11	33	100	82	9	78	—	41.6	90	M 10
LWET 35	☆									111	50	74.6	123	
LWET 45	☆	2.46	11.2	60	14	37.5	120	100	10	125	60	81.4	136	M 12

Note(1) : Track rail lengths are shown in Table 12.1 on page B-40 and Table 12.2 on page B-41.

(2) : The directions of basic dynamic load rating (C), basic static load rating (C<sub>0</sub>) and static moment rating (T<sub>0</sub>, T<sub>x</sub>, T<sub>y</sub>) are shown in the sketches below. The upper values in the T<sub>x</sub> and T<sub>y</sub> columns apply to one slide unit, and the lower values apply to two slide units in close contact.

Remark 1 : The mark ☆ indicates that interchangeable specification products are available.

2 : Track rail mounting bolts are not appended. Hexagon socket bolt of JIS B1176 strength division 12.9 or equivalent are recommended for high carbon steel model. The hexagon socket head bolts of JIS B1176 property steel model A2-70 or equivalent are recommended for stainless steel models. Recommended bolt sizes are shown in Table 6 on page B-37.

3 : For grease nipple specifications, see page 97.

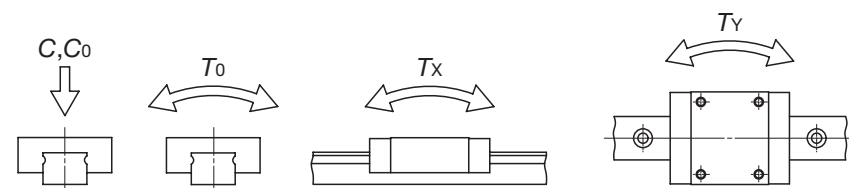

H <sub>2</sub>	H <sub>3</sub>	Dimensions of track rail mm							Basic dynamic load rating <sup>(2)</sup> C N	Basic static load rating <sup>(2)</sup> C <sub>0</sub> N	Static moment rating <sup>(2)</sup>		
		W	H <sub>4</sub>	d <sub>3</sub>	d <sub>4</sub>	h	E	F			T <sub>0</sub> N·m	T <sub>x</sub> N·m	T <sub>y</sub> N·m
10	6.5	23	19	7	11	9	20	60	12 400	12 300	153	71.8 480	71.8 480
									18 100	21 100	262	195 1 090	195 1 090
									22 200	28 200	349	336 1 740	336 1 740
10	8	28	25	7	11	9	20	80	20 600	18 800	287	129 855	129 855
									29 500	31 300	479	328 1 920	328 1 920
									39 200	47 000	718	704 3 670	704 3 670
13	10	34	28	9	14	12	20	80	29 900	26 800	412	176 1 190	162 1 110
									42 900	44 700	686	448 2 660	412 2 450
15	13	45	34	11	17.5	14	22.5	105	61 100	60 200	1 210	672 4 070	618 3 750

Example of identification number of assembled set (For details, see "Identification number and specification".)

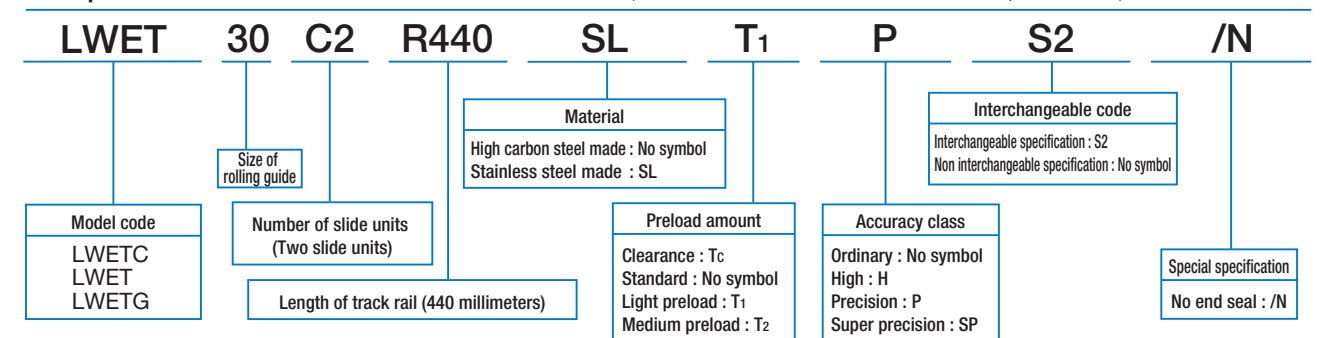

Block type mounted from top  
**LWESC**  
**LWES**  
**LWESG**  
**LWESC ...SL** (Stainless steel made)  
**LWES ...SL** (Stainless steel made)  
**LWESG ...SL** (Stainless steel made)

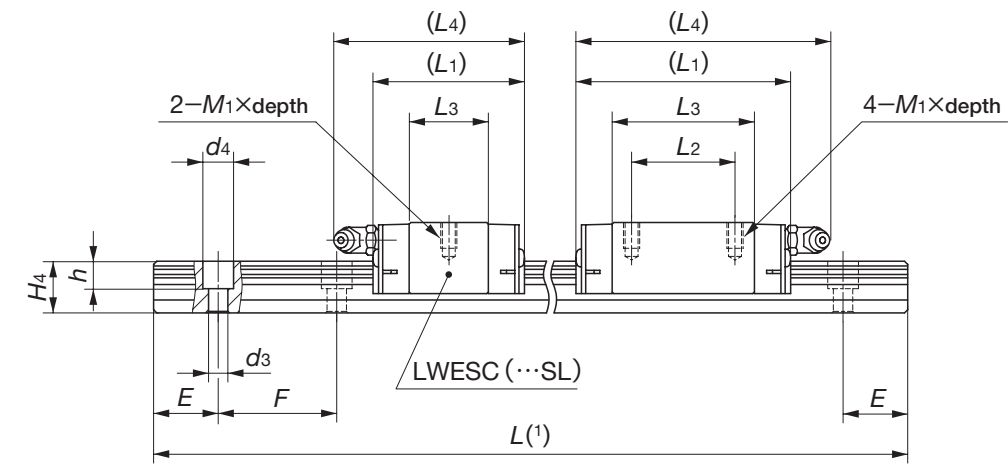
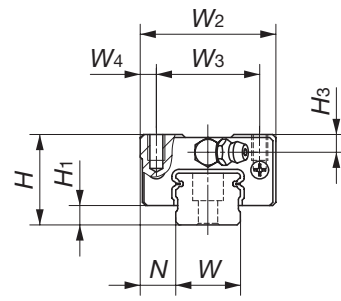

Model number	Interchangeable	Mass (Ref.)		Dimensions of assembly mm			Dimensions of slide unit mm						
		Slide unit kg	Track rail kg/m	H	H <sub>1</sub>	N	W <sub>2</sub>	W <sub>3</sub>	W <sub>4</sub>	L <sub>1</sub>	L <sub>2</sub>	L <sub>3</sub>	L <sub>4</sub>
LWESC 15	☆	0.09	1.57	24	5.8	9.5	34	26	4	41	—	22.4	45
LWESC 15...SL	☆									57	26	38.4	61
LWES 15	☆	0.14	1.57	24	5.8	9.5	34	26	4	70	36	51.1	74
LWES 15...SL	☆									70	36	51.1	74
LWESG 15	☆	0.18	1.57	24	5.8	9.5	34	26	4	47	—	24.5	59
LWESG 15...SL	☆									47	—	24.5	59
LWESC 20	☆	0.15	2.28	28	6	11	42	32	5	66.5	32	44	79
LWESC 20...SL	☆									66.5	32	44	79
LWES 20	☆	0.25	2.28	28	6	11	42	32	5	82	45	59.9	95
LWES 20...SL	☆									82	45	59.9	95
LWESG 20	☆	0.33	2.28	28	6	11	42	32	5	82	45	59.9	95
LWESG 20...SL	☆									82	45	59.9	95

Note<sup>(1)</sup> : Track rail lengths are shown in Table 12.1 on page B-40 and Table 12.2 on page B-41.

(2) : The directions of basic dynamic load rating (C), basic static load rating (C<sub>0</sub>) and static moment rating (T<sub>0</sub>, T<sub>x</sub>, T<sub>y</sub>) are shown in the sketches below. The upper values in the T<sub>x</sub> and T<sub>y</sub> columns apply to one slide unit, and the lower values apply to two slide units in close contact.

Remark 1 : The mark ☆ indicates that interchangeable specification products are available.

2 : Track rail mounting bolts are not appended. Hexagon socket bolt of JIS B1176 strength division 12.9 or equivalent are recommended for high carbon steel model. The hexagon socket head bolts of JIS B1176 property division A2-70 or equivalent are recommended for stainless steel models. Recommended bolt sizes are shown in Table 6 on page B-37.

3 : For grease nipple specifications, see page 97.

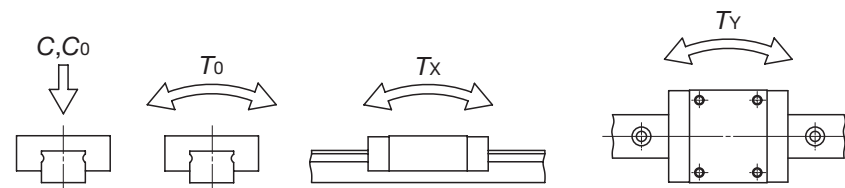

M <sub>1</sub> ×depth	H <sub>3</sub>	Dimensions of track rail mm							Basic dynamic load rating <sup>(2)</sup> C N	Basic static load rating <sup>(2)</sup> C <sub>0</sub> N	Static moment rating <sup>(2)</sup>		
		W	H <sub>4</sub>	d <sub>3</sub>	d <sub>4</sub>	h	E	F			T <sub>0</sub> N·m	T <sub>x</sub> N·m	T <sub>y</sub> N·m
M4×7	4.5	15	14.5	3.6	6.5	4.5	20	60	5 240	5 480	43.8	21.3 149	21.3 149
									7 640	9 390	75.1	57.6 333	57.6 333
									9 340	12 500	100	99.5 533	99.5 533
M5×8	5.5	20	16	6	9.5	8.5	20	60	7 570	7 340	78.9	31.5 235	31.5 235
									11 600	13 400	145	95.6 561	95.6 561
									14 400	18 300	197	172 918	172 918

Example of identification number of assembled set (For details, see "Identification number and specification".)

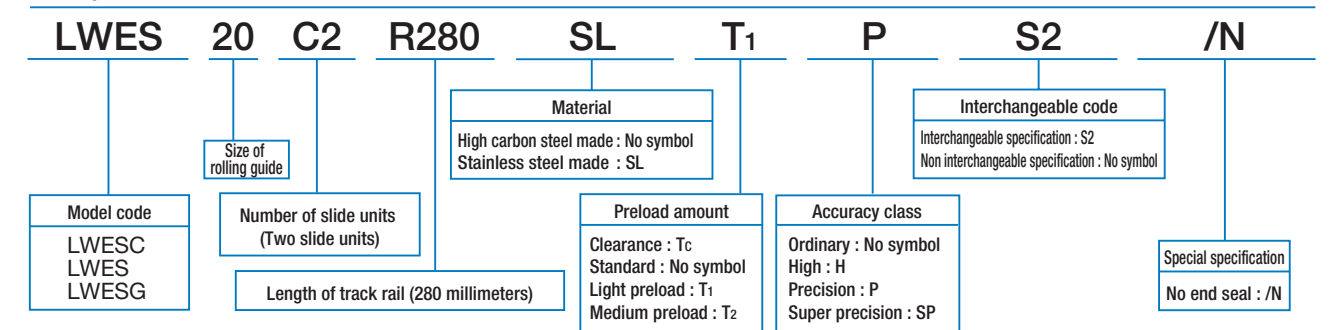

Block type mounted from top

- LWESC
- LWES
- LWESG
- LWESC ...SL (Stainless steel made)
- LWES ...SL (Stainless steel made)
- LWESG ...SL (Stainless steel made)

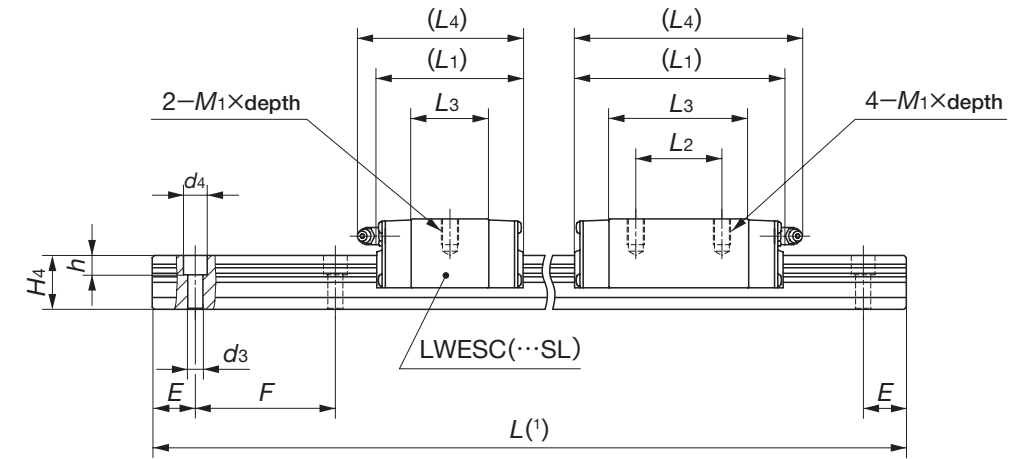
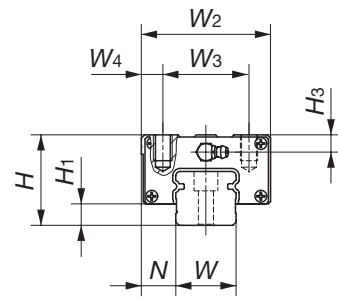

Model number	Interchangeable	Mass (Ref.)		Dimensions of assembly mm			Dimensions of slide unit mm						
		Slide unit kg	Track rail kg/m	H	H <sub>1</sub>	N	W <sub>2</sub>	W <sub>3</sub>	W <sub>4</sub>	L <sub>1</sub>	L <sub>2</sub>	L <sub>3</sub>	L <sub>4</sub>
LWESC 25	☆	0.26	3.09	33	7	12.5	48	35	6.5	59	—	32	71
LWESC 25...SL	☆									83	35	56	95
LWES 25	☆	0.42	3.09	33	7	12.5	48	35	6.5	102	50	75	114
LWES 25...SL	☆									128.5	60	96.5	139
LWESG 25	☆	0.55	3.09	33	7	12.5	48	35	6.5	68	—	36	78
LWESG 25...SL	☆									97	40	64.8	107
LWESC 30	☆	0.46	5.09	42	10	16	60	40	10	78	—	41.6	90
LWESC 30...SL	☆									111	50	74.6	123
LWES 30	☆	0.78	5.09	42	10	16	60	40	10	128.5	60	96.5	139
LWES 30...SL	☆									128.5	60	96.5	139
LWESG 30	☆	1.13	5.09	42	10	16	60	40	10	78	—	41.6	90
LWESG 30...SL	☆									111	50	74.6	123
LWESC 35	☆	0.67	6.85	48	11	18	70	50	10	78	—	41.6	90
LWES 35	☆									111	50	74.6	123
LWES 45	☆	2.05	11.2	60	14	20.5	86	60	13	125	60	81.4	136

Note(1) : Track rail lengths are shown in Table 12.1 on page B-40 and Table 12.2 on page B-41.

(2) : The directions of basic dynamic load rating (C), basic static load rating (C<sub>0</sub>) and static moment rating (T<sub>0</sub>, T<sub>x</sub>, T<sub>y</sub>) are shown in the sketches below. The upper values in the T<sub>x</sub> and T<sub>y</sub> columns apply to one slide unit, and the lower values apply to two slide units in close contact.

Remark 1 : The mark ☆ indicates that interchangeable specification products are available.

2 : Track rail mounting bolts are not appended. Hexagon socket bolt of JIS B1176 strength division 12.9 or equivalent are recommended for high carbon steel model. The hexagon socket head bolts of JIS B1176 property division A2-70 or equivalent are recommended for stainless steel models. Recommended bolt sizes are shown in Table 6 on page B-37.

3 : For grease nipple specifications, see page 97.

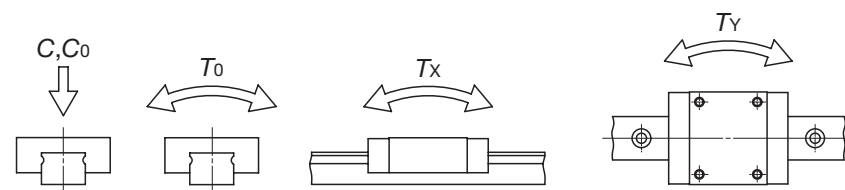

M <sub>1</sub> × depth	H <sub>3</sub>	Dimensions of track rail mm							Basic dynamic load rating <sup>(2)</sup> C N	Basic static load rating <sup>(2)</sup> C <sub>0</sub> N	Static moment rating <sup>(2)</sup>		
		W	H <sub>4</sub>	d <sub>3</sub>	d <sub>4</sub>	h	E	F			T <sub>0</sub> N·m	T <sub>x</sub> N·m	T <sub>y</sub> N·m
M 6 × 9	6.5	23	19	7	11	9	20	60	12 400	12 300	153	71.8 480	71.8 480
									18 100	21 100	262	195 1 090	195 1 090
									22 200	28 200	349	336 1 740	336 1 740
M 8 × 12	8	28	25	7	11	9	20	80	20 600	18 800	287	129 855	129 855
									29 500	31 300	479	328 1 920	328 1 920
									39 200	47 000	718	704 3 670	704 3 670
M 8 × 12	10	34	28	9	14	12	20	80	29 900	26 800	412	176 1 190	162 1 100
									42 900	44 700	686	448 2 660	412 2 450
M10 × 15	13	45	34	11	17.5	14	22.5	105	61 100	60 200	1 210	672 4 070	618 3 750

Example of identification number of assembled set (For details, see "Identification number and specification".)

