

Vacuum Environment Linear Roller Way Super X



Linear Roller Way enables to be used in vacuum environment is debut!

New Vacuum Environment Linear Roller Way Super X is a series of roller-type linear motion rolling guides that combine a corrosion-resistant stainless-steel casing with resin parts, such as a super-engineering plastic (PEEK resin) end plate, to solve this problem, thereby achieving excellent low out-gassing characteristics. It consistently exhibits the superb characteristics of a roller-type linear motion rolling guides, such as high load-carrying capacity, high rigidity and smooth and low-friction running performance, in a vacuum environment.

Structure of Vacuum Environment Linear Roller Way Super X

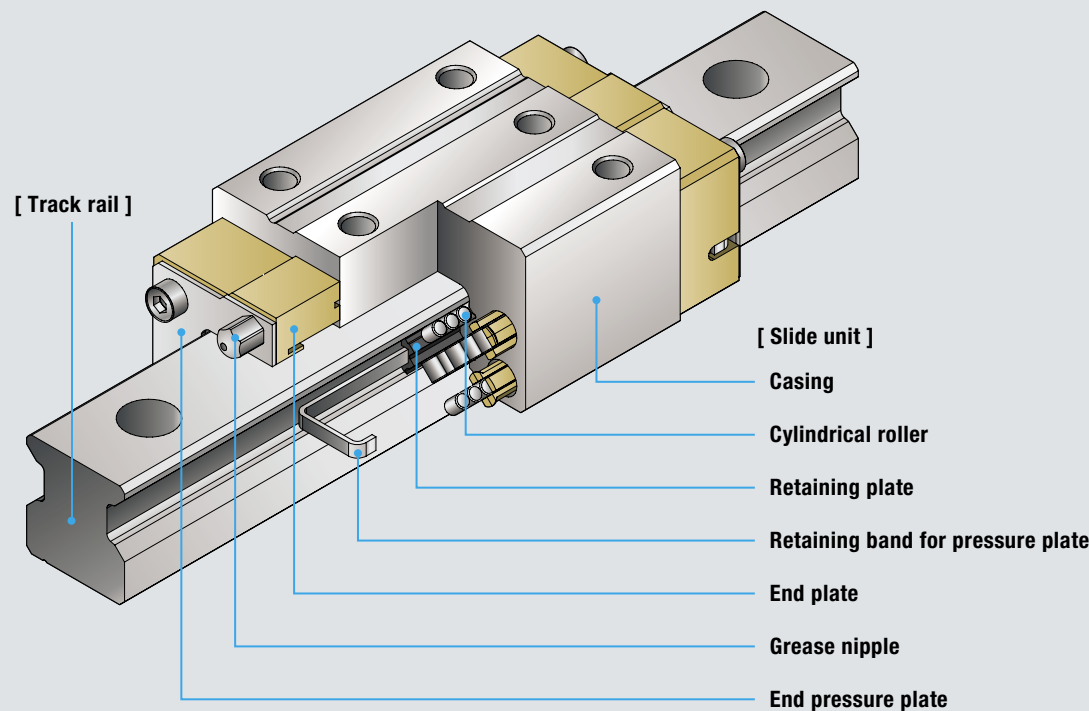

Features

1 Usable from low to high-vacuum regions! (vacuum 10^{-3} [Pa])

2 Excellent low outgassing characteristics!

3 Baking temperatures up to 200°C!

Temperature in a static state.
At baking temperatures above 150 degree C, multiply the basic load rating by a temperature coefficient.

4 Superb corrosion resistance!

Corrosion-resistant stainless steel is used on all steel parts.

Lubricant selection

Fluorine-based grease is recommended. Please pay attention to the relation also between vapor pressure and temperature of fluorine-based as shown in following graph when selection of grease. For detail information, please refer to catalog of grease manufacture.

Relationship example between vapor pressure and temperature of fluorine-based grease

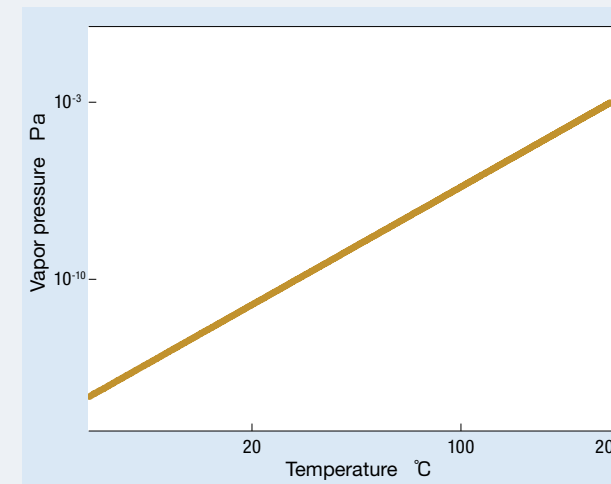

Typical brands of fluorine greases

| Name of lubricant | Manufacturer |
|----------------------|-------------------------|
| BARRIERTA SUPER IS/V | NOK Kluber Co., Ltd. |
| DEMNUM™ GREASE L-200 | Daikin Industries, Ltd. |
| FLUOTRIBO VAC | KYODO YUSHI CO., LTD. |
| FOMBLIN® VAC3 | Solvay Solexis |
| KRYTOX® LVP | DuPont |

Remarks 1. FOMBLIN® is a registered trademark of Solvay Solexis.
2. KRYTOX® is a registered trademark of DuPont.

Specifications

Please contact to IKO for a choice of optimal specifications customised for your using conditions.

| Customization | |
|-----------------|---------------------------|
| Series | Linear Roller Way Super X |
| Applicable type | LRXD20...SL |

| Material of main component | |
|----------------------------|--|
| Casing | Martensitic stainless steel |
| Track rail | Martensitic stainless steel |
| Cylindrical roller | Martensitic stainless steel |
| End plate | Super-engineering plastic (PEEK resin) |